

Beekeeping for Honey Production in Sri Lanka

Management of Asiatic Hive Honeybee *Apis cerana*
in its Natural Tropical Monsoonal Environment



R. W. K. Punchihewa

A Trace from the Honey Hunting Practiced in Sri Lanka in the Past:
How it was taught and the appliances used.



"One thing is taught the iads systematically that is method of collecting honey from the combs of the rock bee (Bambara Bees). Whenever the caves are conveniently situated a ladder of creepers is suspended from a tree in the jungle above and hangs over the end of the face of rock which forms the cave..... and the elder men showed clearly that this was a game which they encouraged. A lad of about thirteen collected some green leaves and tied them together with creeper, then taking an arrow, a toy *masliya*, and a broken gourd tied with creeper, which hung over his arm, for a *maludema*, he set fire to the leaves and climbed the ladder. While lowering the smoker and letting the smoke blow into the crevice in the rock where the comb was supposed to be, he pretended to cut round its sides with an arrow and thrust at it with his *masliya* from which he transferred the honey into the gourd. As he descended from the ladder he beat his chest and sides as though driving off the bees, and directly he reached the ground rushed into the jungle to escape from them, all the smaller children imitating him with great glee. Obviously this was a well-known and favourite game, for even the elders took part in it, throwing their cloths over their heads and running into the jungle". - Family Life of Veddas, from Seligmann & Seligmann (1911), THE VEDDAS, pages 91-92.



x $\frac{1}{40}$

The smoker or the **Hula** used in smoking



x $\frac{1}{60}$

The toy **Masliya**, or the toy honey comb collector



x $\frac{1}{60}$

The **Masliya** or **Matha** used in removal and collection of honeycombs in honey hunting.

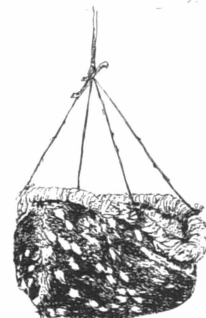

x $\frac{1}{15}$

Honey comb collections vessel or the **Maludema** or **Hangotuwa** made out of deer skin.

Beekeeping for Honey Production in Sri Lanka

**Management of Asiatic Hive Honeybee *Apis cerana*
in its Natural Tropical Monsoonal Environment**

By the same Author

SRI LANKAWE MEE PENI NISHPADANAYA SANDAHA BINGU PALANAYA (1994)

ශ්‍රී ලංකාවේ මි පැණි තිඡ්පාදනය සඳහා බිඟු පාලනය

ISBN 955 - 9282 - 00 - X

Beekeeping for Honey Production in Sri Lanka

**Management of Asiatic Hive Honeybee *Apis cerana*
in its Natural Tropical Monsoonal Environment**

R.W.K. Punchihewa

B.Sc.Ag.(Peradeniya/Sri Lanka); M.Sc.(Guelph/Canada); Dr.Phil.Nat.(Frankfurt am Main/Germany)
Sri Lanka Department of Agriculture,

Prepared for Sri Lanka - Canada Honey Production Development Programme

Sponsored and Published by the

Sri Lanka Department of Agriculture,
Peradeniya, Sri Lanka.

in collaboration with

Canadian International Development Agency,
Hull, Quebec, Canada.

First Edition: 1994

ISBN 955 - 9282 - 01 - 8

All Rights Reserved.

No part of this book may be reprinted, or reproduced or utilized in any form or by any electronic, mechanical or other means, now known or hereafter invented, including photocopying and recording, or any information storage and retrieval system, without permission in writing from the copyright holder.

- Cover Design: by Mr. Nandasiri Baddegama.
- The illustrations in the innerside of the front cover were done by using the information and adapting the illustrations given in Seligmann & Seligmann (1911)
and
The illustration of Honey Hunting on page xii, was redrawn by adapting the information and the illustration of Spittel (1945)
by
Mr. Nandasiri Baddegama.
- The Map on Figure 10.5 by Mr. M.T.N.Fernando.

In the preparation of the following diagrams the undermentioned publications were used.

- For Figures 1.13, 1.14 and 1.15:
 - Dance Language and Orientation of Bees by Karl von Frisch, © 1967, 1993 Harvard University Press, Cambridge, Massachusetts, USA (Permit Reference Number 941015).
 - The Hive and the Honey Bee-Edited by Dadant & Sons © 1946, 1949, 1963, 1975 Dadant & Sons, Inc., Hamilton, Illionis, USA (open permit with due acknowledgment).
- For Figures 1.18 and 1.19:
 - The Social Behaviour of Bees by Charles D. Michener © 1974 Harvard University Press, Cambridge, Massachusetts, USA (Permit Reference Number 941016) and with the kind permission of Prof. Charles D. Michener, The University of Kansas, Lawrence, Kansas, USA.
 - The Hive and the Honey Bee-Edited by Dadant & Sons © 1946, 1949, 1963, 1975 Dadant & Sons, Inc., Hamilton, Illionis, USA (open permit with due acknowledgment).
 - Pheromones of Social Bees by John B. Free © 1987 John B. Free, Chapman and Hall Ltd., London, UK, with the kind permission of Prof. John B. Free, University of Wales at Cardiff, UK.
- Figures 1.8 and 4.2 were redrawn by using the diagrams given in:
 - Jordan, R (1951) Bienenkundliche Lehrtafeln, Bundeslehr-und Versuchsanstalt für Bienenkunde, Wein, Öesterreich (Vienna, Austria). with appropriate modifications to suit the Sri Lankan hive honeybee.

CONTENTS

Dedication	v
Preface	vi
Foreword	vii
Acknowledgement	ix
Of Honeybees and Honey Hunting	xii
Introduction	xiv
Honeybees of Asia:	
A Prologue by Prof. Nikolaus Koeniger and Dr. (Mrs.) Gudrun Koeniger	xx
1. Bees and Beekeeping	1
1.1. Bees	1
1.2. Honeybees	1
1.3. Rearing Bees	4
1.4. A Honeybee Colony	8
1.4.1. The Colony Life	8
1.4.2. Communication in Honeybees	13
1.4.2.1. Chemical Communication Signals	13
1.4.2.2. Physical Communication Signals	14
1.4.2.3. The Nest Architecture of Honeybees Determined by the Physical Communication Ability	25
1.4.2.4. Energy Conservation by Means of the Bee Dance	26
1.4.2.5. Bee Hissing: another communication method in Mee Bees	26
1.4.3. Stages of Life and Activities of Three Types of Colony Members	27
1.4.4. Division of Labour and Functional Specialization Among Female Members of the Colony	29
1.5. Some Distinctive Characteristics of Honeybees	31
1.5.1. Adaptations to Live on Flowers: pollen collection and storage	32
1.5.2. Adaptations to Live on Flowers: nectar collection and honey making	35
1.5.3. Some Features Important in Beekeeping	35
- 1.5.3.1. Stinging and Smoking	35
1.5.3.2. Memory, Learning Ability and Changing Hive Position	36
2. Principles of Beekeeping	41
2.1. The Essential Prerequisites	41
2.2. Environmental Conditions	42
2.2.1. Climatic Conditions	42
2.2.2. Bee Forage: nectar and pollen sources	43
2.3. Foraging Range: an important limiting factor	50
2.4. The Competition for Food Among Honeybees and their Migratory Habits	53

3. Animal Keeping (Animal Husbandry) and Beekeeping	55
4. Hive: An Important Device in Managing Honeybees	57
4.1. Movable Comb Hive	57
4.2. Some Vital Measurements for Hive Designing	59
4.2.1. Bee-Space	60
4.2.2. Comb Thickness	60
4.2.3. Comb Spacing	60
4.3. Hive Design Criterion for <i>Apis cerana indica</i> in Sri Lanka	62
4.3.1. Preliminary Considerations	62
4.3.2. Design Considerations	62
4.4. Suitable Hives from a Historical Perspective	62
4.5. Features of a Suitable Hive for the Present Day	64
4.5.1. Floor-board	64
4.5.2. Brood Chamber	65
4.5.3. Top-bars vs. Frames for the Brood Chamber: a comparison	65
4.5.4. Dummy-Board or Movable Wall	70
4.5.5. Honey Chamber or Honey-Supers or Supers	70
4.5.6. Crown Board or the Inner Cover	71
4.5.7. Roof	71
4.5.8. Entrance Guard or Queen Guard	71
4.5.9. Other Beekeeping Appliances and Auxiliary Tools	74
4.6. Suitable Timber for Hive Construction	74
4.7. Hive Manipulation	75
4.8. Comb Breakage and Repair	75
4.9. Auxiliary Appliances and Techniques	78
5. Growth of a Bee Population and the Management of a Colony	81
5.1. Natural Growth in a Colony	81
5.2. Old Combs: An Important Resource in the Management of <i>Apis cerana</i> in Sri Lanka.	82
5.3. Population Management	86
5.3.1. A Prolific Queen with a Good Egg Laying Ability	86
5.3.2. Provision of Sufficient Space	94
5.3.2.1. Space Requirement Depending on the Growth	94
5.3.2.2. Space Requirement Depending on Environmental Conditions	95
5.3.3. Population Management During the Growth Phase	95
5.3.3.1. Initiating Growth	98
5.3.3.2. Continuation of Growth to Six Brood Combs	102
5.3.3.3. Expanding the Nest to the First Super	102
5.3.3.4. Expanding the Brood Nest to Seven Combs	102
5.3.3.5. Expanding the Nest to the Second Super and Completion of Two Supers With Combs	102
5.3.3.6. Completion of Brood Chamber	106

5.3.3.7. Rapid Growth Phase Prior to the Honey-flow	106
5.3.3.8. Optimum Size of the Colony	106
5.3.3.9. Uniting Two Colonies to Increase Colony Population (and Honey Yield)	113
5.3.3.10. Judging the Growth or the Decline of the Colony Population	114
5.3.4. Population Management During the Honey-flow Period	114
5.3.5. Population Management During the Dearth Period	115
5.4. Preservation and Storage of Empty Honey Combs for the Next Season	116
5.5. Summary of the Management Practices	118
6. Management of Swarming and Production of New Colonies	121
6.1. Swarming	121
6.2. Predicting the Preparation for Swarming	124
6.3. Management of Swarming and Production of New Colonies	129
6.4. Who Should Lead the Honey Production Colonies, New Queens or Old Queens ?	141
6.5. Age of the Queen in Productive Colonies	142
6.6. Laying Workers: a problem in new colony production	142
6.7. Queen Laying in Honey Supers: another problem that can take place during swarming season	145
6.8. Collection of Swarms and Natural Colonies	145
6.8.1. Collection of Swarms	145
6.8.2. Collection of Natural Colonies	147
7. Supplementary Feeding for the Prevention of Absconding and Pest Incidence	149
7.1. Absconding	149
7.2. Pollen Incoming Rate	149
7.3. Preparation for Absconding	154
7.4. Prevention of Absconding	155
7.4.1. The Queen Guard Method	155
7.4.2. The Queen Cage Method	157
7.5. Defence Behaviour	157
7.6. Supplementary Feeding	162
7.7. Other Aspects of Supplementary Feeding	164
7.7.1. Feeding Sugar	164
7.7.2. Feeding Pollen Substitute	164
7.8. Other Animals Associated with the Nest of Mee Bees and their Pest Status	165
8. Smoking	170
8.1. Smoker	170
8.2. Smoking	170
9. Honey Extraction	174
9.1. A Honey-Flow	174
9.2. Honey Storage in a Nest of Honeybees	174

9.3. Removal of Honey	175
9.4. Honey Extractor	178
10. Economics of Beekeeping	181
10.1. How to Start Beekeeping with Mee Bees	181
10.2. How Much Honey to be Produced ?	182
10.3. How Much Honey Do We Need and For What Purpose ?	188
10.4. Apiary Layout	188
10.5. The Environmental and Socio-Economic Basis of Beekeeping	189
10.6. The Future of Beekeeping: an epilogue	193
10.6.1. Crop Pollination Requirements	193
10.6.2. Factor Analysis of Honey Production	196
10.6.3. The Need for and the Problems of Breeding Honeybees	197
10.6.4. Action Plan for the Improvement of the Indigenous Mee Bee or the Local Hive Honeybee	202
10.7. The Natural Resources We Inherit for the Development of Apiculture	207
11. Glossary	209
12. References	215
13. Index	221

This book contains
116 Colour Photographs, 42 Diagrams and a Map

FOREWORD

An inviting mood for reading this book is convincingly created in the opening "Introduction" of a few brief paragraphs by the author; and the underlying rationale for this book is essentially captured in the quotations from Aristotle and Francis Bacon.

For the environmentalist, the starting point for his or her interest begins with the closing section of the last chapter of the book, namely Chapter 10, Section 10.7, page 207 which reads as follows.

"Even though historically we do not seem to possess a tradition of bee-culture, honey had been an important and a common ingredient in our traditional medical practice. Attempted honey production may not have been a necessity due to the existence of large areas of forest which supplied sufficient quantities of this commodity. Even at present honey hunting still takes place near forested areas.

These forests also have not only a productive strain of Mee bees but a large resource of other types of bees that could be used in crop pollination. Therefore, our forests contain an invaluable resource and a reserve of bee fauna that can contribute to honey production and crop production. As such we have to protect and preserve the forests, the natural birth place of all our bee fauna for posterity and prosperity."

The great love and the sympathy that the author has for the Mee bee is so well reflected in both the contents as well as in manner of presentation of the subject matter. Equally important is the fact that the author has discussed and presented the Mee bee in its total environmental setting, which serves to clearly bring out its vital interactions with the relevant components of the environment.

The structure and organization of the respective chapters follow a very logical sequence which, in turn, help to sustain the reader's interest throughout the ten chapters of this book. Similarly, the well selected choice of colour photographs, together with the diagrams and tables, complement and lend excellent support to the printed text - the hallmark of a truly creative scientific effort.

A special feature of this book is the approach adopted by the author wherein the subject matter has been presented and discussed from the standpoint of the generally well known and easily understood first principle of the natural sciences. This brings this publication within the reach of understanding and interest of both the student and the professional alike.

That very distinguished biological scientist of this century, the late Professor JBS Haldane FRS, when addressing the Ceylon Association for the Advancement of Science (now SLAAS) as its chief guest in 1960, observed that Sri Lanka offered the best prospects for charting a new direction in the biological sciences by proper observation of animal behaviour in contrast to the Western approach of cutting-up and dissection of animals. This, he reasoned should be feasible on account of the country's dominant Buddhistic culture which shows a sympathy and

tolerance towards animals. Dr. Punchihewa has, more than 33 years later, amply vindicated Prof. Haldane's vision in this regard.

A very valuable innovation in his book is the inclusion of extracts from selective sources of past publications and writings such as those of Seligmanns, Spittel, Dep etc., some better known than others. This helps to provide the reader a historical link with the past understandings of our oral traditions of knowledge in this field, none or little of which has been customarily committed to writing.

While the author has not failed to pay tributes to the pioneers of his country in the field of beekeeping, his dedication of his book to his "guru" Prof. BA Baptist who was primarily responsible for fostering and nurturing his interest in the "fascinating world of the bees", is surely worthy of our respect and admiration.

Dr. C. R. Panabokke
(former Director of Agriculture)

1994 January 30th,

Sudharshana Mawatha,
Nawala, Rajagiriya.
Sri Lanka.

ACKNOWLEDGEMENT

It was in late 1977 I was assigned to study the habits of our honeybee in its' natural environment by my guru, Prof. Bruce A Baptist. This assignment took me to the forested areas of North Central Province where honey hunting was still common and honeybees were abundant. This initial phase was not easy but due to the consistent support of my guru, I was able to overcome all the barriers. I set about my task in the wilderness of Rajarata, by establishing three observational apiaries at Oyamaduwa, Parasangaswewa and Wellikanda in the newly established cattle farms of the National Livestock Development Board. The kind cooperation and help provided by Dr. GS Premachandra (presently at Purdue University, Indiana, USA), Dr. Asoka Gunawardene (presently at the University of Ruhuna, Kamburupitiya), Mr. Palitha Siritunge and Mr. Asoka Kurukulasooriya (both from NLDB) is gratefully remembered.

The late Prof. Gordon F Townsend (then at the University of Guelph, Ontario, Canada) who visited me in early 1978 and recognized the importance of this work helped in several ways to improve the working conditions.

Ever since, I have been helped by many persons to understand the ways of our honeybee, a study which is still quite incomplete. Not the least of them are the honey-gatherers in the forested areas of Anuradhapura (Oyamaduwa, Tantirimale, Parasangaswewa) and Polonnaruwa (Kandakaduwa, Thrikonamaduwa, Dimbulagala) districts and the beekeepers in many parts of the island whose assistance I am unable to acknowledge individually.

I particularly wish to express my sincere gratitude to the beekeepers of the Sri Lanka Dept. of Agriculture, Mr. RMA Ratnayake, the late Mr. RA Sellaperuma, Mr. DC Hindurangala, Mr. WM Amarasekara, Mr. ADS Seneviratne, Mr. PP Premaratne, the late Mr. SA Premasiri and Mr. EM Tissa Bandara who helped me with the management of several experimental apiaries established in various parts of the island on various occasions. Mr. Ananda Jayasinghe, Mr. Jayanath Wickramaarachchi, Mr. Shantha Kodithuwakku, Miss. Sajeeva Elvitigala and Mr. Gamini Herath of this research facility, have assisted me in maintaining the experimental apiaries and in several important behavioural experiments which we were able to conclude within a short period of time due to their sheer enthusiasm.

Prof. Dr. Nikolaus Koeniger and Dr./Mrs. Gudrun Koeniger of the Institute für Bienenkunde (Universität/Frankfurt am Main) at Oberursel, Germany who have been collaborating with me for nearly two decades have not only been a great source of encouragement and support but also took the trouble in improving the manuscripts. Through these collaborative efforts many aspects of reproductive behaviour and management procedures of the local honeybee were established. Prof. Peter Kevan and Prof. Gard Otis (both of Department of Environmental Biology, University of Guelph, Ontario, Canada) have been helpful in several ways. Dr. Thomas E Rinderer's (Honeybee Breeding, Genetics and Physiological Research Laboratory of USDA at Baton Rouge, Louisiana, USA) experiments on hoarding behaviour

and his helpful suggestion were a source of strength and re-affirmation of my own findings to take a turning point in using old combs in effective management. Similarly the experiments on the defence behaviour of Japanese honeybee done by Dr. Masato Ono and his colleagues (Institute of Honeybee Science, Tamagawa University, Tokyo, Japan) re-affirmed my findings on the defensive behaviour of our honeybee which again helped to re-design the management procedures. Dr. Tadaharu Yoshida (Institute of Honeybee Science, Tamagawa University) became a close friend and was constantly in touch and exchanged information on many behavioural aspects and particularly on reproductive behaviour. Prof. Siriwat Wongsiri (Bee Biology Research Laboratory, Chulalongkorn University, Thailand) and Prof. Mrs. Ruth Kiew, and Dr. Makhdzir Mardan (University Pertanian, Malaysia) exchanged information on several aspects of the behaviour and management of Asiatic honeybees.

I gratefully acknowledge Dr. CR Panabokke former Director of Agriculture for writing the foreword and various help rendered during his tenure and afterwards for the cause of honeybees. My appreciation goes to Dr. HME Herath, former Head of the Division of Agricultural Research, Mr. S Wirasinghe, Head of the Division of Agricultural Technology Transfer, Mr. Percy Abeywardene the former Head of Agriculture Extension, Dr. SL Amarasiri, present head of the Division of Agricultural Research and Mr. GA Goonatillake the former Head of Agriculture Research Station, Bombuwala of the Sri Lanka Dept. of Agriculture for the encouragements and institutional support. I sincerely thank, Dr. SPR Weerasinghe, Director of Agriculture, for writing the preface and encouragement given towards my work from my early days in the Department of Agriculture.

Mr. Bandula Jayawardena (former Editor-in-Chief, Encyclopedia of Buddhism, Ministry of Cultural Affairs) and Mr. Narada de Silva (formerly of Sub-Department of English, Universities of Peradeniya and Colombo) scrutinized the manuscript thoroughly in spite of their busy schedules of work. The discussions with and the suggestions made by Mr. Noel Wijayagunasekara (Head, Dept. of Agricultural Biology, University, Peradeniya), helped in the organization and improvement of the text. Mr. George Lanerolle (Assistant Director of Agriculture for Beekeeping) and Mr. Ananda PR Jayasinghe (Assistant Director of Agriculture) helped by making several suggestions to improve the manuscript.

The discussions with the members of the Sri Lanka Bee Farmers' Association, particularly with Mr. Lacelot Peris, Mr. Alec Dias Bandaranayake, Dr. Mrs. Thelma Gunawardena, Mrs. Jessica Alles, Mrs. Seetha Jayasinghe, Mrs. Sushilla Kumaraswamy, Mr. EH Romanis, Mr. GMS Piyaratne, Mr. PV Joseph, Mr. Lionel Fernando and Mr. Edmund Mallawaratchie made a worthy contribution. Mr. Ivor de Abrew of Bandarawela (presently at Nikapotha) not only contributed through most stimulating discussions but also kept his entire apiary at my disposal for finding ways to help beekeepers.

My wife Dr. Lakshmie Punchihewa, provided the necessary home and family background to watch bees closely. Our daughters, Varangana and Rangani, encouraged my work with bees by watching flower visiting insects on their own and asking questions for which I did not have answers.

My special thanks are due to Canadian International Development Agency which for so many years supported my work (CIDA Projects #270/00402 1977~1984: #270/08307 1985~1989: #270/12061 1989~1993) and finally undertook to publish this book. But for their keen interest this work would not have seen the light of day. I am particularly in debt to two CIDA officials who served in Sri Lanka, Mr. Henri Lafortune and Mr. Alain Daudrumez for their cooperation, *par excellence*. The former became a true sympathizer and ardent supporter of the cause of the honeybees. The scholarships and research grants given to me by German Academic Exchange Service (DAAD reference #325/817/005/8 1988, #325/817/002/1 1991~1992) and Natural Resources, Energy & Science Authority of Sri Lanka (NARESA research grant #RG/ 91/B/4 1992~1994) and Sri Lanka Council for Agricultural Research Policy (CARP Project #12/92/74 1992~1996) have served in generating some of the important aspects in the management of honeybees presented in this book.

Writing of the book has been by and large a pleasure. I was able to retrieve some of the best memories of my life, though at times I cursed the project. It taught me things I never knew about bees and myself. Now, I have a great respect for those who write books.

Though many people mentioned and not mentioned, directly and indirectly helped me to complete this work, all errors, omissions and inconsistencies that may remain, are my own. Finally, I thank all those who helped me with this task and the staff of Sarvodaya Vishva Lekha Press for putting it into present form.

R.W.K. Punchihewa

1994 February 17th

**Honeybee Research Facility,
Horticulture Station,
Kananwila, Horana.
Sri Lanka.**

Of Honeybees and Honey Hunting

Of what they did and said in the past when gathering honey as Spittel (1945)¹ saw and recorded.

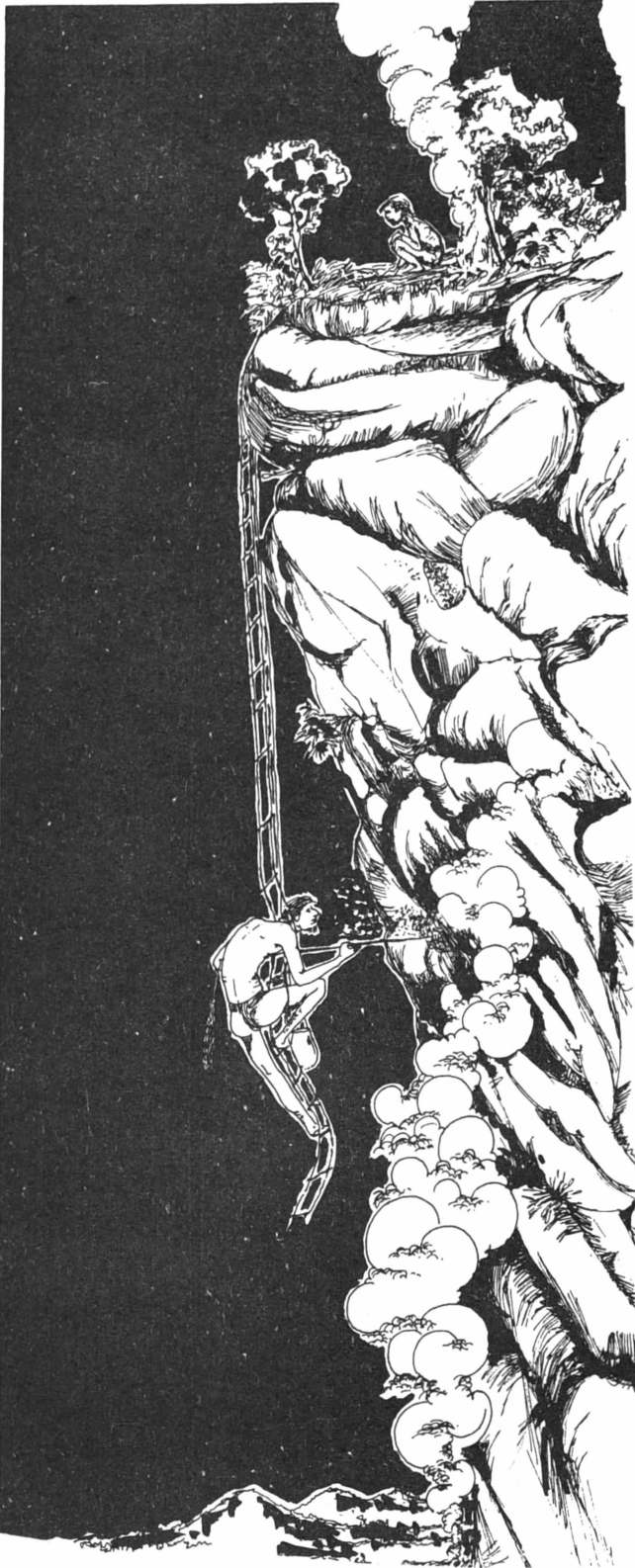

A pile of firewood now collected on top of the rock to protect the guardians of the ladder, while another heap is made by those below. All being ready they await the protecting darkness. When this comes the play begins."

The Cliffhanger Episode

"The Bambara Bees attach their hives (nests) to the lower surface of the forehead like projectives of rocks which rise steeply over the landscape.....

...A tree (on top of the rock) provides anchorage for the life line for the honey hunter who descends to reach Bambara nests.

But when the hill is too lofty for this, as usually happens, the ladder hangs free, and the gatherer may even have to swing to and fro to enable him to get at the combs. Nor is this all; the bambaras, several of which may kill a man, have to be reckoned with; they can only be dispersed by heavy smoking; and, what is worse, when several hives are clustered together in a colony, the work has to be done on a pitch dark night.

Imagine then the picture of the man smothered in smoke, assailed by angry bees, swinging in the darkness two hundred feet (about 60m) or more above the stony earth, with neck and knee hitched to the ladder so as to leave the arms free to manipulate torch and prong. Is it a wonder that every Vedda is not a *kapunkaraya* or cutter, but only the boldest of them; and that he, when he descends to his work, does so without thought in his heart of life or father or mother?

Lastly, there is the *hangotuwa* (deer-skin receptacle for the honey), or *yakka-katte* (devil's mouth) as it is reverently called out of deference to the tutelary demons of the rock, who might otherwise be angered and send the cutter to his doom.

¹Spittel, RL (1945) Wild Ceylon, VI Veddass of Bingoda 5. Nests & Hives. pp. 86-90. Printed by Ceylon Daily News, 1945 for General Publishers Ltd., 20, Parson's Road, Fort, Colombo. (1928 Ed. The Colombo Apothecaries' Co., Ltd. Colombo.)

■ The whole process of honey gathering was started off with an invocation and honey was sprinkled in different directions invoking the names of deities. *Bambara Kavi* or *Maligi* were recited while the honey was being collected. An invocation.

"A group be at the top of the ladder (life line),
A group be at the bottom of the ladder (life line),
The ones go in ladder be well prepared,
Nothing offensive in smoking the Bambara in the rock "

වැල ඉද්දර සේනාවක් සිට පල් ලා
වැල පාඩුල සේනාවක් සිට පල් ලා
වැලේ යන දෙන්නා සේවි පලයල් ලා
වස් නැති ගල් බමරෙට දුම්දාපල් ලා

Dep (1956)²

■ The great fire at the foot of the rock is lit and fed abundantly with green leaves; large volumes of smoke lick uncannily up the side of the hill towards the hives; now there is a stir among the bees. As the Veddas hear it their merriment waxes great.

"The bees, the bees, the bees;
pile the fire, pile the fire, pile the fire.
Ho! the bees run, Ho! the bees run, Ho! the bees run "
they jeer in imitation of the flight.

බමරු, බමරු, බමරු,
කපිට, කපිට, කපිට,
හෝ බමරු දුවපා,
හිඩි, හිඩි, හිඩි, රු, රු, රු

Spittel (1945)¹

■ An invocation sung for the demons of the rock and ancestral spirits while cutting the honey combs

"O! Omungalla (a name of the rock) Sovereign!
Mother-by this respect (paid to you, be my guide)-
Who protects (us) by (your) great authority!
Having cut and lowered the (ladder of) great cane,
Having driven off (the bees) by the shield of smoke,
Having cut (the comb) with the sword,
Having put (it) down into the vessel,
Having fetched the sweetest honey. Bring (it),
Bring (it) (for us) to eat, to lay aside (our) hunger "

රජ මුමුනගලේයා,
මා ගුරුවෙන් අම්මා, ගුරුබලේ රකින්නා,
මාවේවැල් කපල බස්කලා, දුම් පිලියෙන්
පත්තලා,
කඩුවෙන් කපලා, පලියට දමලා,
මීරේ මීරිය පැණි ගෙන දෙත්,
ගෙනෙන් ගෙනෙන් බඩහිනි ඇරෙන්න
කන්න.

Seligmann & Seligmann (1911)³

■ Pious folk frown on this sinful practice and possibly there is a body of poetry of the type given below to discourage this manner of gathering honey.

"In the name of the mother (I say) Bambara do nothing wrong.
They feed and live on wild flowers.
Does no harm to any cultivation.
The one who cut Bambaras (destroy to get honey) will end up in hell "

අම්මා පල්ල බමරුන් අත වරද නැ කි
කැලේ තියෙන මල් බිලා උන් රැක කි
අනුන් කරන ගොවි පොළකට පාචනැ කි
බමර කපන අය නරකාදියේ ය කි

Dep (1956)²

Therefore then, indulgence in a more humane pursuit such as rearing Mee Bees for honey production is desirable and environmentally friendly. The fact that honey from Mee Bees is considered a highly valued item in indigenous medicine⁴ and a medicinal food gives all the more reason to practise **Beekeeping for Honey Production.....**

² Dep, AC (1956) The Collection of Bambara Honey in Uva, J. Royal Asiatic Soc. (Ceylon Branch) NS 5 : 42-67

³ Seligmann, CG & Seligmann, BZ (1911) *The Veddas*, Cambridge University Press, England.

⁴ Jayasinghe DM (1976) *Garlic & Honey* (in Singhala, by The Department of Indigenous Medicine, Colombo.)

ජයසිංහ, ඩී. එම්. (1976) දිව මසු-දිව බොජුන්, ශ්‍රී ලංකා අපූර්වද දෙපාර්තමේන්තුව, කොළඹ.

INTRODUCTION

“What we have to learn to do, we learn by doing”

Aristotle (384-322 BC)

Nicomachean Ethics II

“Nature to be commanded, must be obeyed”

Francis Bacon (1561-1626)

Novum Organum

Production of honey by honeybees is one of the fascinating phenomena in applied biology. It is not only a biological fascination but a process that has a direct economic value.

Beekeeping for honey production is essentially an operation in field biology. The beekeeper has to coordinate the activities of two groups of organisms, the nectar producing plants and the honeybees, at an optimum level.

This work discusses the biological background and the management procedures involved in utilizing Sri Lanka's indigenous honeybee, *Apis cerana indica*, for honey production in her natural environment.

Anyone who is willing and able to handle honeybees can develop the necessary skills in utilizing them for his or her advantage, provided the environmental factors are conducive. This work is primarily intended for school leavers and others who seek a source of employment and income; where they are able to engage in an occupation in their own villages to supplement family income and nutrition.

To gain competency in managing honeybees one has to know their ways by working with them. As such this work is an introduction to this rewarding activity of which the bulk has to be learned from the observations on honeybees themselves.

Many income generating pursuits, agricultural or otherwise have a detrimental impact on the natural environment, whereas beekeeping has none. In fact the honeybees would stabilize and improve the environment. Conservation of honeybees and other bees should be an intended aspect in environmental conservation. In this regard an appropriate motto will be "protect the bees to protect Nature". Sri Lankan villagers knew the importance of bees by tradition and therefore they considered honeybees nesting in the home garden as a sign of prosperity and good luck while the departure of the colony was considered a bad omen. This belief of the villagers demonstrate innocent but insightful awareness into the intimate relationship between the functions of the honeybees with Nature and human life, which is a part of it.

In a modern context of human activity, productivity and prosperity seem almost synonymous in spite of the fact that productivity is always achieved with some degree of detrimental influence on the environment. Fortunately environmental conservation has also become an issue of major importance.

However we must be all the time aware that the pressing need for simultaneous environmental conservation and increasing productivity has met each other in conflict. The development of technology based on understanding and inquiry is needed to mitigate and harmonize these two polarizing factors in order to complement each other rather than compete. The honeybees offer a good possibility in achieving this.

“ ehi passiko ”

“ Come and see for yourself ”

Gotama the Buddha (563 - 483 BC)

DEDICATED

TO

Professor Bruce Albert Baptist

Retired Head, Dept. of Agricultural Zoology, University, Peradeniya, Sri Lanka

Who fulfilled the tiresome and difficult task of laying the technological foundation that was essential for the development of the Beekeeping Industry in Sri Lanka

and

IN MEMORY OF

The Late Professor Gordon F. Townsend

Dept. of Environmental Biology, University of Guelph, Ontario, Canada

Who eagerly offered the needed resources that were essential to build the technological foundation of the Beekeeping Industry.

Both these men made the base to carry out the necessary work today to develop a new industry.

Also in

TRIBUTE TO THE PIONEERS

Mudaliar Samuel Jayatillake

Who lived in Wattedgama, near Kurunegala in the middle part of the 19th century for having realized the destructive nature of honey hunting and for introducing honeybee culture to Sri Lanka,

Mr. A. P. Goonatillake

Who lived near Veyangoda and made indefatigable attempts to make beekeeping a viable cottage industry in Sri Lanka during the early part of this century,

and

Mr. Charles Drieberg

The founder Secretary of the Ceylon Agricultural Society, who had taken much effort to popularize beekeeping in Ceylon (Sri Lanka) and later included beekeeping as a subject of study and area of developmental activity of the Ceylon Department of Agriculture from its inception.

PREFACE

From time immemorial the art of bee's honey extraction, in Sri Lanka, was developed and practised for use principally in indigenous medicine. The wide expanse of natural forests provided an ideal sanctuary for the honeybees to thrive and produce honey from a wide variety of flowers that blossomed over an extended period of time. With rapid human population growth and the progressive denudation of forests, in the past few centuries, bee's honey production from the natural forest reserves has been rapidly declining. On the contrary there has been a significant increase in the demand for bee's honey for the preparation of cosmetics or direct use to obtain the known beneficial effects on vigor and vitality.

This increasing demand, therefore, necessitates a rapid change from traditional methods of extracting honey, towards the development of modern, scientific methods of domestic beekeeping. Such changes include scientific study and adaptation of the honeybee to the environmental conditions that obtain in the country. Many attempts made in the past to directly translate the beekeeping technology developed for over a century in the Western World with the honeybee, *Apis mellifera*, to the local honey bee, *Apis cerana indica*, had not been very successful.

Numerous studies made in Sri Lanka with the indigenous honeybee has clearly shown that its behaviour is distinctively different to the *Apis mellifera* found in the West. This compendium on beekeeping has collated the present knowledge on the local honeybee, *Apis cerana indica*. The comprehensive, well illustrated, documentation on the scientific management of the indigenous honeybee will undoubtedly benefit the present and potential beekeeping entrepreneurs. Nationally it can contribute towards increasing honey production to meet the rising demand from a wide spectrum of users.

Such a pioneering effort by a scientist of the Department of Agriculture is, indeed, a reflection of and testimony to his dedication and commitment to beekeeping. And more significantly an invaluable contribution to a facet in the country's agricultural development.

I, therefore, recommend this publication to scientists, professional beekeepers, amateurs and students who can immensely profit by getting an insight into the intricate aspects associated in the honey making process by our indigenous honeybee.

Dr. S. P. R. Weerasinghe
Director of Agriculture

1994 January 25th,

Dept. of Agriculture,
Peradeniya,
Sri Lanka.

1. Bees and Beekeeping

1.1. Bees

In the course of organic evolution on earth, after the arrival of flowering plants about 70 million years ago a group of wasps abandoned their carnivorous wasp habits and transformed gradually to depend on flower nectar and pollen for their nutrition. These wasps changed to herbivorous habits and became a group of specialized flower visiting insects called **Bees**. From about 285,000 species of flowering plants existing in the world today more than 65% of them need insects for successful fertilization or pollination to produce their fruits and seeds. Insects which are about 800,000 species in the world, 20% of them depend on flowers for their food. Among flower visiting insects, the Bees especially have developed a very close association with flowers. Therefore the bees have acquired specialized life styles and bodily adaptations to live on flowers. Bees are numerous with over 20,000 species grouped as **superfamily Apoidea** in the insect order *Hymenoptera*. The Wasps and Ants too are members of the order Hymenoptera and have some close resemblance to bees. Table 1.1 briefly highlights the systematic positioning of the bees among the other animals of the world.

Among the bees one can see a wide spectrum in social organizations, ranging from solitary bees who live alone in their nest to highly organized colonies of honeybees (**genus *Apis***) with thousands of individuals living together as one large family, which is sometimes referred to as a "super organism". Man, himself a highly social animal, has paid a substantial attention to the highly social honeybees (**family *Apidae***). Social bees comprise only a minority among bees and over 85% of the bees are Non-Social and often escape the attention of the layman. Large carpenter bees (**genus *Xylocopa***) who build nests by drilling holes in low quality structural timbers and in dead trees are also types of bees who live as a small family and are rather common (see Section 10.6.1, Table 10.6 and Figure 10.2). Bees who have evolved as specialized flower visiting insects render a yeomen service to nature as pollinators of plants.

Man who arrived less than a million years ago on earth, which was long after the arrival of honeybees would have been dependent on them for his food. From pre-historic times man learned to get honey and bee brood for his food by plundering the nests of honeybees. This habit continues upto this day in some places in Sri Lanka and in some other countries of the world. As much as our ancestors benefited from bees in earlier times, even today we derive many direct and indirect benefits from bees.

1.2. Honeybees

Among many thousands of species of bees, there is a group called "**honeybees**" who live as groups of many individuals and store honey in their nests consisting of waxen combs. Each wax comb consists of a vertical sheet of wax which has hexagonal cells on either side, suspended along the upper boarder by attachment to the top of the nesting site. Honeybees store flower nectar as honey and pollen as a honey mixed paste in their nests. Further

Table 1.1: A Brief Systematic Positioning of Bees Among Other Animals of the World.

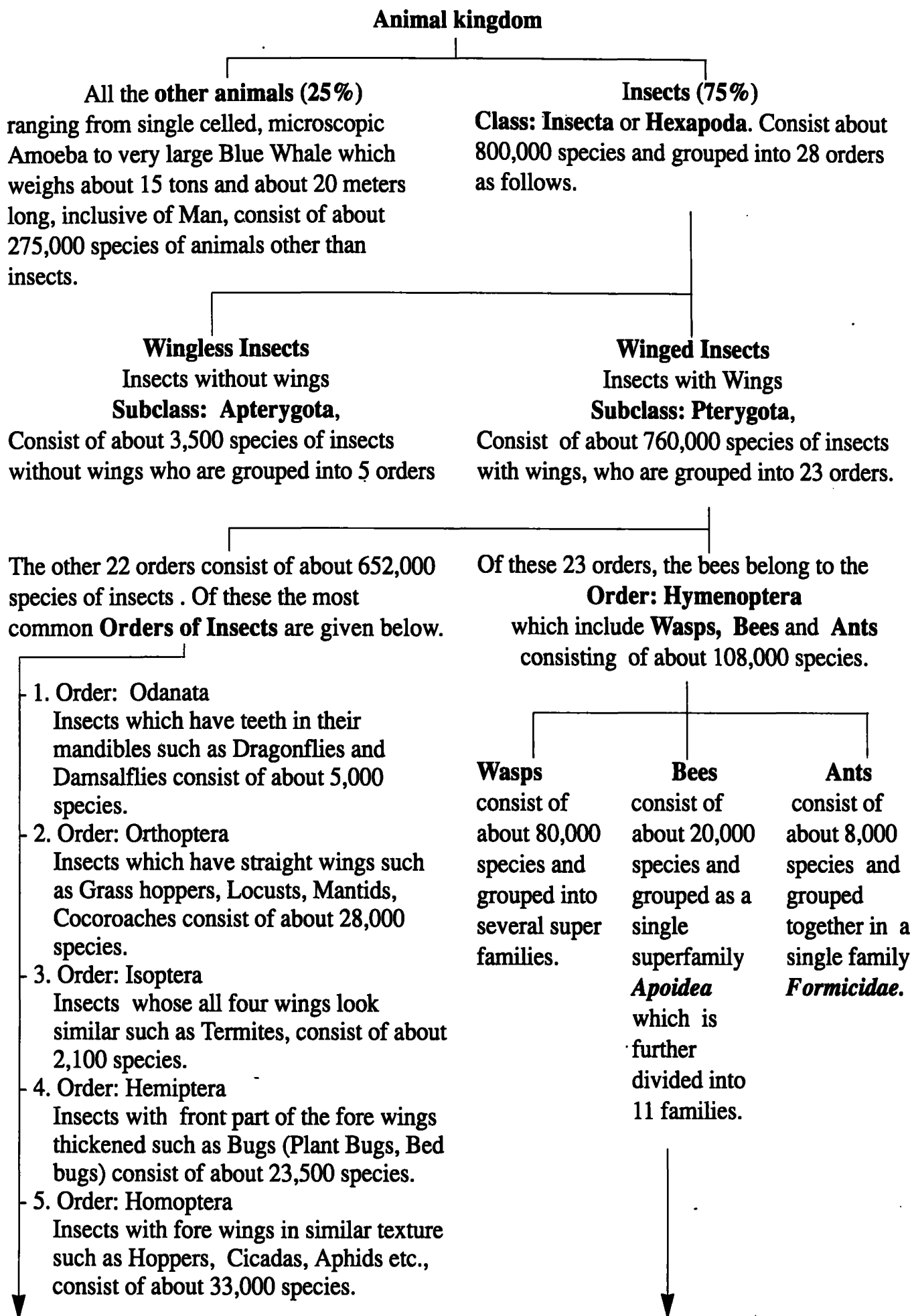

6. Order: Coleoptera
Insects with hard leather like (elytra) fore wings such as Beetles consist of about 300,000 species.

7. Order: Lepidoptera
Insects with colourful wings due to the colourful scales covering them such as Butterflies and Moths consist of about 113,000 species.

8. Order: Diptera
Insects with only one pair of wings such as Flies, Mosquitoes, Fruit flies consist of about 120,000 species,
Are included in these common orders.

Note: Bed bugs do not possess wings but majority of Hemipterans do.

Sources of Information

1. Storer, TI & Usinger, RL (1965) General Zoology 4th ed. McGraw-Hill & Kogakusha. NY, London, Tokyo etc.,
2. Borrer, DJ; DeLong, DM & Triplehorn, CA (1981) Introduction to the Study of Insects. Saunders College Publishing. NY, London etc.,
3. Ruttner, F (1988) Biogeography and Taxonomy of Honeybees. Springer-Verlag. Berlin, NY, London etc.,
4. O'Toole, C & Raw, A (1991) Bees of the World. Blandford, London.
5. Apidologie:
A journal published by Elsevier Science Publishing. NY & Paris - several reports since 1988 on discovery of new species of honeybees.

* The hive honeybee of the Indian sub-continental region and of Sri Lanka is called *Apis cerana indica*. The other well known sub-species are *A.c. cerana* and *A.c. japonica*.

Bees

Super family: Apoidea

Divided into 11 Families

1 2 3 4 5 6 7 8 9 10 11

The Family that includes honeybees is called

Family: *Apidae*

Honeybees

Depending on the possession of the sting further divided into two sub families

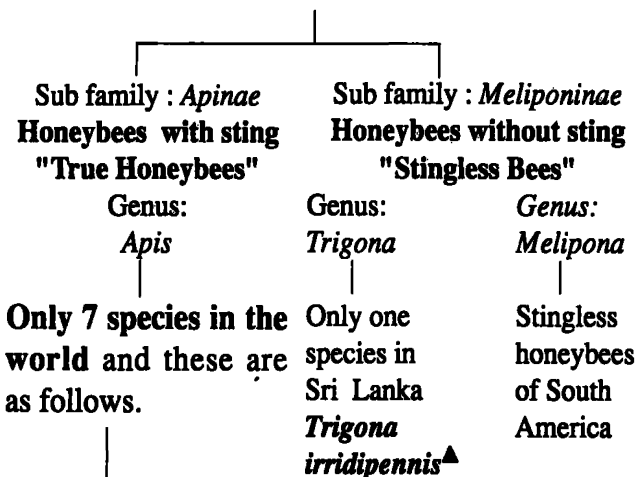

1. *Apis cerana**[▲]
Asiatic hive honeybee or Mee Bee
2. *A. koschevnikovi*[▲]
Red hive honeybee of Borneo
3. *A. mellifera*[▲]
African and European hive honeybee
4. *A. dorsata*
Giant honeybee or Bambara Bee
5. *A. laboriosa*⁺
Himalayan Giant honeybee or Himalayan Bambara bee
6. *A. florea*
Little honeybee or Danduwel Bee
7. *A. andreniformis*
Another Little honeybee or Danduwel Bee of Thai-Malayan region

[▲] Could be reared in enclosed containers or Hives.

⁺ There is a controversy as to whether a separate species or a sub-species of *A. dorsata*.

honeybees could be considered as "stinging honeybees" and "stingless honeybees". In Sri Lanka there are four species of honeybees.

There are three species of "Stinging Honeybees" or "True Honeybees" in Sri Lanka:

- 1 **Hive honeybee** - The scientific name is *Apis cerana indica* and the nest of this honeybee which is built in an enclosed space is shown in Figure 1.1. In popular vernacular it is known as "Mee Bee".
- 2 **Giant honeybee** - The scientific name is *Apis dorsata* and the nest of this honeybee which is built in an open space is shown in Figure 1.2. In popular vernacular it is known as "Bambara Bee".
- 3 **Little honeybee** - The scientific name is *Apis florea* and the nest of this honeybee which is built in an open space is shown in Figure 1.3. In popular vernacular it is known as "Danduvel Bee".

There is also a single species of "Stingless Honeybee" in Sri Lanka:

- 4 **Dammar Bee** - The scientific name is *Trigona irridipennis* and the nest of this honeybee is shown in Figure 1.4. In popular vernacular it is known as "Kanawe Bee".

Stinging honeybees defend their nests from intruders by stinging them with a poisonous sting while stingless honeybees chase away their intruders by biting. The hive honeybee and stingless honeybee build their nests in naturally protected dark places such as hollow tree trunks, termite mounds or rock cavities. The giant honeybee and the little honeybee build their nests in open places which consist of only a single comb. It is relatively easy and profitable to rear hive honeybees. Figures 1.1 to 1.4 illustrate the nesting habits of 4 species of honeybees in Sri Lanka.

1.3. Rearing Bees

Rearing of bees in a broader sense is called **Apiculture**. Apiculture has to do with the management and scientific background for the management of honeybees, usually for **honey production** or **wax production** or for **crop pollination**.

Beekeeping refers to rearing of honeybees usually for honey production. The one who rears honeybees is called a **beekeeper** or an **apiarist** and the place in which the bees are kept called **Bee Yard** or the **Apiary**.

In this book, the emphasis is made for the production of honey with the Sri Lankas' indigenous hive honeybee, *Apis cerana indica*.

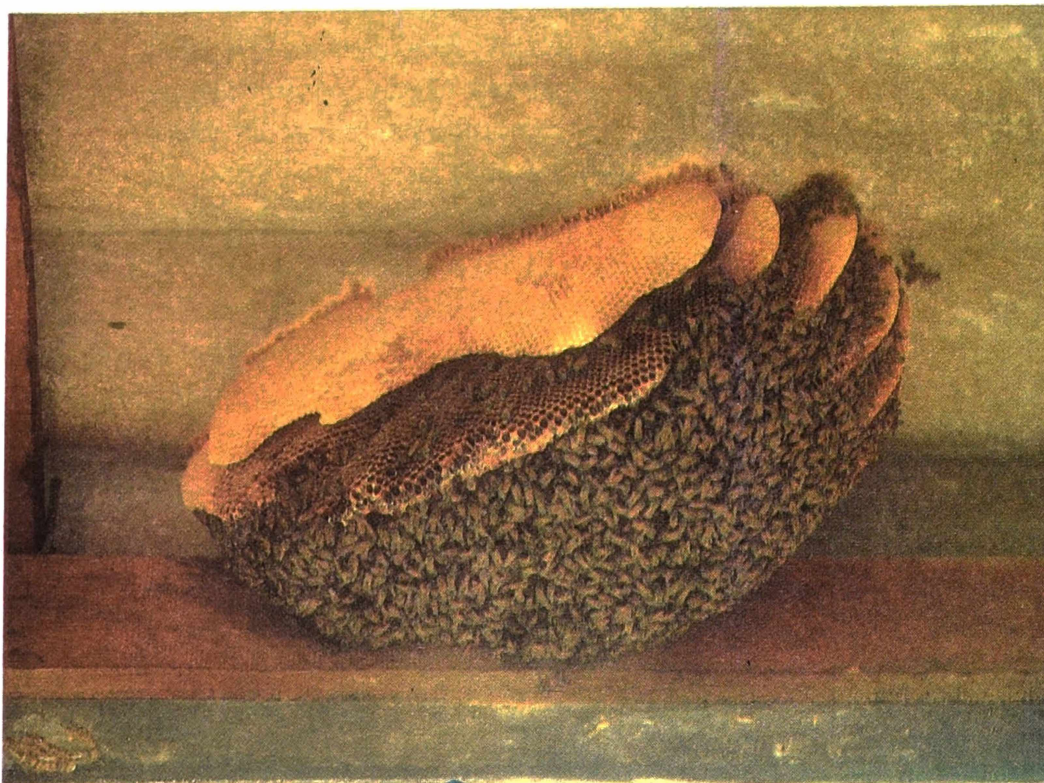

Figure 1.1: The concealed nest of **Mee Bee** or the hive honeybee, *Apis cerana indica* with several parallel combs are built in a protected site underneath a roof. This was concealed between the roof and the ceiling in a house. (Completely suspended and completely enclosed nest)



Completely Suspended Nests of Honeybees.

Figure 1.2: The Exposed single comb large nest of the **Bambara Bee** or the Giant honeybee, *Apis dorsata* is built underneath a branch of a tree. (The nest is covered from top and completely suspended and exposed)

Protective Layers of sticky resins applied on either sides of the twig where the nest is build prevents any intruding predatory Ants. →

Figure 1.3: The exposed single comb small nest of **Danduvel Bee** or the Little honeybee, *Apis florea* builds its nest around a twig of a tree and hangs down.

Semi Suspended and Fully Prostrate Nests of Honeybees

Nests of stinging honeybees are constructed with wax and suspended from the substrate above.

Nest of stingless honeybee is constructed with a mixture of plant resins and wax and consists of a cluster of special pots which contain food stores and brood. This nest is deposited (prostrate) on the bottom of the nest site or a protected cavity.

In figure 1.4 relatively large and brownish honeypots are on the left and smaller whitish brood pots are in the centre.

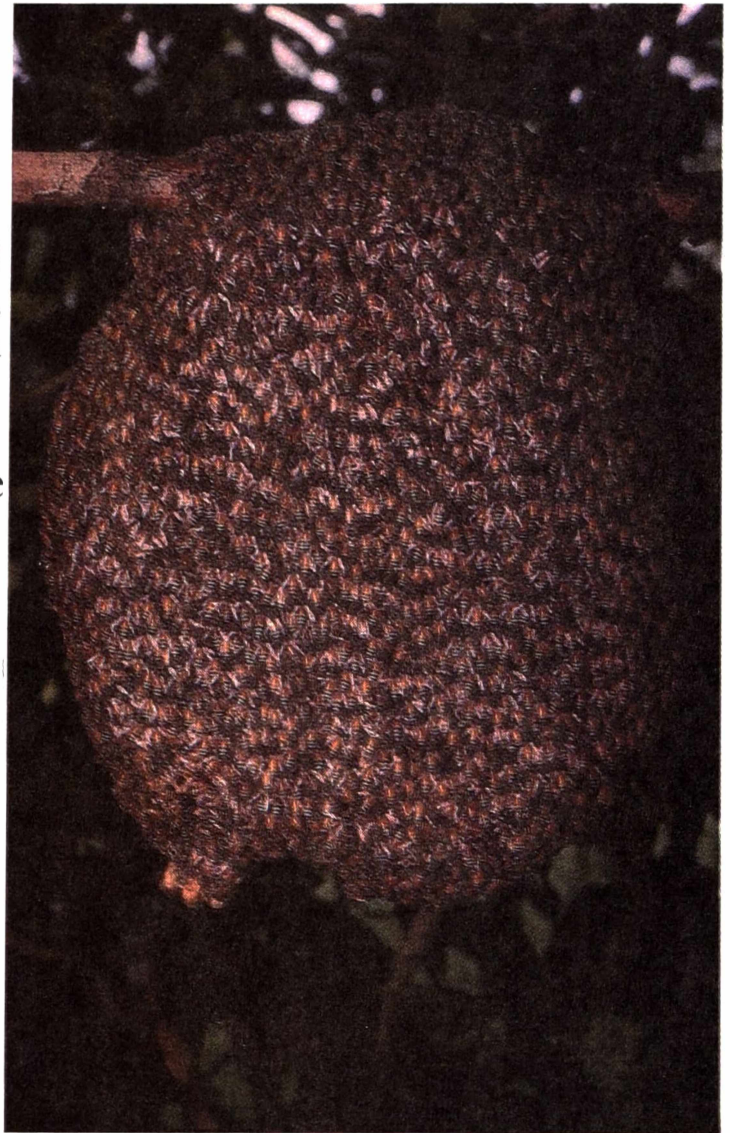

Figure 1.4: The concealed nest of **Kanawe Bee** or the Dammar honeybees, *Trigona irridipennis* is built inside a box. The top lid is removed to expose the nest.

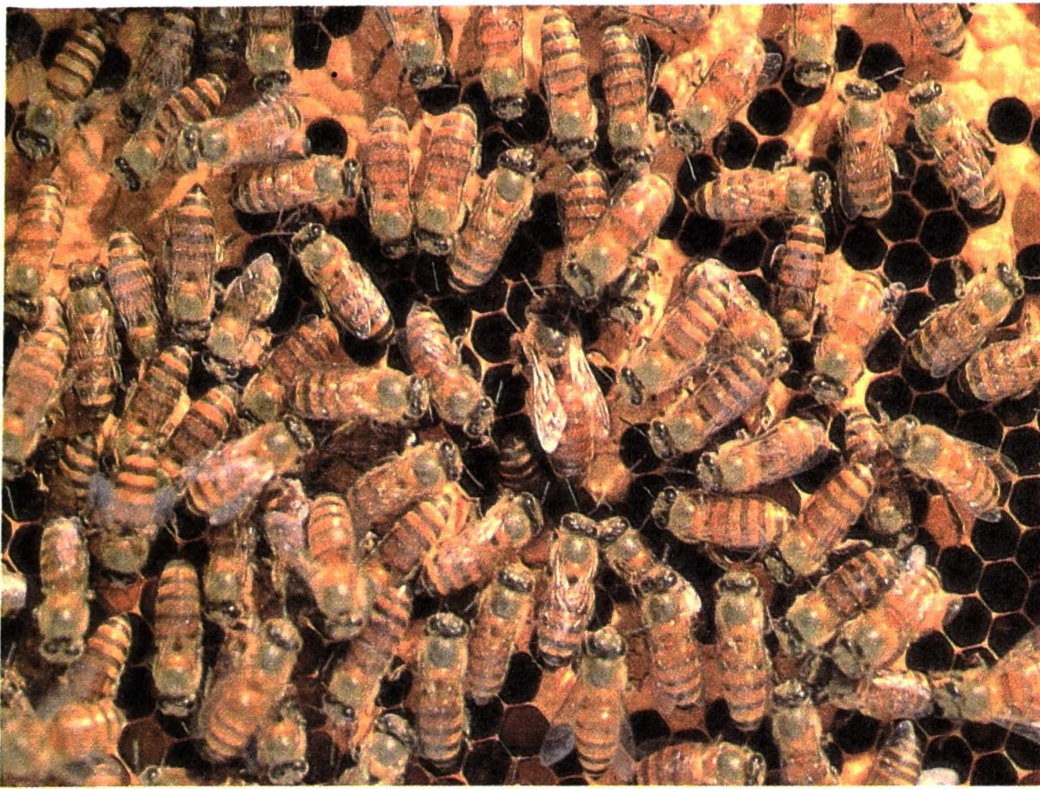

Figure 1.5: *A. cerana* queen among her court. The worker bees surrounding the queen constantly lick her and feel her with their antenna to receive the queen-substance (a pheromone) and also feed her. This distinct circular arrangement of bees surrounding the queen or the "**Court Formation**" is important in maintaining the social balance or the "**Social Homeostasis**" (see Glossary, p. 213) of the colony.



Figure 1.6: *A. cerana* queen laying an egg. Only the thorax is visible as she has inserted the abdomen into a cell to deposit the egg. While egg laying too the "**Court Formation**" is kept unchanged where the worker bees constantly surround her to receive the queen-substance and to feed the queen.

The container or the nesting site provided by Man to house a nest of honeybees is called a **Hive**. Therefore the hive is an artificial nesting site, which Man has designed for his convenience of manipulating the nest of honeybees. The construction (the wax combs) made by the bees in the nest site in which the young are reared and the adults live with their food stores is collectively called a **nest**.

The scientific study of any or all groups of bees, that is, the super family Apoidea, which consist over 20,000 species is called **Mellitology** or **Apiology**. Table 10.6 (p. 194) gives a brief description of the families of bees.

1.4. A Honeybee Colony

1.4.1. The Colony Life

A **Colony** is the term used to denote a group of insects living in a common nest, which they have constructed, working together to supply each other's needs and cooperating to raise the offspring. Most colonies of social insects (such as Ants, Wasps, Bees & Termites), including the honeybees are large families in which the mother lives long enough to work in cooperation with her offspring. This single mother, the only fertile female in the colony, is called the **queen**. The most important function of the queen is to lay eggs to produce her offspring (Figures 1.5 & 1.6). Immature stages of honeybees are collectively called the **brood** and the majority of the eggs laid by the queen produce worker bees or the daughters. Figures 1.7 and 1.8 illustrate the immature stages of the worker bees from egg to adult. The daughters, who are sterile, produced in thousands, are called the **workers** and they attend to all the other functions important for the survival of their colony, such as food gathering, care of the young, nest-building, cleaning, defence, making honey, temperature regulation etc. The male honeybee is called a **drone** (Figure 1.9) and is important in mating with the young reproductive females or the **virgin queens**.

The honeybee colony lives on and between a number of **combs** which it constructs from **wax** produced by the workers from their **wax glands** in the body. This construction is called a **nest**. Such nests of honeybees are usually situated in dark protected places (Figure 1.1), such as hollow tree trunks, rock crevices, etc. The combs are two-sided and are composed of hexagonal cells. The combs contain **stored honey** at the top, followed by a layer of stored **pollen** and below are the **brood** of all stages.

A colony of honeybees during the peak population period usually contains one queen, 25,000 to 30,000 workers and a several hundred drones. The peak population is achieved during times of abundance of food when the availability of nectar and pollen is plentiful. During such periods the colonies reproduce themselves by making new queens through a process which is called **swarming**.

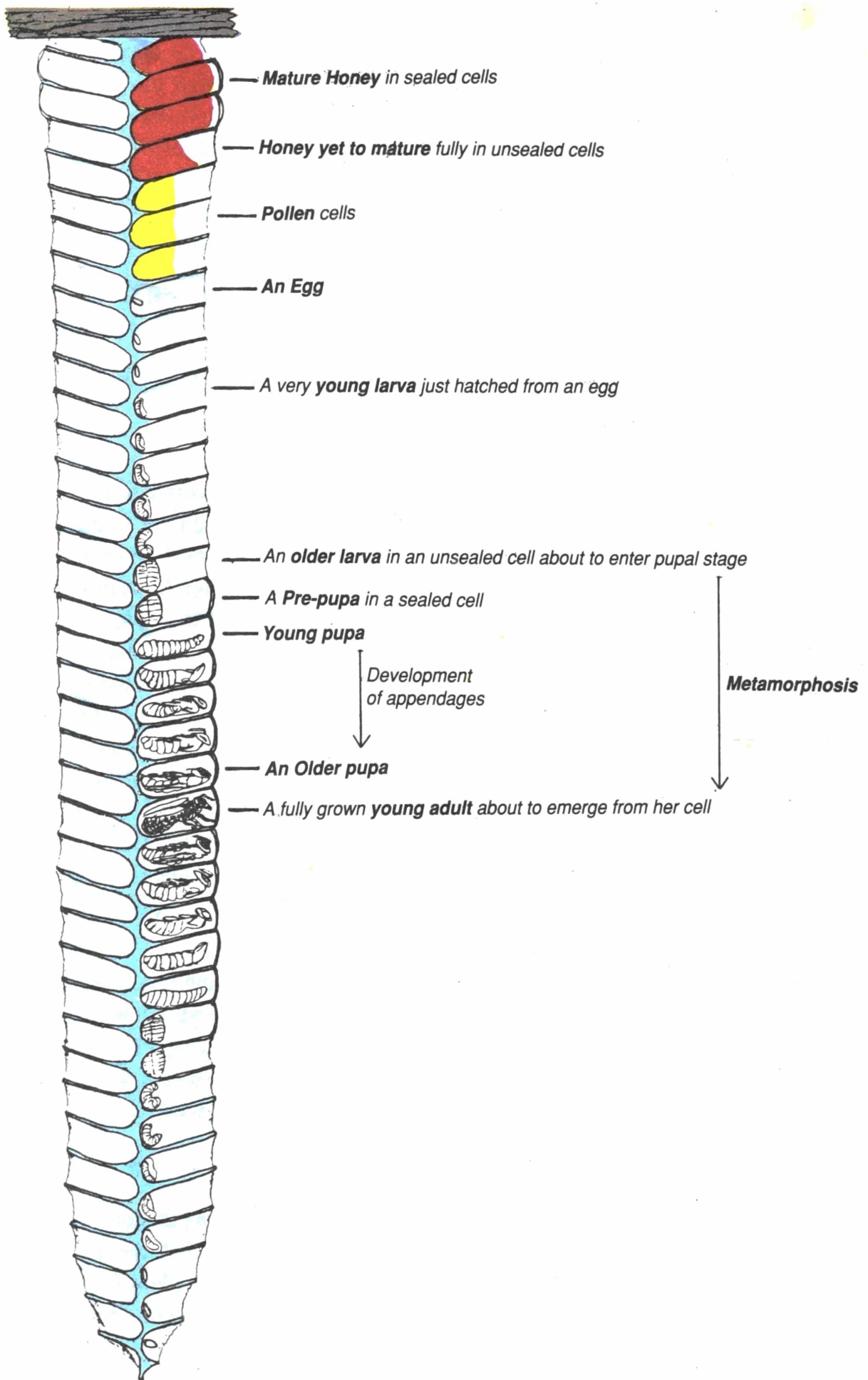

Figure 1.8: The brood section of worker honeybees in a comb and their various developmental stages.

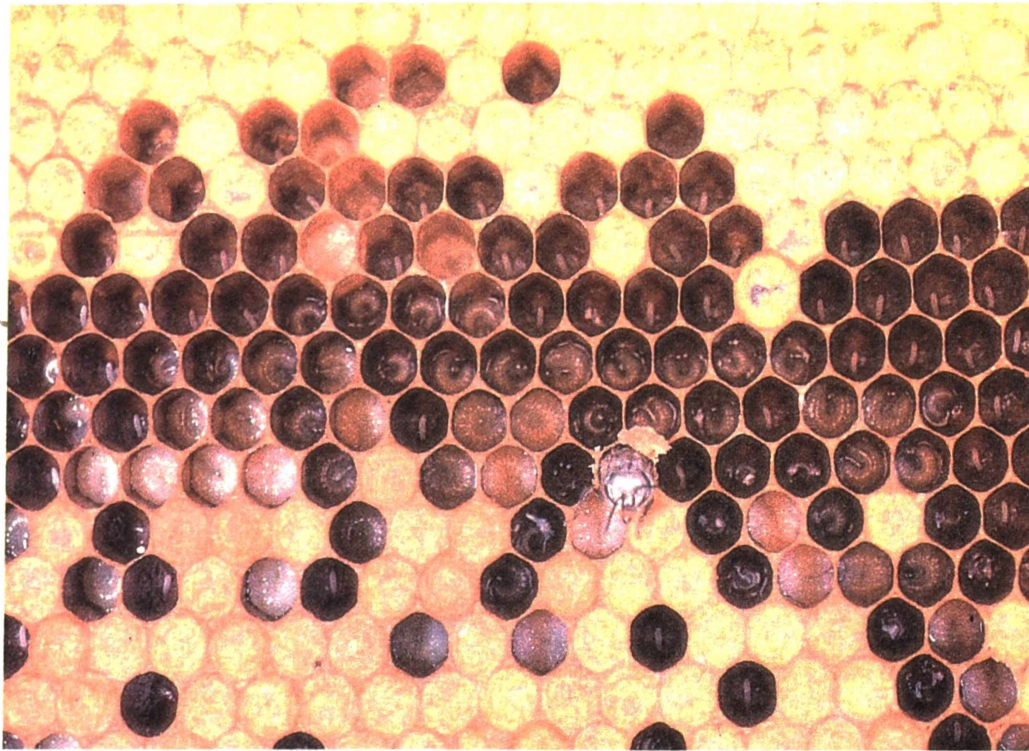

Figure 1.7: A part of a comb containing honeybee brood (Eggs, Larvae & Pupae). The tiny white rods on the bottom in some of the hexagonal cells are eggs. Small larvae hatched from eggs are seen floating on a blob of their food. Larvae at various stages of growth are seen. The older larvae, grown in body size, fill the entire space in a cell. Once the larvae are grown large enough they enter the pupal stage and then their cells are sealed with a wax capping. A young adult worker bee is seen just emerging out of her cell after cutting through the capping.



Figure 1.9: A drone or the male honeybee among his sisters. It is easy to distinguish him due to his stout body, dark colour and large eyes compared to workers.

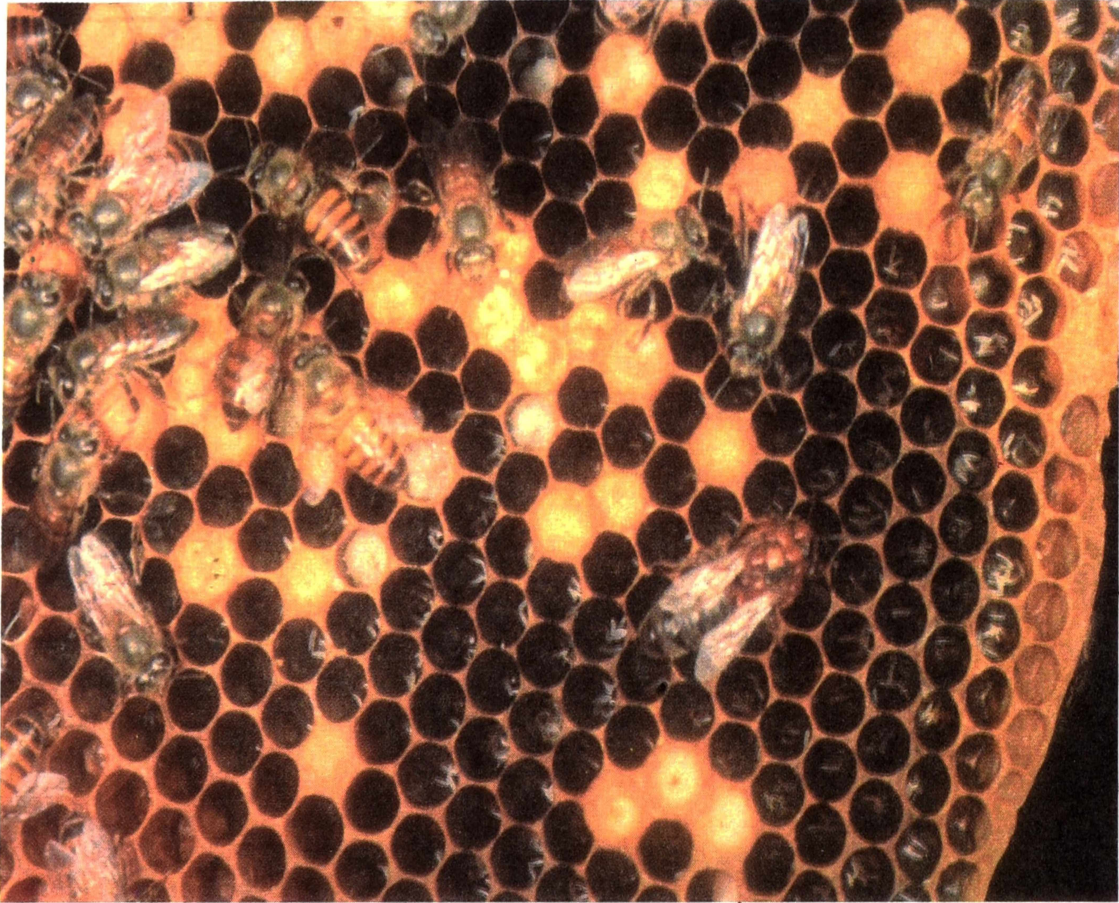

Figure 1.10: An orphan colony of *Apis cerana* due to the breakdown in its social homeostasis. As a result of the existing queen approaching sterility the queen substance production and supply by her has fallen below the critical level (To locate the sterile queen project the arrow marks to the picture). Due to this the "Court Formation" around the queen is completely absent where the worker bees do not lick and antennate her or attend to her any more. Therefore now the queen's head and thorax regions are covered by an inquiline **bee louse**, *Braula coeca*, (*Diptera*: *Braulidae*) who is able to colonize her without a problem. The other effect is that, due to the insufficiency in the supply of queen substance some of the workers have developed their ovaries and started to act as "pseudo-queen" (false-queen) or "laying worker". These laying workers lay more than one egg per cell and in the picture several eggs per cell can be seen. However, these eggs will develop as drones but not as workers.



Figure 1.11: A worker honeybee sitting on a top-bar exposes the Nasonov gland situated at the last segment of her abdomen to liberate pheromones (the orientation pheromones) to the air to invite her nest-mates to the hive. The hive was opened and smoked causing many bees to fly away. This worker is calling them "come home, we are here" by sending pheromone signals.



Figure 1.12: "Liquid Transfer". A house bees at the top through her extended proboscis receives nectar from the foraging bee (below) after returning from a foraging flight. The forager regurgitates the nectar to be sucked up by the house bee.

During the times of food shortage or the dearth periods there will be no drones, as they are normally thrown out by the workers or left to die. If food shortage becomes severe and the food reserves in the colony deplete, the colony would abandon the existing nest-site and would migrate to other areas with better food availability. This process is called **absconding**.

1.4.2. **Communication in Honeybees: an essential requirement for successful colony life**

The ability of an animal to change or manipulate the behaviour of another animal of the same species is called **Communication**. A colony of insects which consists of several thousand individuals need an effective way to bring about proper coordination and integration of their activities or **Social Cohesion** and a proper balance between the individuals and the physical environment of their colony or **Social Homeostasis** (see Glossary, p.213). In a colony of insects, the activities that are essential for their survival, such as food gathering, food storage, reproduction, caring for the young, feeding, colony defence, cleaning, removal of the dead, air conditioning, air circulation, swarming and absconding are quite different to one another and hence honeybees have developed an effective way of communication for proper coordination of their activities. These communication methods could be categorized into two broad groups, such as,

- 1 Chemical Communication Signals
- 2 Physical Communication Signals.

1.4.2.1. **Chemical Communication Signals**

The social cohesion which is important in the functional integration of the colony is brought about by several chemical substances which are used in chemical communication and are called **pheromones**. These are produced by some glands in the bodies of workers and queen. Of these pheromones, the **queen substance** (mainly 9-oxo-2-decenoic acid or 9ODA) which is produced in the mandibular gland of the queen is a well-known queen pheromone. Two important functions of the queen substance is the maintenance of colony cohesion and suppression of the development of ovaries in workers (see Section 6.4). Due to the shortage in the supply of the queen substance, the social homeostasis could be severely disturbed and eventually the colony may become an **orphan colony** and such a situation is shown in Figure 1.10. Also it is well known in our honeybee, *Apis cerana*, that if the queen is removed even for a short period and is returned to the colony, the bees will soon start to peck her (**queen pecking**) and to ball her (**queen balling**) which eventually results in her death (see Section 7.4.2.). The intricate association or interaction between the queen and the workers could easily be seen in the formation called the "**queen court**" where a group of workers constantly antennate (touching each other with antenna), lick and feed the queen which forms a distinct circle of workers around her, is seen clearly in Figures 1.5 and 1.6. The formation of the queen court is very essential for the social homeostasis of the colony and the pheromones secreted by the **Tergite Glands** of the queen is essential for the court formation and stabilizing (see Figures 1.5 and 1.6). Therefore one should be careful in removing the queen from the colony.

The **Alarm pheromone** (mainly Isopentyl acetate) which initiates stinging behaviour is produced in the sting apparatus and the **orientation pheromone** (mainly citral, geraniol & nerol) produced by the Nasonov gland at the tip of the abdomen of the worker too are well-known worker pheromones (Figure 1.11). Pheromones play an important role in colony cohesion, mating, absconding, swarming, stinging and in many other behaviours important in social integration and survival¹.

1.4.2.2. Physical Communication Signals

The Greek naturalist and philosopher **Aristotle**, who lived in the 4th century BC was the first to realise the communication ability of honeybees. However the present clear understanding on the communication in honeybees is due to the intensive investigation of Professor **Karl von Frisch** (1886-1982) of Munich University in Germany between 1920 to 1950². Professor von Frisch was awarded the Nobel Prize for Medicine and Physiology in 1973 for his contribution to science in understanding the Honeybee Communication systems and the concepts he developed in Animal behaviour and Neuro - Physiology.

Among the physical communication signals of honeybees, the one that strikes us most and the one that seems a wonderful phenomenon in the animal world, is called the "**Bee Dance**". The simplest way to understand the effectiveness and efficiency in the communication ability of honeybees (either **Mee Bee**, **Bambara Bee** or **Danduwel Bee**) is to place a dish of honey in the open. Sometimes a honeybee worker may take a few hours or a few days to find this unusual source of food because they usually go to flowers to gather food. However if a single bee finds this dish of honey perhaps by accident it takes only a few minutes to mobilise hundreds of her nest mates to take the honey to their nest.

A **scout bee** who discovers a source of food on return to her nest will run among her nest mates in an excitement to draw their attention to her. Then she offers the food brought to a group of nest mates called **foraging bees**. During the process of food offering, the offering and the recipient bees mutually antennate each other and such two bees are shown in Figure 1.12. Foraging bees wait at the nest for the **scout bees** to bring clues or information about sources of food. Once the scout bee finishes offering the food she brought, then she starts to perform a distinct and rhythmic pattern of body movements which is called a "Bee Dance". This could easily be observed by us. In hive honeybees or Mee Bees depending on the distance between the nest (or the hive) and the food source three distinct patterns of body movements or three distinct types of dances can be observed.

These three types of dances are called,

¹Free, JB (1987) Pheromones of Social Bees, Chapman and Hall Ltd., London, UK. (ISBN 0 412 247402)

²Frisch, KV (1967) The Dance Language and Orientation of Bees. Harvard University Press, Cambridge, Mass., USA, xiv +566pp.

- 1** Round Dance - when the source of food is very close to the nest and the distance is less than 1 metre.
- 2** Sickle Dance - when the source of food is between 1-2 metres from the nest.
- 3** Tail Wagging Dance - when the source of food is more than 2 metres away from the nest.

1 Round Dance

After food offering, the pioneer scout bee will run in a circular path and this running circle or the round dance circuit will have a circumference of about the same as that of one hexagonal cell in a comb. While running in a circular circuit the dancing bee (or the scout bee) may change the direction of the run frequently and will run in the opposite direction. In this manner by running in a circular path and alternately changing the direction a scout bee is able to inform accurately the location of the food source to the **dance-following bees**.

It is not a problem for the scout bee to inform the exact location of a food source that was discovered in the day light on the horizontal ground by dancing on a vertical comb in the dark. Similarly the dance-following bees are able to interpret exactly what they were informed of in the dark in finding the food source in the open.

Honeybees have the ability to communicate the position of the sun with respect to the direction of gravity. When in open, honeybees locate the position of a food source with respect to its deviation from the constant line between their nest and the position of the sun.

Inside the dark nest on a vertical comb, the direction of gravity is considered as the constant line between their nest and the sun.

When running in a circular or a round circuit, the position where the direction of run is reversed is always a constant. The angle between the line of gravity passing through the centre of the round dance circuit and the line going through this centre and the point of changing direction is similar to the angle between hive to the sun and hive to the food source. Figure 1.13 illustrates the round dance and its interpretations.

The scout bees never perform the communication dance on empty combs or sparsely populated combs but on a place which is packed and fully covered with bees. The idea is to inform the maximum number of nest mates about her discovery. Depending on the profitability of the food source the intensity or the eagerness to perform the dance may vary. If the nectar source is more concentrated with a high quantity of sugar the eagerness to perform the dance or the dance intensity will be higher. Similarly if the nectar source is a dilute solution of sugar the number of dances will be less.

The smell of the food offered to the dance-following bees by the scout bee will also act as an olfactory clue for the easy detection of the new food source by the dance following bees who will go in search of it. Further the scout bee who returns to the food source will also liberate

the orientation pheromone by exposing her Nasonov's gland by lifting her abdomen and fanning her wings (such as shown in Figure 1.11). This further facilitates the new recruits to locate the food source easily. Therefore primarily a physical communication method and secondarily a chemical communication method is used in recruiting foraging bees to gather food by the pioneer who finds it.

Figure 1.13: The Bee Dance 1: The Round Dance and its Interpretation

- 1** A scout bee who returns to the nest after discovering a source of food less than 1 metre away from the nest communicates the information to her nest mates. A scout bee runs in a circular dance path and three **dance-following** bees follow her.

- 2** The point at which the scout bee changes the direction of the round dance path is kept constant through out the dance. This direction changing position gives a reliable clue to the direction in which the food source is located in relation to the direction of the sun. In the diagrams each consecutive dance is shown as an enlarged concentric dance path for clarity. However it should be remembered that all dances or circular runs are performed on a path with a constant radii and all points of changing the directions are nearly always at the same position on these circular paths.

Dance I: The position of the circular dance direction changing point when the food source is located in the same direction to the sun (towards sun). Here the direction changing point is directly opposite the gravitational directions (or the anti-gravitational direction).

Dance II: The position of the circular dance direction changing point when the food source is located at an inclination "b" in the direction to the sun. Here the direction changing point is kept at an angle "b" in the anti-clockwise direction from the centre of the dance circle and the anti-gravitational line passing through it.

(Therefore the honeybees dancing on a vertical plane seem to consider antigravitational direction as the direction of the sun on the horizontal surface of the earth. The angle of deviation between the direction from nest to the sun and from nest to the food source seems to be measured with respect to its inclination in an anticlockwise direction from the sun's direction, and as such from a corresponding anti-clockwise angle from the antigravitational line on the vertical dancing plane.)

Figure 1.13

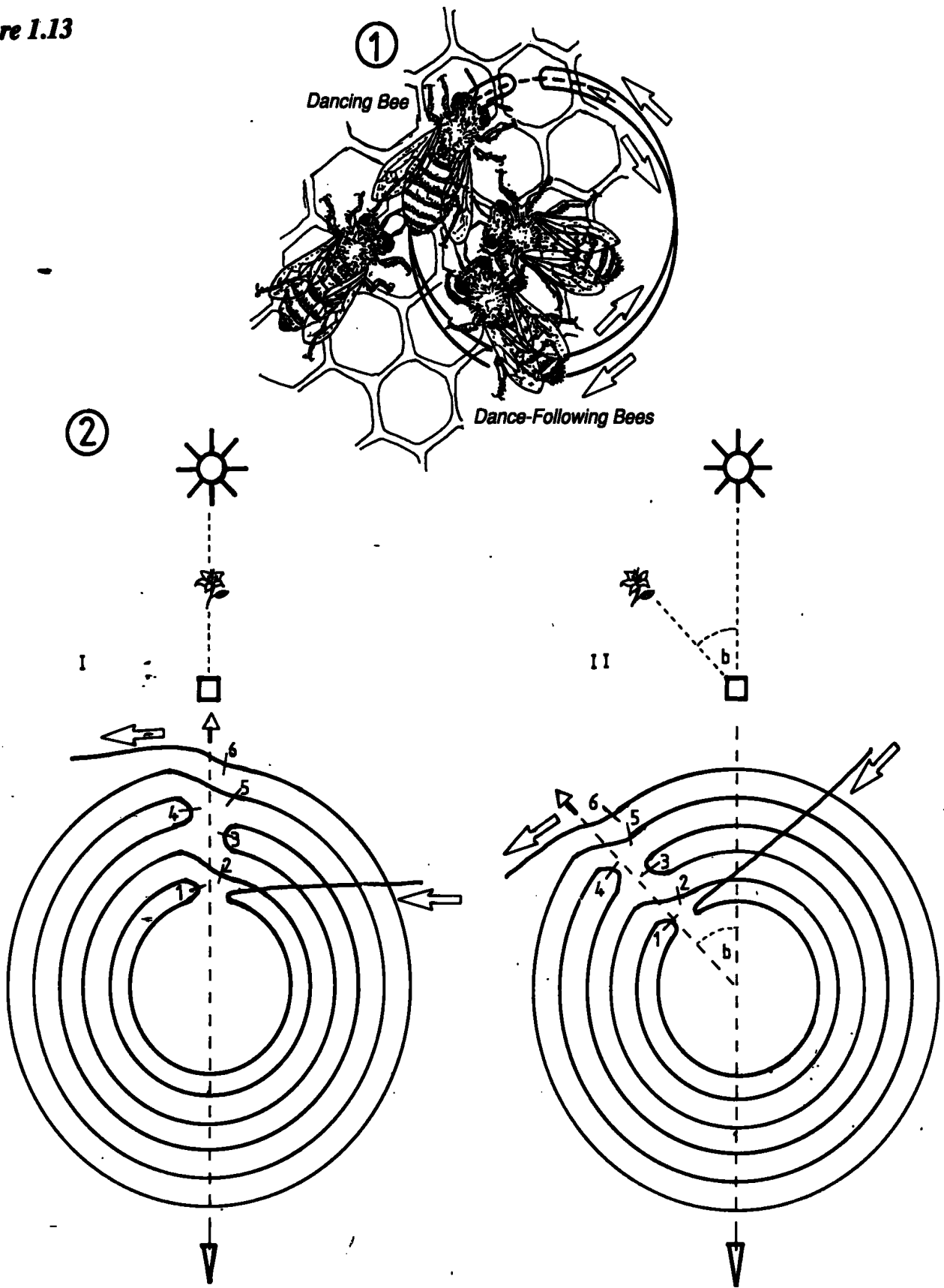

↑ The position of the change in direction of the dance path relative to the direction of gravity. This deviation from the vertical line indicates the direction on which the food source is located in relation to the straight line between the sun and the honeybees' nest

← The Entry to and Exit from the Dance Circuit

Figure 1.14

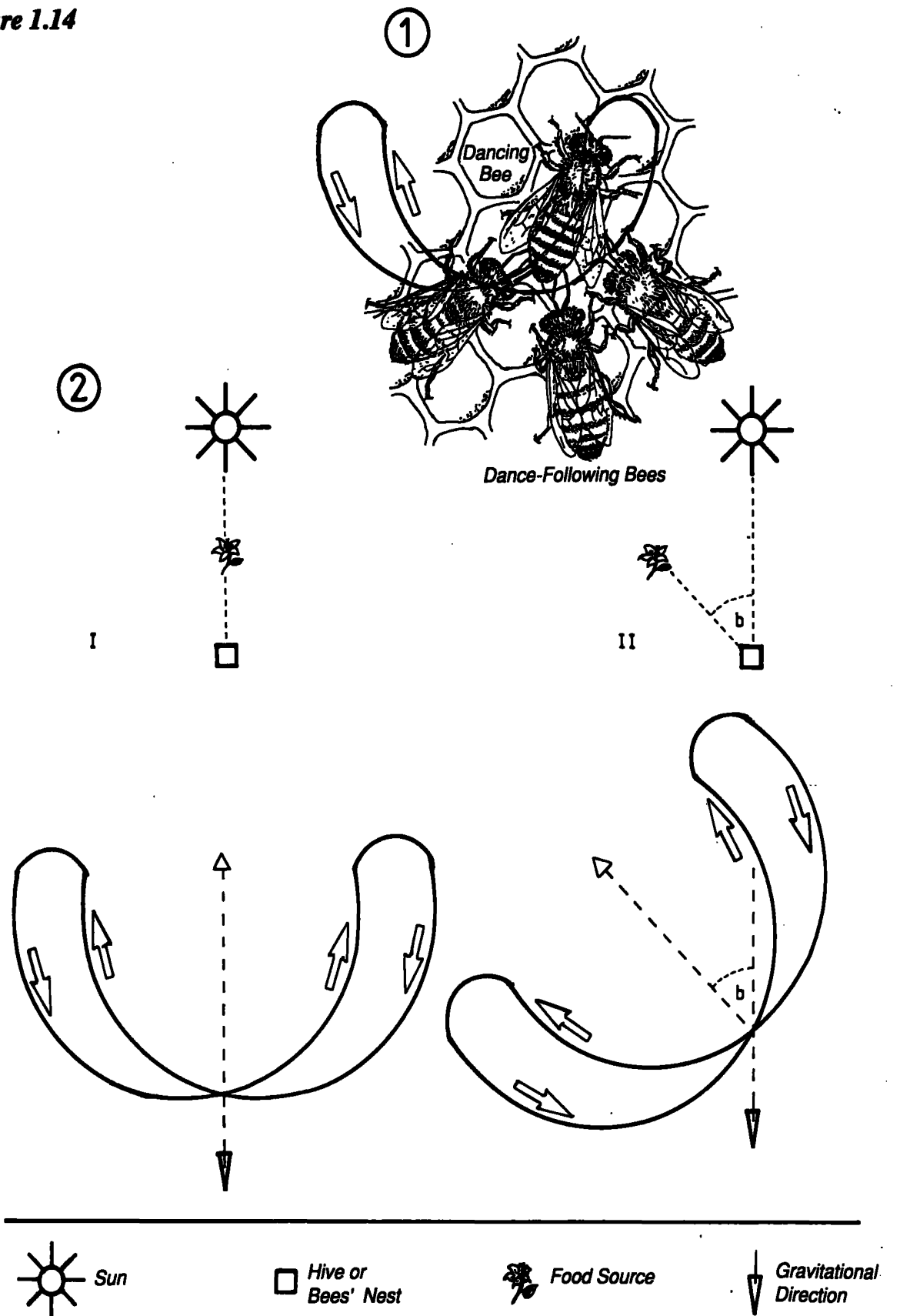

The direction of the open side of the Sickie dance path relative to the direction of gravity. This deviation from the vertical line indicates the direction on which the food source is located in relation to the straight line between the sun and the honeybees' nest

The directions of movement in Dance Circuit

2 Sickle Dance

When the distance to the food source is between 1 - 2 metres from the nest, the point at which the direction of the dance is reversed is kept as if the bee runs on an open circle or a sickle-shaped circuit. The angle between the line going through the middle of the open end of the sickle dance circuit and the centre of the circle and the gravitational line going through the centre of the circle indicates the direction of the food source relative to the position of the sun (see Figure 1.14).

Figure 1.14: The Bee Dance 2: The Sickle Dance and its Interpretation

- 1** A scout bee who returns to the nest after discovering a source of food more than 1 metre away but less than 2 metres from the nest communicate the information to her nest mates. A **scout bee** runs in a sickled shaped dance path and the **three dance-following bees** follow her.
- 2** The direction of the open end of the sickle dance circuit with respect to the location of the source of food.

Dance I: When the source of food is situated in the same direction to the sun.

Dance II: When the source of food is situated at an angle "b" from the direction of the nest to the sun, the open end of the sickle dance takes a "b" deviation in the anti-clockwise direction from the anti-gravitational line going through the centre of the sickle dance path.

3 Tail Wagging Dance

In the event of the bee discovering a source of food beyond 2 metres from the nest, on return to the nest after food-offering among her crowded nest mates she runs on a straight path shaking her abdomen (here we call this a tail wagging movement). After performing the abdomen shaking or tail wagging run on a straight path for a definite period of time lasting for a few seconds she returns to the starting point on a semi-circular path (see Figure 1.15). The dance tempo or the tail wagging frequency of the straight tail wagging run and its inclination to the direction of gravity gives accurate information about the distance and the direction of the location of the food source from the nest. It could easily be observed that the dance tempo or the tail wagging frequency increases as the distance to food source decreases (or the dance tempo is inversely proportional to the distance) and the time spent on each straight waggle run to increase as the distance increases (dance time is directly proportional to the distance). Figure 1.16 illustrates the relationship between the time taken per complete waggle dance and the distance to the food source from an experiment conducted to determine the maximum and

average foraging distances of the local honeybee³. According to this study it could be inferred that the maximum foraging range of our local honeybee to be about 600 metres and the average foraging range to be about 300 metres. The practical implications of the short foraging range is discussed in detail in section 2.3 and in Chapter 7.

For foraging honeybees it is not essential to see the sun directly to determine the sun's relative positions during the day. They are able to determine the sun's relative position only by seeing **plain polarized light**. Honeybees are sensitive to plain polarized light which is usually reflected from the blue sky. Depending on the position of the sun during the day the light pattern of the polarized light changes and these changes are well observed by the honeybees through their eyes which are sensitive to this kind of light. Similarly Mee Bees and

Figure 1.15: The Bee Dance 3: The Tail-Wagging Dance and its Interpretation

- 1** A scout bee who returns to the nest after discovering a source of food more than 2 metres away from the nest communicating the information to her nest mates. A **scout bee** runs on a straight tail-wagging dance path and the three **dance-following bees** follow her.
- 2** The direction of the tail-wagging run depending on the location of the food source with respect to the constant line from the nest to the sun. The solid arrow indicating the direction of the straight tail wagging run.

Dance I: When the source of food is situated in the same direction to the sun from the nest the scout bee will run straight upwards (Antigravitational direction). A directly opposite situation is shown in Dance V.

Dances II, III & IV:

When the source of food is situated on to the left side in the direction from the nest to the sun, the scout bee will perform the straight tail wagging run with corresponding angle to the anticlockwise direction from the antigravitational line.

Dance V: When the source of food is in the opposite direction to the direction from the nest to the sun, the scout bee will perform the straight tail wagging run towards the gravitational direction. A directly opposite situation as shown in Dance I.

Dance VI: When the source of food is situated on to the right side in the direction from the hive to the sun, the scout bee will perform the straight tail wagging run with a corresponding angle from the antigravitational line a situation directly opposite to dance IV.

³Punchihewa, RWK; Koeniger, N; Kevan, PG & Gadawski, R (1985) Observations on the dance communication and natural foraging ranges of *Apis cerana*, *Apis dorsata* and *Apis florea* in Sri Lanka. J. of Apicultural Research 24 (3) : 168-175.

Figure 1.15

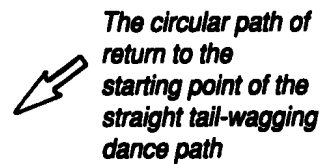
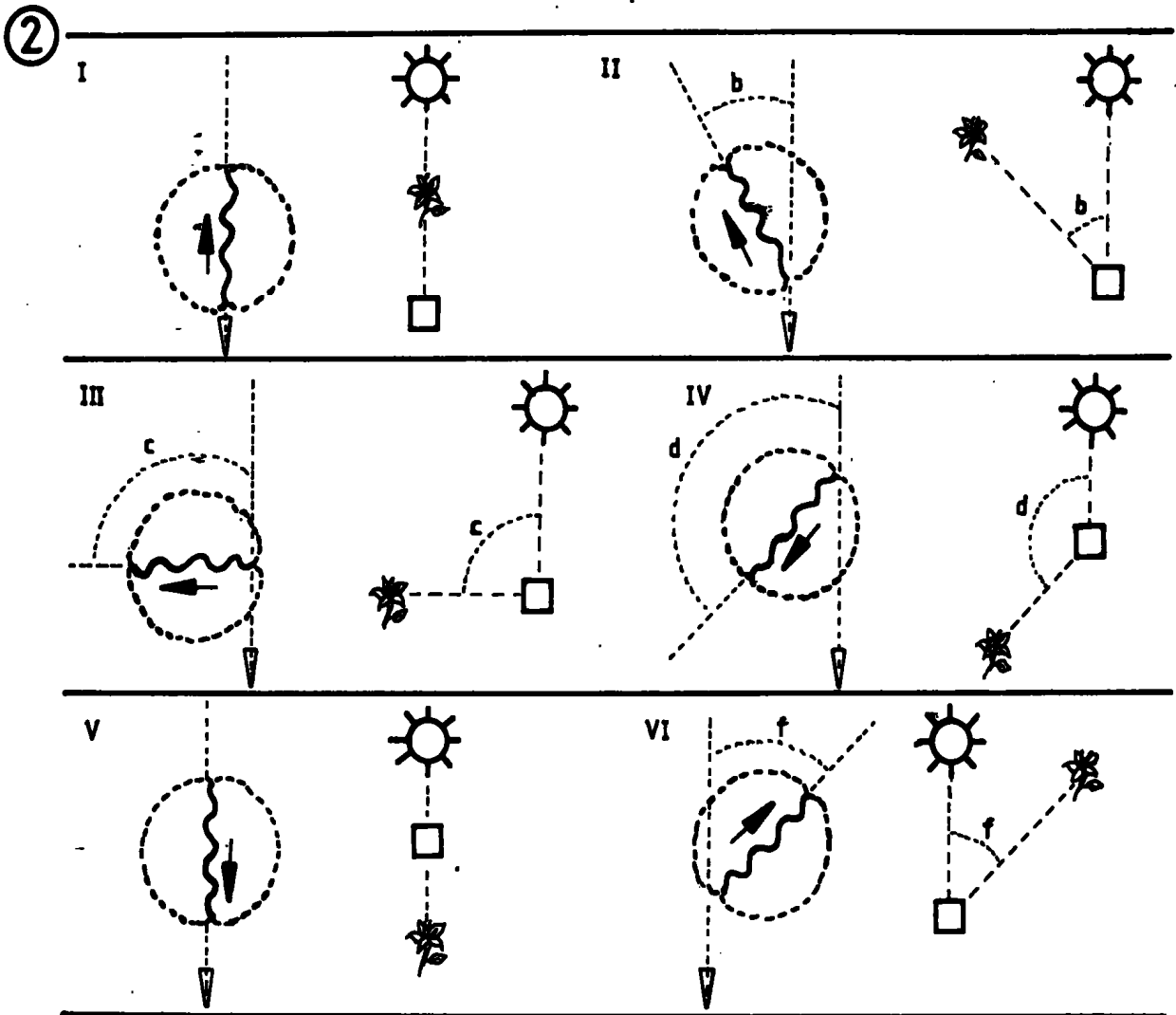
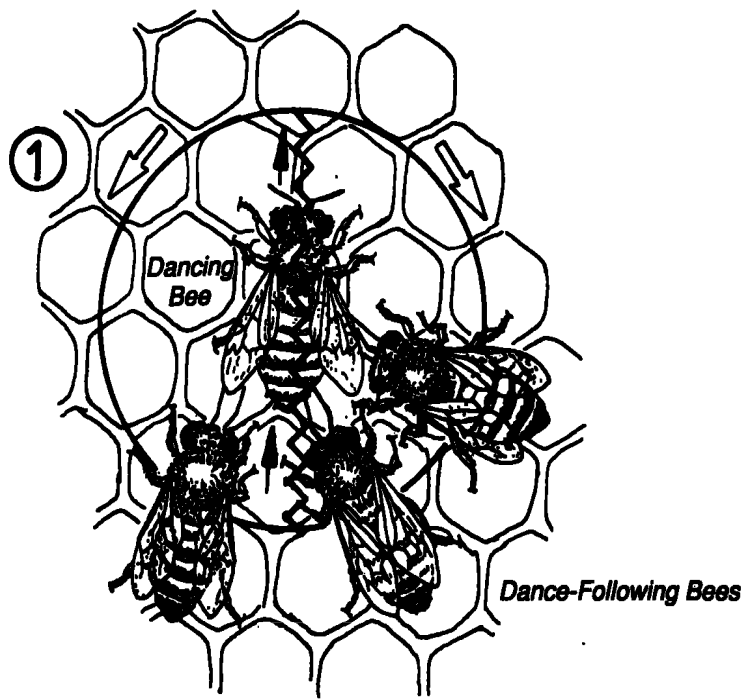

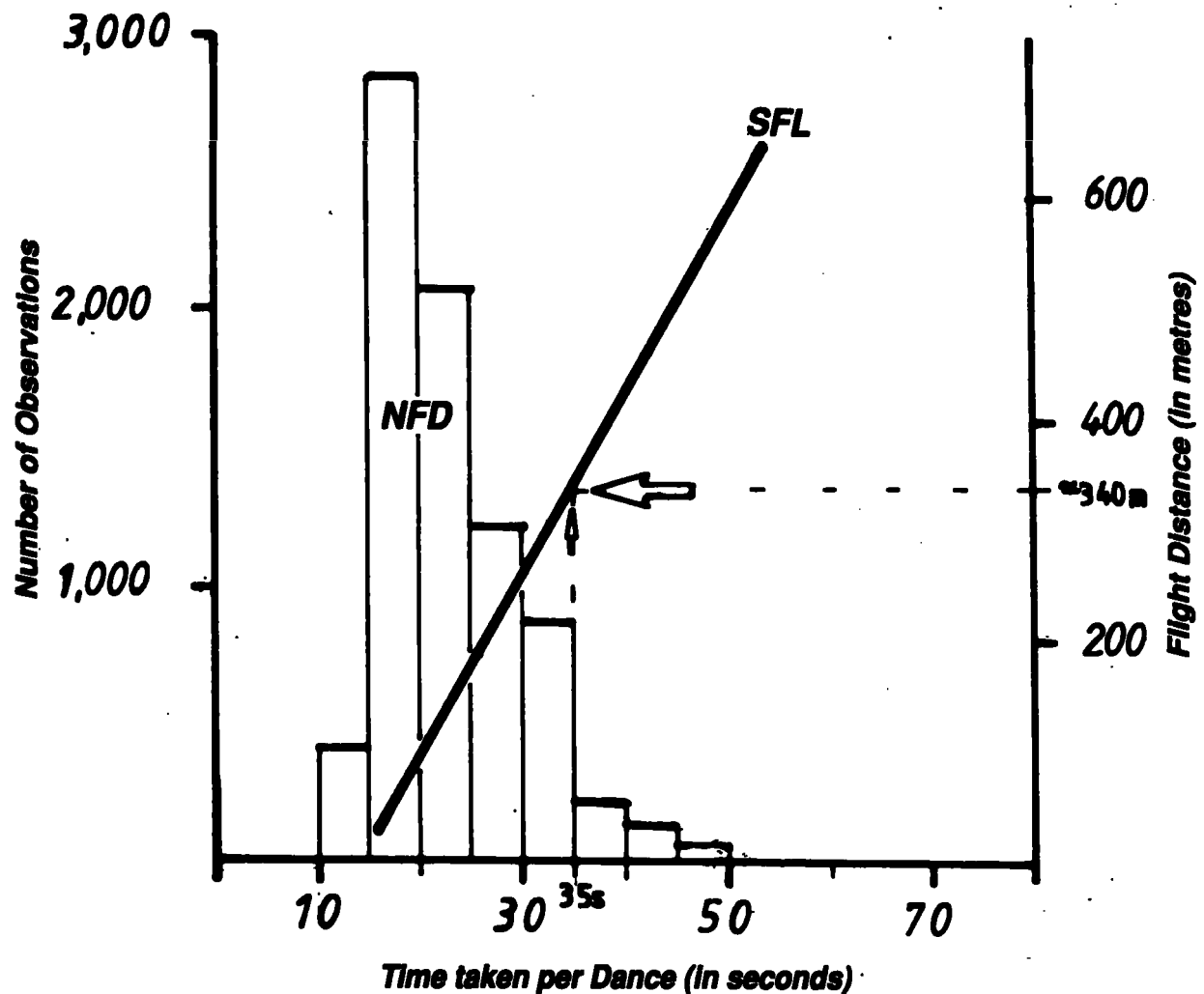

The Natural Foraging Dance (NFD) periods are arranged in 5 second time intervals

The Standard Flight Line (SFL) indicate the relationship between time taken per tail wagging dance and the distance that a bee would travel to collect food.

Figure 1.16: Application of the information transmitted by foraging bees during Tail Wagging dances for a practical beekeeping problem

- ★ The line graph indicates the relationship between the dance tempo and the distance travelled to the food source. The Standard Flight Line (SFL) indicates that the distance to the source of food is directly proportional to the time taken per dance. This graph was constructed by observing and measuring the time taken (in Seconds) to perform the tail wagging dances by the bees who visited to collect food from an artificial source of food kept at a known distances (in Metres) from the observation hive.
- ★ The bar graph constructed by observing thousands tail wagging dances performed by bees foraging on naturally occurring sources of food indicate that majority of the forages have performed dances lasting less than 35 Seconds. These natural foraging dances (NFD) indicate that the majority of bees foraged within 340 Metres radius from the nest.

Bambara Bees are able to determine the direction of gravity. Therefore Mee Bees and Bambara Bees are able to perform the communication dance on a vertical comb and inform their nest mates of the location of a food source in relation to sun's position by using the direction of gravity to represent the constant line between the sun and the nest. Mee Bees who are considered to be at a more advanced stage in evolution have the ability to memorize the position of the sun and then to transpose the direction of the sun inside its dark nest by using the direction of the gravity.

Bambara Bees do not perform the communication dance in a dark nest. Therefore the Bambara Bees see the blue sky or the sun from a vertical comb where it performs the communication dance. However, the ability of the Bambara Bees to forage in the night is now clearly evident. Especially during the nights with moon light Bambara Bees forage well, the mechanism of this ability is not understood yet.

Danduwel Bee constructs its honey nest around the twig of a tree from which the brood nest is suspended and the upper part of the honey nest provides a suitable dancing platform for this purpose. Danduwel Bee nest is exposed from all sides and the top portion of the honey nest provides a horizontal dancing platform by making it possible for the dancing bees and dance-following bees to observe the sun or the blue sky directly. Further clues from surrounding help in orientation of the dancing bee.

Mee Bee need not to see the sun or the blue sky at all to perform the communication dance. Therefore this capability has provided the Mee Bee with the ability to construct its nest which consists of several parallel combs in a well-protected, enclosed and dark nest site. Due to this Man is able to rear Mee Bee successfully in an enclosed container or a hive. In this respect Asiatic hive honeybees (*Apis cerana* and *Apis koschevnikovi*) and European and African hive honeybee (*Apis mellifera*) behave very similarly.

Even though the bee dance is described here as a way of communicating the information about a food source, it is not confined only to gathering food. Somewhat modified dance communication systems are employed by honeybees in Swarming and Absconding where the activities of thousands of individuals are involved in these processes and therefore they have to be effectively coordinated.

In honeybees, there are several body organs sensitive to gravity and one pair is located on either side of the body region that connects the head to the thorax or the neck while the others are located on either side of the body region that connects the thorax to the abdomen or the **propodium** or the thin waist.

A student of Professor von Frisch, Professor **Martin Lindauer** should be credited as the first to describe the communicating dances of Asiatic honeybees when he conducted many experiments in Sri Lanka between 1954 to 1955⁴.

⁴Lindauer, M (1956) Über die Verständigung bei indischen Bienen, Zeitschrift für vergleichende Physiologie 38 : 521-557.

Lindauer, M (1957) Communication among the honeybees and stingless bees in India, Bee World 38 : 3 - 14 & 34 - 39.

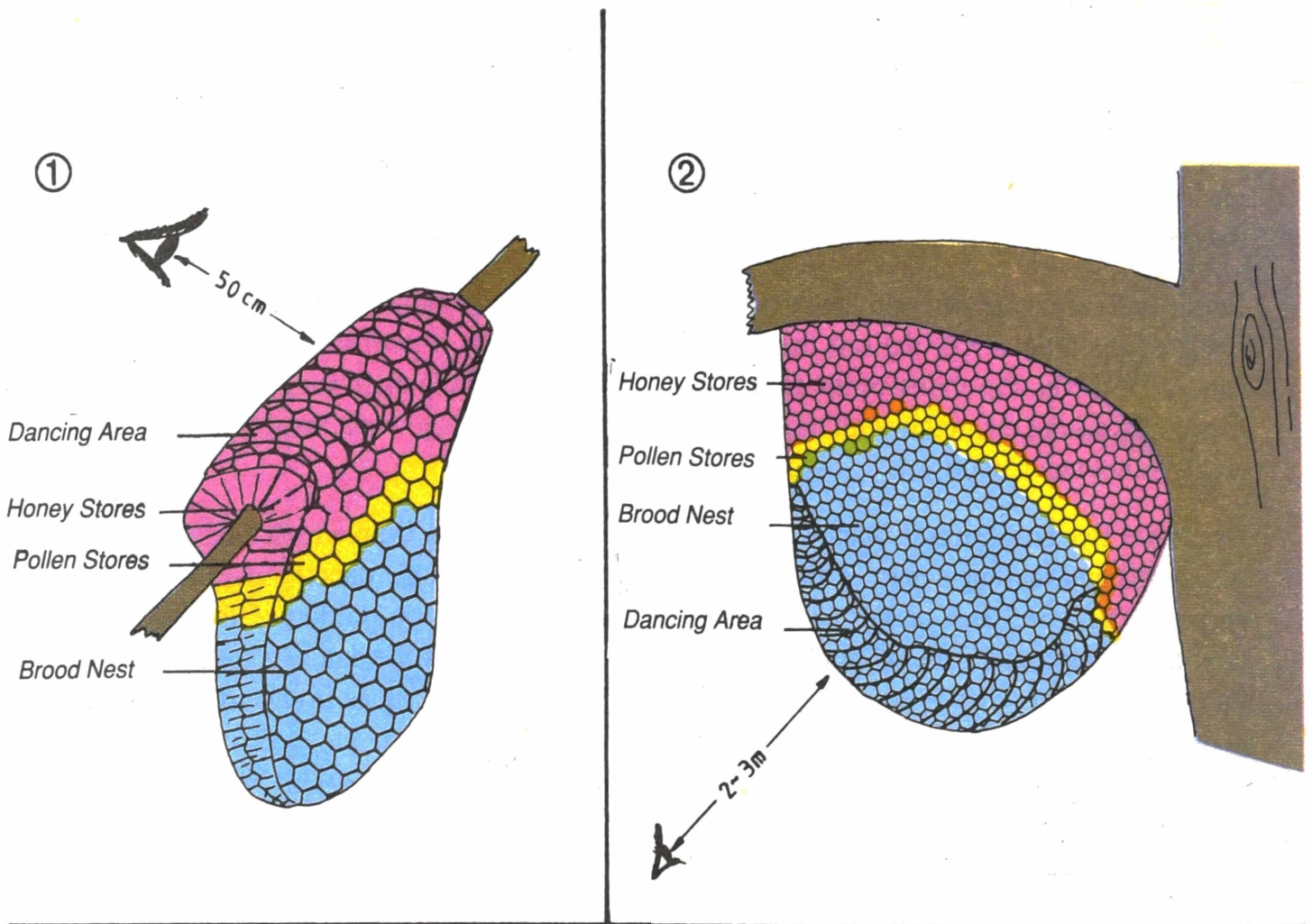

Figure 1.17: Two occasions where bee dance could easily be observed ^{3,4 & 5*}.

- 1 Danduwel Bee (*A. florea*) performs her communicating dance on top of the honey comb area of her nest using it as a horizontal dance platform. Hatched area indicates the dancing area.
- 2 Bambara Bee (*A. dorsata*) performs her communication dance on the brood comb area of her nest using it as a vertical dance platform. Hatched area indicates the dancing area.

***IMPORTANT WARNING:**

When observing the natural foraging dances of Danduwel Bee or Bambara Bee one should be extremely careful not to disturb the bees. If agitated the bees would attack. Especially the attacks of Bambara Bees can be very dangerous. Undisturbed colonies could be easily observed.

⁵Koeniger, N; Koeniger, G; PUNCHIHEWA, RWK; Fabritius, Mo & Fabritius, Mi (1982) Observations and experiments on dance communication in *Apis florea* in Sri Lanka. J. of Apicultural Research 21 (1): 45-52.

1.4.2.3. The Nest Architecture of Honeybees Determined by the Physical Communication Ability

The easiest way to observe the bee dance is by watching a nest of Danduwel Bees or Bambara Bees on a clear sunny day during the morning hours. Then one is able to see the pollen carrying bees performing the tail wagging dance with pollen loads intact. Danduwel Bees perform the dance on top of its single combed nest using it as the horizontal dance platform (see Figure 1.17 - 1). Bambara Bees perform the dance on the peripheral parts of its single combed nest using it as the vertical dance platform (see Figure 1.17 - 2).

Therefore for these reasons a Danduwel Bees nest has to be exposed from the top (see Figure 1.3) so as the dancing bees and the dance-following bees that observe the sun or the blue sky from a horizontal dancing platform. Similarly-Bambara Bees (see Figure 1.2) should be able to see the sun or the blue sky from a vertical dance platform. Mee Bees who have evolved into a more advanced species perform the communicating dance inside its dark nest and under normal circumstances we are unable to observe this. To observe the dances of the Mee Bee they have to be kept inside a special observation hive constructed for this purpose.

Considering the above facts it becomes clear that the communicating ability on the location of the sun has become the prime reason for Danduwel Bee nests to be fully exposed, and Bambara Bee nests to be exposed only on two sides but covered from the top while Mee Bee nests to be completely enclosed.

Therefore we can consider,

- 1 Danduwel Bee (*Apis florea*)
and
Bambara Bee (*Apis dorsata*) - as open nesting honeybees,
- 2 Mee Bee (*Apis cerana*) - as enclosed nesting honeybees.

For this reason Mee Bees who are able to perform the communication dance in the dark can construct their nest inside an enclosed container or a hive and they can construct several parallel combs in their nest (see Figure 1.1). The Danduwel Bees and Bambara Bees who are unable to perform the communication dance in the dark are also unable to construct a nest in an enclosed space and can build only an exposed single comb (see Figures 1.3 & 1.2). Comparative nest architecture of stinging honeybees are diagrammatically represented in Figure 4.1 (page 58).

1.4.2.4. Energy Conservation by Means of the Bee Dance

During a day the many species of plants that flower may be scattered in the environment and the time of secretion of nectar of these flowers may also vary. To locate such nectar-secreting flowers during a particular time period many individual bees from a colony have to be mobilized. Then only a few will succeed in finding profitable sources of nectar and therefore considerable amounts of food energy would go waste for the bees who do not find food sources.

However the honeybees who have reached an advanced evolutionary stage among insects will not indulge in such wasteful exercises. Instead of mobilizing a large work-force to locate food sources, they would utilize a specialized group of a few individuals (here we call them the "Scout Bees") initially to discover and then to report the presence of food in the environment. Once the scout bees inform the location and profitability of the food sources in the environment then a large number of workers are mobilized to gather the discovered food and to bring it quickly to the nest, which is a more profitable way of labour utilization.

A scout bee will dance only if it gets enough nectar to fill its honey stomach, but when it does not, the dancing stops. Such a feedback mechanism helps to utilize the foraging bees efficiently.

Therefore, the "Bee Dance" that we humans tend to interpret as a dance from our perspective is actually a "Honeybee Communication Centre" where one individual communicates useful information to hundreds of others in its nest. This communication centre helps to conserve energy and use the scarce energy in the most efficient manner.

1.4.2.5. Bee Hissing: another communication method in Mee Bees

It could be observed that if one goes near a honeybees nest and makes a slight disturbance, the bees will liberate a rhythmic sound which we can call a "Hissing".

This hissing may be a deterrent to prevent any predator approaching the nest. The whole colony participates in the hissing behaviour and it would easily be seen that to generate the hissing sound the bees make a particular rhythmic body movement which travel like a distinct wave through the bees covering the nest. It has been observed that Mee Bees tend to be less aggressive after making the hissing sounds⁶. Therefore, it would be more appropriate if beekeepers open their hives and smoke them for examination only after bees give out the hissing sound on approaching the hive. The use of smoke on Mee Bees are discussed in section 1.5.3.1. and in Chapter 8.

⁶Koeniger, N & Fuchs, S (1973) Sound production as colony defence in *Apis cerana*, Proc. 7th IUSSI, London. p. 199-204.

1.4.3. Stages of Life and Activities of Three Types of Colony Members

The following is a short account of some of the major functions and differences between the queen, drones and workers. Like all insects, bees too have two stages in life called the juvenile and the mature. In the case of bees, after hatching from an egg laid in a waxen cell, the juvenile stage is spent in the same waxen cell. At this stage the appearance is like a grub or a worm. It is called the **larval stage**. After growing for a few days as a larva, it enters a **pupal stage** where it stops feeding and goes into a deep sleep for a few more days. During the pupal stage, some drastic changes take place and the grub-like larva transforms into a winged individual with many distinct differences in the body. These changes are called **metamorphosis**.

Table 1.2. Juvenile stages and flight activities of colony members.

Colony Member	Egg stage (days)	Larval stage in open cells (days)	Pupal stage in sealed cells (days)	Duration between emergence to first flight (days)	Life-span
Queen ¹	3	4 - 5	6 - 7	4 - 7	Several years
Drone ²	3	5 - 6	14 - 15	7 - 10	6 to 8 weeks
Worker ³	3	5	12	5 - 7	4 to 6 weeks

¹**Queen.** There is only one queen in a normal colony and she is always present. She goes on a single mating flight (occasionally two mating flights) to a special site in the air among tree canopies called **Drone Congregation Areas (DCA)**. This flight lasts for about 10 minutes and takes place between 15:30 hours to 17:00 hours. In a DCA, all the mature flying drones in the vicinity will assemble in flight for the arrival of a mate-seeking queen. A queen would mate with about 7 - 8 drones at a DCA while in flight to receive about 7 - 8 million sperms but she would retain only about a million sperms in her **spermatheca** (the organ that store sperms) for future use. Once successfully mated (see Figure 10.4), she will not leave the hive unless for swarming or absconding and her main task will be to lay eggs. A virgin queen weighing about 110mg at the time of emergence will gain in weight to about 160mg in 3-4 weeks times when she starts to lay eggs properly. A queen in a fully grown colony would lay between 350 to 700 eggs per day depending on the season. Each slightly curved-rod-shaped egg measures about 1.8mm in length and 0.4mm in diameter and weigh about (or a little less than) 0.2mg and therefore, during the active breeding season a queen can lay an amount of eggs weighing nearly her own body weight per day, which seems a marvel. Genetically the queen and

workers are similar and are born out of fertilized eggs (therefore called diploid). But the special food supplied by the nurse-bees throughout the larval period makes the queen develop her reproductive organs to be fully functional once she is grown up. This special food is called "**royal jelly**" and is produced in the **hypopharyngeal glands** of young worker bees, who do not fly out of the hive till they are about 7 days old. Queen larva is fed with copious amounts of royal jelly and she virtually floats on a blob of this whitish substance. The juvenile stages of the queen is spent in a special cell called the **queen-cell** which is about 16 mm long and about 7 mm in diameter in the middle and is slightly spindle-shaped. The queen cells are constructed at the bottom end of combs and are vertical. The queen has a sting but she will use it only against another queen.

² Drone. The appearance of drones are seasonal and if food supply becomes lean the workers will eliminate drones. A drone is produced from an unfertilized egg (therefore called haploid) laid in a hexagonal cell larger than a worker cell. During the season several hundreds are present. Normally the drones are produced before the production of new queens during the onset of a **honey flow**. Drone combs or combs containing juvenile drones are somewhat larger hexagonal cells compared to worker cells, measuring about 5 mm in diameter and 13 mm in height too, constructed in the lower regions of combs and horizontal. One hundred drone cells cover an area between 18.5 cm² to 20.5 cm². The sealed drone cell has a distinct hole in the middle of the capping which appears in about 2 days after being capped (see Figure 6.4, p. 126). Mature drones perform the mating flight daily between 15:00 hours to 17:30 hours as long as they are present in colonies⁷. During the drone flight period, mature flying drones assemble in a particular space in the sky among canopies of trees and this is called a **Drone Congregation Area (DCA)** (see Figure 10.3). These flying drones will return to the nest for short pauses during the drone flight period for food. A drone could mate only once with a queen and the successful drone dies afterwards. The most important and the only function of the drones are to fertilize young queens. A single drone weighing about 85mg produces about a million sperms and good part of the abdomen cavity contains the reproductive organs. The drone has no sting neither will it bite if caught and has no defence.

³ Worker. Normally several thousands are always present and during abundance of food more are produced. A worker is produced from a fertilized egg laid in a hexagonal cell which is about 4 mm in diameter and 10 mm in height. One hundred worker cells cover an area between 13.5 cm² to 15.0 cm². The food supplied to worker larvae is called "**bee milk**" and is different from royal jelly. Flight activity can take place through out the day-light period and the foraging activity starts at dawn by about 05:45 hours and lasts till about 18:15 hours at dusk. Though the workers would fly any time of the day, normally only about 10% of the workers are actively engaged in foraging. During a honey-flow period, this can be higher. Workers attend to all the duties in a colony such as foraging, food processing and storage, attending and nursing the young, comb building, cleaning, guarding against intruders, incubating the brood, air-conditioning, water carrying, feeding the queen and drones, decision-making in raising drones or queens, absconding, swarming and regulating colony size etc.

⁷Koeniger, N & Wijayagunasekara, HNP (1976) Time of drone flight in the three Asiatic honeybee species, J. of Apicultural Research 15(2): 67-71.

The ovaries of the workers are normally reduced in size and inactive. The duties assigned to workers depend on their age and usually young workers attend to **in-house** duties while older ones go **foraging**. A worker weighing about 65mg can carry about 25mg of nectar and can fly at the speed of 22-25 km per hour. On the pollen basket of its hind legs pollen pellets weighing about 10mg can be carried from flowers to the nest. The worker has a well developed sting and always uses this in defence. Once the worker uses its sting it gets detached and lodged in the victim's flesh. The detachment of the sting leaves a wound that causes the worker's death, a few hours later.

1.4.4. Division of Labour and Functional Specialization Among Female Members of the Colony

As it was mentioned in page 1, the honeybee colonies are sometimes referred to as "**Super organisms**". That is, any insect society such as a colony of honeybees, possessing features of an organisation analogous (or having similar function but differing in origin and structure) to the physiological properties of a single organism (or an organ). As such quite clearly the individuals in a honeybee colony can be divided into reproductives and worker castes (or a group of individuals which perform a special function in the economy of the colony with appropriate morphological, physiological and behavioural adaptations acquired for that purpose). The reproductive castes are analogous to gonads or reproductive organs and worker castes analogous to somatic tissue or the other body organs performing other functions and so forth. As much as reproductive organs and other body organs cannot function on their own the different castes of social insects also cannot function independent of each other.

One of the effective ways of understanding the super-organism status of a colony of honeybees is by inquiring into the performance of specialized tasks by the female members of the colony. The honeybee queen and the workers who inherit an identical genetic composition differ greatly in their morphological appearance. The queen honeybee or the fertile female and the workers or the sterile females differ from each other in over 50 morphological features. Correspondingly there are similar numbers of physiological and behavioural differences among these two types of females or castes.

When considering a honeybee colony as a whole it is biologically advantageous to have several thousands of workers and therefore the colony remains perennial. However, when a single worker is considered, her life-span is relatively short and she lives only for a few weeks. Therefore if a colony with a large number of members are to be perpetual, a large number of workers has to be constantly reproduced to take place of the continuously dying ones. This necessitates the queen acquiring very high reproductive capacity and as such she is relatively large in body size and has a large abdomen containing well developed reproductive organs. The workers whose reproductive organs are diminutive have a smaller body size. The queen honeybee is highly specialized in egg production and does not take part in the other activities of the colony. As such she possesses no appendages or ability for food gathering and even her mouth parts are reduced to some extent, which compels the workers to feed her. Therefore, the honeybee queen has specialized as a reproductive individual and workers have specialized as non-reproductive individuals who have to perform all other functions essential in the survival of the colony.

Table 1.3: A Brief Outline of the Age-Determined-Polytheism and Division of Labour in the Honeybee Workers or the Sterile Females.

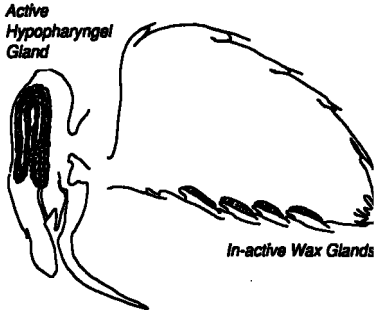
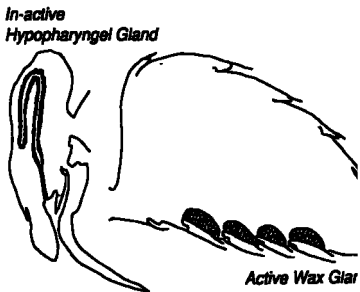
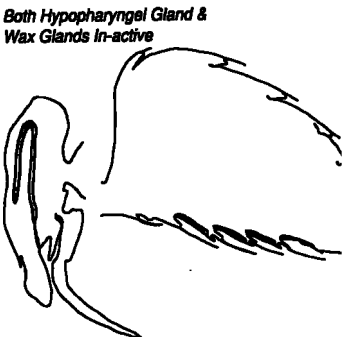
Age of the adult worker in Days	Place of activity depending on the functional need	Nature of specialized behaviour depending on the functional need	Morphological adaptations for specialized behaviour				
			Head	Abdomen			
1	House bees attend to in-house duties within the nest.	Cleaning bees Cleaning the brood cells		<i>Active Hypopharyngeal Gland</i> <i>In-active Wax Glands</i>			
2							
4							
5		Court bees feeding the queen and receiving queen substances					
6							
7							
8		Nurse bees feeding and attending the young					
9							
10							
11		Comb-building bees building new combs			Air-conditioning bees maintain the air circulation and nest temperature		<i>In-active Hypopharyngeal Gland</i> <i>Active Wax Gland</i>
12							
13							
14							
15							
16							
17							
18	Guard bees protecting the nest from intruders						
19							
20							
21	Dance following bees receiving information						
22							
23							
24	Field bees spend most of their functional duties out-side the nest.	Foraging bees - Scout bees - Nectar bees - Pollen bees - Water carrying bees Finding sources of food. informing the others of there locations and food gathering		<i>Both Hypopharyngeal Gland & Wax Glands In-active</i>			
25							
26							
27							
28							
29							
30							
31							
Till Death							

The existence of morphologically (structure and form of an organism) different types of individuals in a colony and their functional specialization or the division of labour is called **polymorphism or caste differentiation** in biology.

The non-reproductive functions which are also essential for the survival of a honeybee colony are highly varied and some degree of specialization is essential in performing them successfully. For example food gathering, building of wax combs, nursing the young, cleaning the cells for egg laying, defence of the colony etc. are all indispensable and distinctly different activities essential for survival. A honeybee colony accomplishes these requirements successfully by mobilizing several groups of workers specialized in each of these important activities. The undertaking of different activities are determined by the age of the workers and to some extent the existing requirements or priorities of the colony may also influence the number of workers in each task group. The phenomenon of individuals of different ages undertaking different specialized activities is called **age-determined-polyethism** in biology. Some of the essential features of **age-determined-polyethism** and division of labour in a honeybee colony is summarized in Table 1.3.

A good example of the honeybee workers who perform an **altruistic act or self-destructive behaviour** for the benefit of the others is attacking the intruders to her colony. Once a "guard bee" attacks and stings the intruder, the sting apparatus gets dislodged from her body and this causes death in a-while. For this **altruistic behaviour** a honeybee workers possesses morphological adaptations such as a venomous sting and pheromones to trigger defence attacks. It is also important to realize that this altruistic behaviour is not only confined to defending the nest but for the same reason the honeybee workers have given-up raising her own off-spring for the sake of helping her mother to raise her sisters. As such she becomes a sterile worker rather than a fertile queen.

Therefore, it becomes clear that the altruistic behaviour has greatly facilitated not only increasing the efficiency in the division of labour among non-reproductive castes or the workers but it has also influenced the efficiency of the reproductive castes or the honeybee queens by making her virtually an egg laying machine whereby she is capable of laying several hundred eggs per day whose weight may match her own body weight.

1.5. Some Distinctive Characteristics of Honeybees

Bees are a group of insects specialized to live on flowers. The main economic value of honeybees are due to their ability to collect and store nectar from flowers. In nature, bees derive their nutrition entirely from flowers. They do so in two ways. First, the sugars in flower nectar serve as the source of energy-generating or carbohydrate food and there may be small quantities of minerals and vitamins in it. Second, the pollen serves as the source of proteins or body-building food (mainly for brood rearing) and also to provide essential vitamins, minerals and fats. Thus flowers provide all the nutrients required by the bees.

Flowering plants that co-evolved with bees also obtain many benefits from them. One of the very important aspects of this is the pollination carried out by bees on their part. Without proper pollination, plants are unable to produce seeds which are essential for their survival.

Therefore flowering plants and bees have a very close relationship which is important for the survival of both. But for convenience, here we shall be concerned only with what is pertinent to honeybees and their management.

Biologically the three different types of individuals, namely the queen, the drones and the workers are equally important in a honeybee colony. However, in beekeeping we pay more emphasis on workers as they are directly involved in visiting flowers, gathering nectar and making honey. Therefore, in the following sections we consider some of the distinctive characteristics of honeybee workers, displayed by them in deriving sustenance from flowers.

1.5.1. Adaptations to Live on Flowers: pollen collection and storage (Figures 1.18 & 1.19 illustrate various body parts)

The body of a worker honeybee is densely covered with branched hairs where pollen grains easily lodge. Un-branched hairs occur on the compound eye and the legs. On the foreleg, the tibia is margined by an eye-brush of stiff hairs or bristles for cleaning the compound eyes, and the distal end bears a flat movable spine, or tibula. The latter closes over a bristle-lined notch on the proximal end of the tarsus to form an antenna comb, through which the antenna is drawn to remove pollen grain and other foreign material. Long hairs on the large first segment of the tarsus form a cylindrical pollen brush to gather pollen from the fore-parts of the body. On the middle leg, the first tarsus also has a pollen brush to remove pollen from the fore-legs and body; and the inner distal end of the tibia bears a spur used in picking up wax scales from the wax-glands situated underneath the abdomen. On the hind leg, the wide tibia is slightly concave externally, margined by a row of curved hairs to form a pollen basket (corbicula). This has a comb of stiff hairs, the pecten, at its distal end, and just below is a flat plate, or the auricle. The outer surface has a pollen brush for cleaning the body posteriorly, and its inner surface carries about 10 rows of stiff downward pointing spines forming a pollen comb.

When pollen is gathered from a flower, it is taken by the mandibles, moistened with nectar, and mixed with the pollen that gathered on the pollen brushes of the forelegs (a pollen collecting bee is shown in Figure 2.2). It is then moved to the brushes on the middle legs, which in turn are drawn between the pollen combs of the hind tarsi. The hind tarsi are then scraped over the opposite leg to deposit pollen on the pecten or outer surface of the auricle. By flexing the tarsus on the tibia, the pollen is pushed upwards and packed into the pollen basket. The bee thus accumulates a bulging load of sticky pollen in both baskets. On return to the hive it pushes its load into a cell to be pressed down by the heads of young workers.

The smooth mandibles of workers serve to packing pollen, to mould wax for making combs and in many other functions such as cleaning etc., (see Figures 7.5-7.8, p.159).

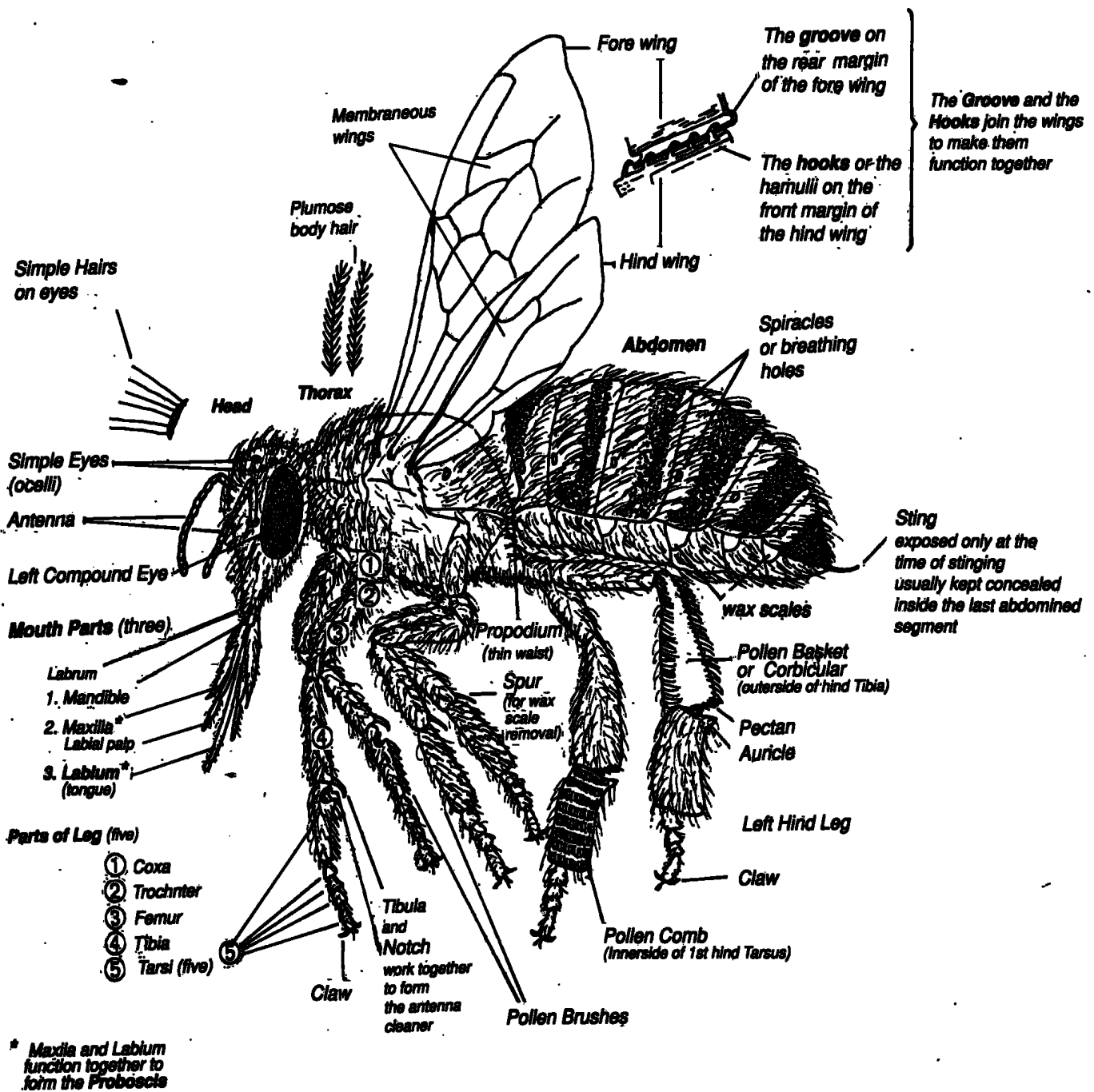
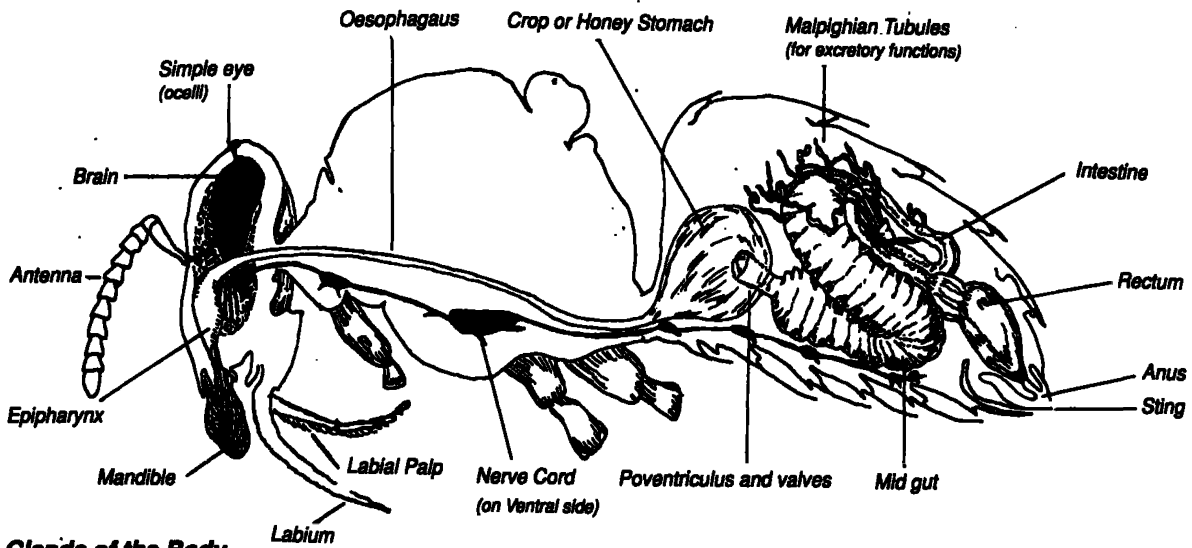
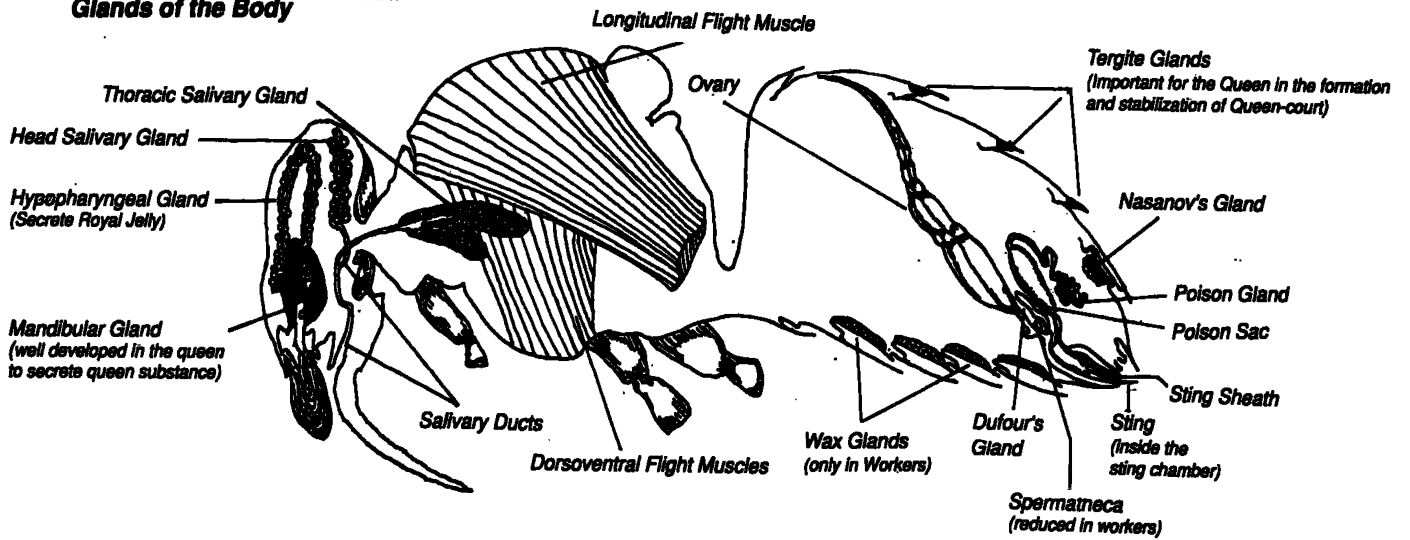

Figure 1.18: Details of some of the important external structures and appendages of honeybee workers.

Allimentary Canal & Nerve Cord



Glands of the Body



Sting Apparatus

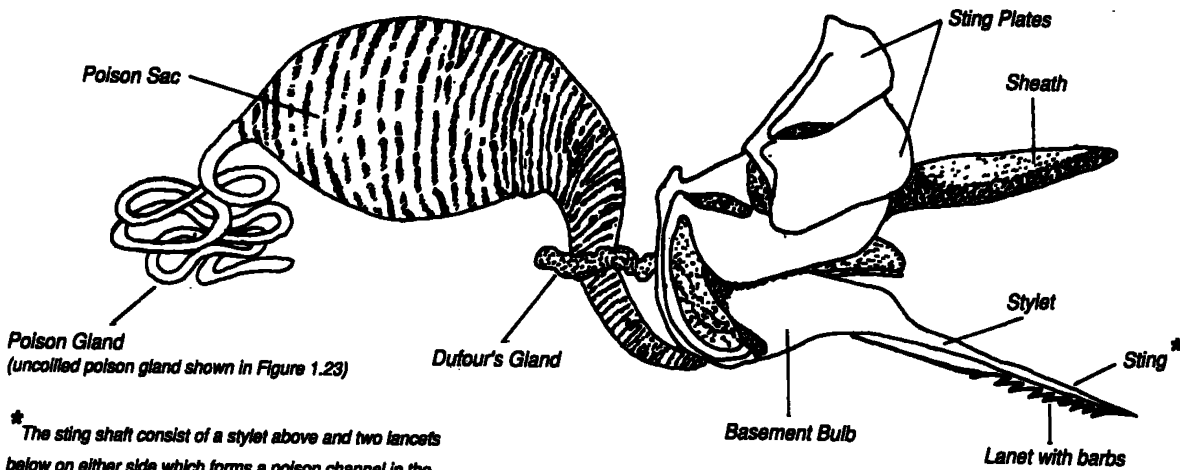

* The sting shaft consist of a stylet above and two lancets below on either side which forms a poison channel in the middle.

Figure 1.19: Details of some of the important internal structures and appendages of honeybee worker and queen.

At rest, the thin delicate wings lie flat over the back. In flight the two wings on each side are locked together by a row of fine hooks situated at the front margin of the hind wing that catch onto a groove along the rear margin of the forewing. The wing may vibrate up to 300 times per second and can fly up to 750 metres from the nest on foraging. But in general the Sri Lankan honeybee does not forage beyond 300 metres.

1.5.2. Adaptations to Live on Flowers: nectar collection and honey making (Figures 1.18 & 1.19 illustrate various body parts)

The maxillae and labial palps form a tube around the slender tongue or labium. Due to the movement of the tongue and pumping action of the pharynx, fluid nectar is drawn into the large crop or honey stomach (a nectar collecting bee is shown in Figure 2.1). Behind the honey stomach are four triangular lips that form a valve to prevent nectar or honey from entering the stomach except when the bee is in need of food.

The slender intestine is joined by about 100 malpighian tubules which serve the same purpose as the kidneys of vertebrate animals. The large rectum serves to accumulate faeces for discharge through the anus after a bee leaves the hive.

Nectar held in the honey stomach is acted upon by salivary enzymes to convert the complex sugars such as sucrose (cane sugar, a di-saccharide) into simple sugars such as glucose and fructose (mono-saccharides). Upon returning to the hive, the worker regurgitates to give this sugary fluid through her mouth parts to a **house-bee** (a young non-foraging bee) through a process called "liquid transfer" (Figure 1.12). The young "house bees" would repeatedly work it over in their mouths, causing further chemical changes. The nectar now converted to honey would be deposited in cells. The house-bees evaporate the excess water by fanning with their wings and then seal the cells with wax. Generally honey should have less than 20% water for long storage.

Among the other function of workers, fanning (Figure 1.20) to ventilate the nest and guarding (Figure 1.21) to prevent any intruders are also important

1.5.3. Some Features Important in Beekeeping

1.5.3.1. Stinging and Smoking

As we all know, one of the unpleasant factors in handling honeybees is that they can sting, an experience which is painful. As we discussed earlier, this is a mechanism found in honeybees which is utilized in defending themselves and common among other members of the order Hymenoptera such as wasps and ants.

The sting is a modified ovipositor, present only in workers and queens (female members). Therefore the drones (the male bees) cannot sting. Due to the rough upwardly pointed spines

on either side of the stinging dart, it gets hooked in the tissue of the victim (Figures 1.19 & 1.22). Due to the action of muscles of the sting apparatus, the detached sting will further penetrate deep into the muscles of the victim. For a few minutes after being stung, one can easily observe the palpitating sting that tries to penetrate deep. The poison sack attached to the sting apparatus now hooked to the victim sends poison through the dart. Due to this poison the human muscles swell after being stung and produce pain.

One should not try to use fingers to remove the stings, whenever stung, as it tends to squeeze the poison further in. A better method is to scrape the sting (Figure 1.23) away with a sharp edge such as that of a knife. Therefore many beekeepers keep a small knife in the vicinity when examining hives.

Smoke has a retarding effect on bees by helping to reduce their eagerness to sting in defence. Smoke is commonly used by beekeepers to subdue bees when they are examining and manipulating hives. The reason for this subdued behaviour on the part of the bees is not fully understood, although it may relate to a primitive instinct to prepare for flight from forest fire. When smoke is blown over a colony, workers react to it and begin to feed themselves with honey. Bees whose stomachs are full of honey are much easier to handle, being less irascible. One should remember that smoking causes some disturbances to the colony and therefore it should be done carefully. Over-smoking may have detrimental effects and the smoke itself should be mild such as is produced from burning coconut husk.

With the proper use of a smoker one can greatly reduce the unpleasant experience of getting stung and a smoker is one of the essential appliances of modern beekeeping. The use of a smoker is discussed else where (see Chapter 8).

1.5.3.2 Memory, Learning Ability and Changing Hive Position

Bees have a remarkable ability to remember and learn things when compared to other insects. This characteristic too is important in practical beekeeping, especially when the beekeeper intends to shift the location of his hives. Relocation of hives has to be done with care if one is to prevent the loss of thousands of worker bees. As a rule the hives should be shifted in the night when all the foraging bees are inside.

It is also very important to make the bees understand that their nest site or the hive position has been changed and the beekeeper should take them through a re-orientation process at the new hive site. This is done in the following way. In the evening when all the bees have returned to the hive, the entrance should be closed and the entrance plate or the entrance guard could be used for this purpose or one can use any suitable plug to close the entrance. Once it is moved to the new site, the entrance should remain closed and there should not be any other exit ports such as cracks in the hive body. What is important is that, for a while the bees should not be allowed to fly at the new site. Instead, the roof should be removed at dawn to expose the crown board or the inner-cover where many bees would come to the mesh placed over the ventilation holes. In fact one can easily see many bees biting the mesh in their struggle to

escape from the hive. Keep the bees trapped at least for about half an hour and this creates confusion among the bees. It is important not to keep the hive in hot sun but in a shady place where rays of sunlight fall on the ventilation holes.

Once the bees are struggling to fly out and they are kept prevented from getting out for about half an hour or so, one should now open the inner-cover (Figure 1.24) allowing them to come out from the top. The bees should not be allowed to come from the regular entrance at the beginning. The bees rushing out through the opened top will not try to go on foraging but instead they would fly around the hive getting an orientation to the new location. Bees should be allowed to fly out from the top for about 15 minutes before one opens the regular entrance.

The honeybees in a hive should not be kept closed for longer periods (more than an hour) in the day light. The light that the bees see through various apertures in the hive makes the foraging bees to struggle to fly out. This causes their death due to exhaustion by attempting to fly, if kept closed for longer periods.

Bees use land marks such as trees, buildings, rocks, roadways, etc., just as much as we humans do to remember places. If the bees were allowed to go out from the normal entrance at the new hive location the foragers who are going out would leave the hive without knowing that their hive position had been changed and they will not be able to come back. If the hive was shifted only a few hundred metres (less than 600 metres) and no process of re-orientation was carried out by the beekeeper, one can see hundreds of bees gathering at the former hive location (see Figure 1.25). If the hive was to be taken back to the former site, the gathered bees would rush in instantly. In an experiment where the ability of the bees to return to the original hive location was examined and it was found that when the hive was shifted 700 metres away from the original site none of the bees were able to come back to the original site. This indicated that the bees entered an unfamiliar terrain at this distance and this finding indirectly confirmed the short natural flight range of our bees (see Figure 1.16).

If the hives are to be shifted more than one kilometre, the bees will not be able to find their way back to the former hive site. There is no harm in opening the normal entrance after changing the hive position by more than 1km. The bees recognize the news surrounding and will re-orientate themselves. The foragers who take their orientation clues before going on their foraging flights will be able to come back.



Figure 1.20: A fanning bee at the hive entrance sends air currents inside. Such fanning bees are a common sight at the hive entrance during warm afternoons.



Figure 1.21: A bee guarding the hive entrance. Note that fore legs are folded up in ready mode for attack when necessary. Compare with the fore legs of the bee behind and the fanning bee in Figure 1.20.



Figure 1.22: A stinging bee.

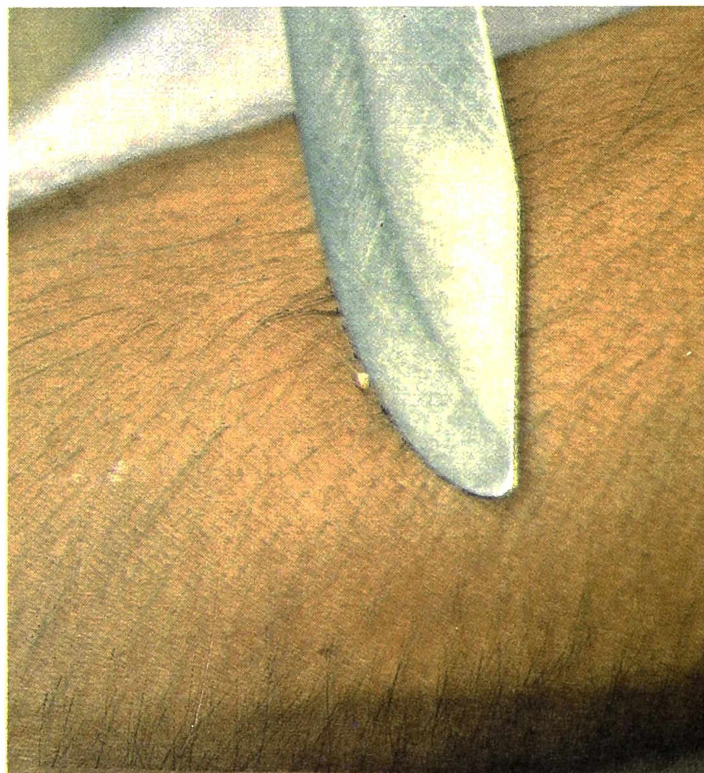

Figure 1.23: Removal of the detached sting by scraping it away with the sharp edge. Here the entire sting apparatus with the poison sack is hooked to the victims flesh and what appears like a thin thread in the uncoiled poison gland (see Figure 1.19).



Figure 1.24: If the hive is taken to a new place, first open the hive from the top for the bees to escape. Note the entrance is blocked with the entrance guard. The many bees who have come to the ventilation holes in the inner-cover are seen at the top.



Figure 1.25: Flying bees would return to the original location of their hive even when the hive was moved a short distance. The hive in the background was moved 2 metres away from its original position now occupied by the floor-board on a stand. Returning bees tend to gather at the floor-board kept at the original site rather than going to the hive just 2 metres away.

Honeybees of Asia: a prologue

By

Prof. Dr. Nikolaus Koeniger and Dr. (Mrs.) Gudrun Koeniger,
Institut für Bienenkunde,
Fachbereich Biologie der J. W. Goethe-Universität-Frankfurt am Main,
Germany.

The true honeybees of the genus *Apis* are a very "old" and a prominent group of highly social insects. The separation of the ancestral *Apis* from other *Apini* apparently happened several million years ago and the scenario of the origin is still under debate among researchers and scientists. But the location where this has happened certainly was in South East Asia. Here are found six of the seven honeybee species existing today and only one *Apis mellifera*, occurs naturally in the Near East, Africa and Europe.

With the scientific and industrial development during the last 100 years in Europe and North America (where this bee was introduced by European immigrants) the European *Apis mellifera* became a major subject of research and soon became one of the "best studied" insects. As a consequence beekeeping and honey production methods made rapid progress, and European *Apis mellifera* soon became the dominating source of the world's honey supply.

The Asian tradition took advantage of the high biodiversity of the native honeybee species. Elaborate and effective honey hunting methods evolved and allowed the harvest of substantial honey stores of the giant honeybee *Apis laboriosa* nesting in steep rocks of the Himalayas. The nests of the defensive *Apis dorsata* in the canopy of the highest trees of the Asian rain forest were successfully exploited and yielded large quantities of natural forest honey until modern times. But also the small honeybee species *Apis florea* and *Apis andreniformis* are regularly harvested, and their honeys play a major role in the preparation of traditional medicine.

The Asian hive honeybee *Apis cerana* is also target of honey hunters who rob their colonies during the harvesting season wherever they can find them. But this played a special role regionally. Since ancient times people have hung broken pots, placed hollow tree trunks in their fields and gardens or even left cavities in the walls of their houses to provide nesting sites for *Apis cerana*. Thus the traditional form of honey hunting to an initial stage of beekeeping actually took place in Sri Lanka as well as in many other Asian countries. However, the further development towards a more effective and economic honey production met with several major difficulties.

First of all *Apis cerana* was generally considered a miniature and a more primitive form of *Apis mellifera*, and Western beekeeping methods were applied without much success. The *Apis cerana* colonies responded to the inadequate treatment with extensive swarming and absconding. The honey production was low and did not balance the considerable costs of hives and labour involved with Western beekeeping. Similar experiences in many parts of tropical Asia earned *Apis cerana* the false reputation of being a "poor" honey producer and a honeybee of a low economic value. Therefore the importation of the Western *Apis mellifera* for local honey production took place in many countries in Asia. Most of these introductions failed. The imported Western honeybees fell prey to a variety of predators like birds, hornets and parasites. In Northern India, China and several other Asian countries, however, the establishment of *Apis mellifera* succeeded, and beekeepers are able to produce large amounts of honey keeping these exotic honeybees.

But these "success stories" do have a few undesirable side effects. The imported bee colonies disrupted the natural balance among the native Asian honeybees species and especially *Apis cerana* became extinct in areas with intensive *Apis mellifera* beekeeping. Further the inevitable exchange of parasites and diseases among the exotic and local honeybees causes drastic damage on both sides. For example, *Apis mellifera* has no effective defence against parasitic Asian honeybee mites *Tropilaelaps clareae* and *Varroa jacobsoni*, which are effectively controlled by their natural host species *Apis cerana* and *Apis dorsata* but rapidly multiply in *Apis mellifera* colonies causing heavy losses and the break down of the colony. In consequence, beekeepers interfere and regularly treat their colonies. The application of medications (acaricides) is a common practice in Asian *Apis mellifera* beekeeping and may cause hazardous chemical contamination of honey and other bee products.

During recent years the importance of the great and exciting biodiversity of tropical habitats was recognized and more global environmental research has started. The diversity of the Asian honeybees gained increasing international attention and quite a number of comparative behavioural and physiological research data became available. As a main point we can summarize that *Apis cerana* is not at all a small and primitive form of the Western *Apis mellifera*. This Asian hive honeybee is a real species on its own with several complex and highly developed behavioural characteristics which in colony defence and natural resistance against parasites surpass the standards of the European *Apis mellifera*.

Dr. Punchihewa took an active role in covering some of the research difficulties of Asian honeybees. Consequently he began to realize the biological requirements and needs of *Apis cerana*. His beekeeping concepts became more and more independent from Western ideas and developed into a general understanding of *Apis cerana*. His innovative approach of cooperation and symbiosis between the local honeybee and the Sri Lankan beekeeper resulted in practical beekeeping procedures. Swarming and Absconding problems find convincing solutions which help to increase the honey yields as well as "the happiness" of the honeybees. Altogether Dr. Punchihewa demonstrates the high economic potential of *Apis cerana* as a honey producing bee in Sri Lanka, at the same time his honeybee colonies remain a natural element of the local fauna. The beekeeper has to respect the natural environment and should

not resort to any kind of destructive measures or treatments like killing birds, hornets or mites. The honey gained from such activities surely is a pure natural product, and the pollination provided by the bees plays a vital role in the conservation of local flowering plants.

Dr. Punchihewa's book explains the biological fundamentals of honeybee biology and give concise and practical instructions for beekeeping in Sri Lanka. Surely this concept of *Apis cerana* beekeeping will prove valid also in other countries of tropical Asia where Coconut and Rubber is grown. But to us the importance of Dr. Punchihewa's book stretches far beyond this. It gives a fine example of income generating agricultural activity which is beneficial to environmental conservation. We hope that this concept will be expanded to further parts of the continent and to other Asian honeybee species: "keeping the local honeybees for honey production and conservation must gain more momentum ! "

2. Principles of Beekeeping

2.1. The Essential Prerequisites

Beekeeping is an industry that has a very high dependence on the environment. In general many agricultural pursuits have a dependence on the environment but its effect on beekeeping is much more intense.

The most important feature of beekeeping is honey production and its success is determined by four complementary factors:

- 1 The availability of nectar and pollen in the environment. **Honey Flow or the Environmental Potential.**
- 2 The nectar and pollen sources are within the foraging range of bees in the vicinity. **Foraging Range.**
- 3 Existence of a sufficient population of honeybees to collect the nectar in the environment effectively. **Potential of the Population of Honeybees.**
- 4 Climatic conditions that are important in realizing the nectar potential of the environment and foraging potential of a population of honeybees. **Climatic Potential.**

All these four factors have to operate at an optimum level and even if one factor is limiting, that would be a great hindrance for profitable beekeeping.

Of these four factors, the beekeeper will not have any control over the fourth factor. However, with a better understanding of the first and the second factors, a suitable site for profitable beekeeping could be selected. The third factor is under the complete control of the beekeeper and his main role would be to maintain an optimum population of honeybees as required.

Therefore the beekeeper has the chance to control two factors of the above four complementary factors. Thus the selection of a site where there is a honey-flow to rear honeybees and then to get an optimum population size as necessary are the main responsibilities of the beekeeper. What is important in effective management of a bee population is the colony volume or the nest size.

In this regard, the ability of the beekeeper to get an optimum population of bees becomes the critical issue. This ability could only be gained with the proper understanding of the bees and taking timely action according to their requirements.

2.2. Environmental Conditions

2.2.1. Climatic Conditions

Sri Lanka has a wide variety of climatic conditions. Each climatic area has its distinctive natural and agricultural vegetation types and consequent diverse potential for honey production. For nectar production a sufficient rainfall is necessary and for nectar collection a dry weather becomes imperative.

Depending on the monsoonal rainfall distribution there exist a dry season which has broadly divided the climate of the island into three major climatic zone (see Table 2.1 and Figure 10.5 p. 208).

Table 2.1: Major Climatic Zones of Sri Lanka

Climatic Zone	Dry Season
Dry	Distinct (about 6 ~ 7 months from February to March and May to September)
Intermediate	Moderate (about 4 ~ 5 months from May to September)
Wet	Slight (about 2 months from February to March)

However when other important eco-geographical factors such as natural vegetation, agricultural land use, annual rainfall (1250 ~ 5000mm), elevation (0 ~ 2500m), temperature (10° ~ 32° C), topography, soil etc., were collectively considered it is possible to identify 24 distinct agro-eco-climatological regions in the island¹.

In spite of this wide variation in eco-climatic conditions, all four species of honeybees are found to exist naturally in all three major climatic zones. However, only *Apis florea* is found naturally in the Northern peninsular region (Jaffna district) and only *A. cerana* and *A. dorsata* are found naturally in elevations over 1,000 metres (Nuwara Eliya district and mountainous parts of Badulla, Ratnapura, Kandy and Matale districts).

As far as Mee Bees are concerned, a colony of bees will have to maintain a precise temperature (about 34°C) and relative humidity (about 70%) within the brood-nest for effective brood-rearing. Alterations of these optimum conditions by disturbance, over heating in the sun, exposure to heavy monsoonal winds and rain, etc. will cause extra work and stress to the bees and may lead to lowering of the production and eventual absconding.

Therefore when one considers weather conditions suitable for beekeeping, it is a matter of the macro-climate of the area concerned and micro-climate of the nest site of the honey bees as well.

¹Panabokke, CR (1994) Personal Communications and from the forthcoming book "Soil Landscapes and Agro-Ecological Environments of Sri Lanka".

2.2.2. Bee Forage: nectar and pollen sources

The natural forests in all climatic zones, which has a mixed population of many different plant species which flower almost throughout the year (see Table 2.2), holds the highest potential for honey-production. In such environments, honey-hunting is a common phenomenon that takes place from time immemorial to date².

When considering cultivated areas, **Rubber** (*Hevea brasiliensis*: Euphobiaceae) growing regions and **Red Gum** or River Red Gum (*Eucalyptus robusta*: Myrtaceae) planted areas in the Uva Province can contribute to successful honey production. Though there are some fruit species which are good sources of nectar, due to their scattered and scanty distribution the value in honey production is limited. **Coconut** (*Cocos nucifera*: Palmae) is a reliable and year round source of pollen but not a good source of nectar.

In the dry zone forest, there are several honey-flow periods due to the presence of many plants of which several are given in Table 2.2.

Even though there may be many other good nectar-producing plants in the dry zone forest, their distribution and density is low and thus value in beekeeping may be unknown. Even those mentioned in Table 2.2 do not exist in sufficient numbers in many accessible areas and therefore the honey yields are low.

Of the cultivated species, the following plants are good nectar producers. These plants are used as shade trees and in soil conservation.

- Albizzia** - *Albizzia lebbek*: Leguminosae,
- Gliricidia** - *Gliricidia sepium*: Leguminosae and
- Calliandra** - *Calliandra calothyrsis*: Leguminosae, which seems to be a better plant as this flowers practically through out the year.

If honeybee colonies could be taken to the **Tala** or **Gingilly** (*Sesamum indicum*: Pedaliaceae) fields during the flowering periods in the dry zone, good yields could be produced (see Figure 10.1 p.195).

Coffee (*Coffea arabica*: Rubiaceae), **Rambutan** (*Nephelium lappaceum*: Sapindaceae), **Cashew** (*Anacardium occidentale*: Anacardiaceae) are all visited by bees for nectar but of minor importance because these are not widely grown.

Among the ornamentals **Kaha Mara** (*Peltophorum pterocarpum*: Leguminosae) a large shade tree, **Wedelia** (*Wedelia biflora*: Compositae) a good ground cover, and **Antigonon** or **Coral vine** (*Antigonon leptopus*: Polygonaceae) an ornamental creeper are all useful for bees in providing nectar.

² **Of Honeybees and Honey Hunting** (see page. xii-xiii)

Baker, SW (1855) Eight Years in Ceylon. 1966 reprint. Tisara Prakasakayo Ltd, Dehiwela, Sri Lanka.

Knox, R (1681) An Historical Relation of the Island Ceylon. 1966 reprint. Tisara Prakasakayo Ltd, Dehiwela, Sri Lanka.

It is highly desirable to plant species that are useful for bees as well as for other purposes and not to destroy the existing bee forage and the forest. For successful beekeeping it is imperative to have a successful environmental conservation programme and it is reiterated that Beekeeping and environmental conservation are two activities that can complement each other. Figures 2.1 to Figure 2.11 show various plants that can produce honey and the range of flowers the bees forage.

Table 2.2: Some of the Plants in the Dry Zone that Can produce a Considerable Amount of Nectar ³

Common Name	Botanical Name: Plant Family	Flowering or HoneyFlow Period
Weera	<i>Drypetes sepiaria</i> : Euphobiaceae	January - February
Palu	<i>Manilkara hexandra</i> : Sapotaceae	February - March
Mora	<i>Nephelium longana</i> : Sapindaceae	March - April
Kirikon	<i>Walsura pisida</i> : Meliaceae	March - April
Divul	<i>Feronia limonia</i> : Rutaceae	March - April
Kon	<i>Schleichera oleosa</i> : Sapindaceae	March - April
Kohomba*	<i>Azadirachta indica</i> : Meliaceae	March - April
Burutha	<i>Chloroxylon swietenia</i> : Rutaceae	March - April
Siyambala*	<i>Tamarindus indica</i> : Leguminoceae	April - May
Kumbuk*	<i>Terminalia arjuna</i> : Combretaceae	May - June
Maha Dhang	<i>Syzygium cumini</i> : Myrtaceae	June - July
Mi	<i>Madhuca longifolia</i> : Sapotaceae	June - July
Kala Wel or Bo Kalawel	<i>Derris scandens & D. uliginosa</i> : Leguminoceae	August - September

(*planted as road side shade trees in some areas)

³Baptist, BA & Punchihewa, RWK (1980) A Preliminary analysis of the principal factors which will affect apiary honey production in Sri Lanka. Proc. of the 2nd International Conference on "Apiculture in Tropical Climates". Indian Council of Agricultural Research, New Delhi and International Bee Research Assoc., London, pp 87-99.

Fernando, EFW (1979) The ecology of honey production in Sri Lanka in "Beekeeping in Rural Development", Commonwealth Secretariat and International Bee Research Asso., London, pp 115-125, 191 & 192.



Figure 2.1: A honeybee foraging on a large and showy **Zinnia** (*Zinnia elegance*: Compositae). The bee is sucking nectar with the extend proboscis from a floret.



Figure 2.2: A honeybee foraging on a tiny and inconspicuous **grass flower** (*Bracheria brizantha*: Graminae). The bee is hovering and packing pollen while collecting more from the anthers.



Figure 2.3: **Antigonon** (*Antigonon Leptopus*: Polygonaceae) creeper growing on a garden fence. Antigonon flowers through out the year, grow easily and are useful honeybee forage plants that can enhance natural beauty.

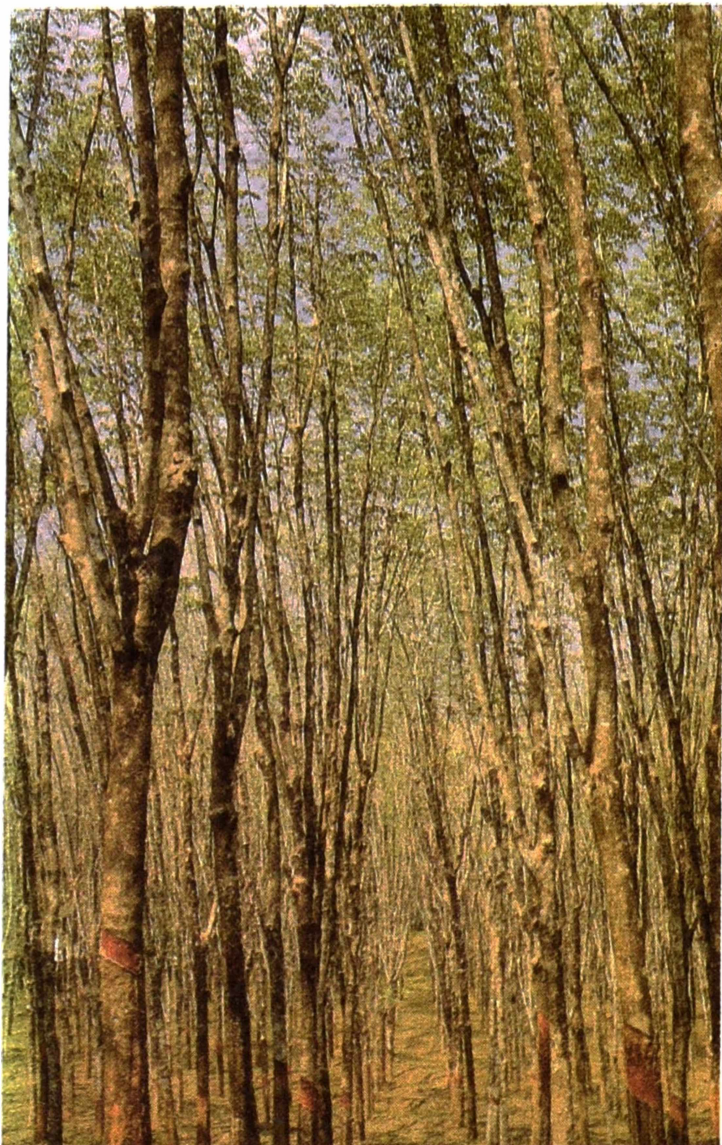

Figure 2.4: A **Rubber** plantation during February and March at the time of new flush formations. The maturing new leaves secrete considerable amounts of nectar during this period. See Figures 2.5 & 10.5.

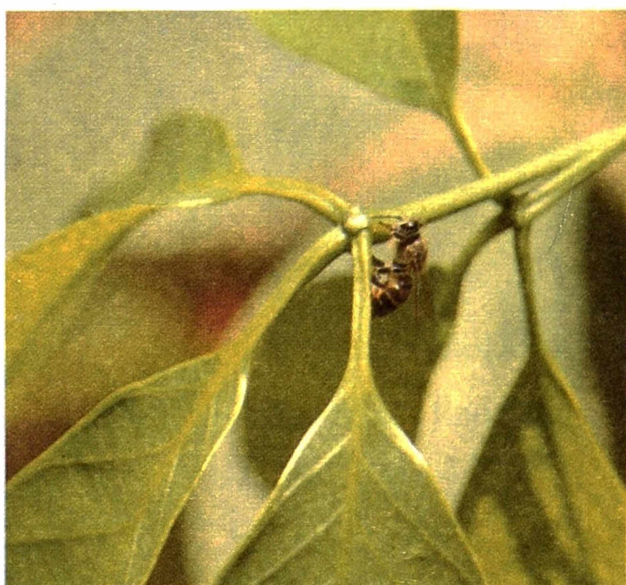

Figure 2.5: A honeybee collecting nectar from the extra-floral nectaries of **Rubber** leaves (*Hevea brasiliensis*: Euphobiaceae). Rubber secretes copious amounts of nectar and is good for honey production.



Figure 2.6: A Red Gum (*Eucalyptus robusta*: Myrtaceae) tree at its peak flowering and peak nectar secretory period between August and September in Bandarawela area. See Figures 2.7 and 10.5.



Figure 2.7: Red Gum which can give a good honey harvest.



Figure 2.8: Kalawel (*Derris* species) creepers which flower in great abundance in July-August decorate the Dry Zone forests in pink colour. Kalawel is a common creeper in the Dry Zone forest and is a good source of nectar.



Figure 2.9: The flowers of Kalawel (*Derris* species), an important contributor of Dry Zone honeys.



Figure 2.10: Multi-purpose small tree **Calliandra** (*Calliandra callothyrsis*: Leguminosaceae) grown in a home garden. Calliandra is a good foraging plant for bees and could be easily grown in home gardens for beauty, shade, fencing, animal feed, soil conservation and for fire wood.

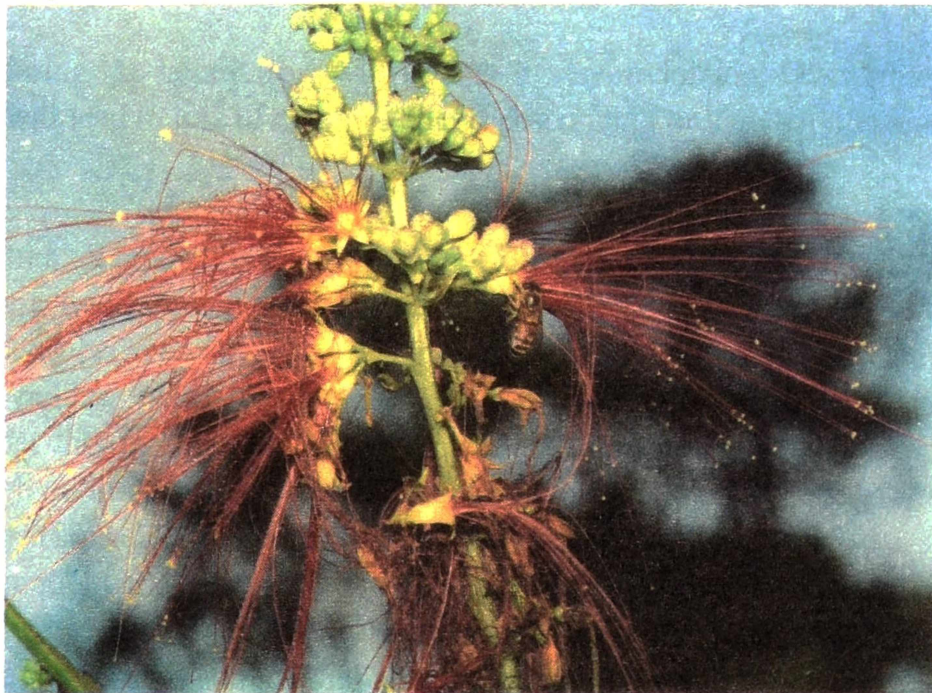

Figure 2.11: A honeybee sucking nectar from a Calliandra flower. The anthers at the end of long red filaments are also good pollen sources.

2.3. Foraging Range: an important limiting factor

The maximum foraging range of bees is about 600 metres but the average foraging distance is limited to a 300 meter radius. This is a very important factor to consider in establishing apiaries and the number of colonies which should be in each apiary.

Each apiary in a good beekeeping area should not have more than 5 colonies and the distance between apiaries should be at least 300 metres. Ideally the average flight range of bees in different apiaries should not overlap. Thus they should be situated 600 metres apart. However, the actual distance between apiaries and the number of colonies per apiary has to be determined locally depending on the following factors:

- 1 The number of colonies in the apiary.
- 2 The density and the quality of nectar sources during the dearth period.
- 3 The number of apiaries in the area.
- 4 The amount of supplementary feeding the beekeeper is willing to do during the dearth and growth periods. The important cost factor to be reckoned with.

In the case of **migratory beekeeping** where the colonies are moved right in to the honey flow, the number of colonies per **foraging area** can be much higher during the honey flow period. But these are exceptional situations.

Over-crowding during the honey-flow will lead to lower production. Over-crowding during the dearth period will lead to loss of colonies due to absconding or high supplementary feeding costs.

In Figure 2.12, three situations in colony layout are represented. In the 1st situation all the foraging ranges are overlapping and competition for food can be very high. This can be desirable in migratory beekeeping where all the colonies are brought right into the honey-flow where the nectar yielding plant densities are high. For example, during the period of nectar secretion in Rubber this may be realistic, but during other times the cost of supplementary feeding can be high or absconding can be inevitable. In the 2nd situation, the average foraging ranges do not overlap and colonies are kept spread-out. This could be a satisfactory arrangement throughout the year. The 3rd situation depicts the probable arrangement of colonies in a village in different home-gardens along a road-side. As we shall see later, if anybody thinks of going in for commercial honey-production, he has to maintain at least 10 or more colonies. In such an operation the cost of supplementary feeding can be a major recurrent cost.

Therefore, it is clear that honey-production is the final outcome of a number of interacting and interdependent factors. The honey yield the beekeeper collects is the excess nectar stored during a honey-flow over and above the maintenance and reproductive requirements of a colony for use during the dearth period to follow. Therefore, if one extracts honey, one has to make provision for the survival of the honeybee colony during the lean period.

Considering the above facts, it is clear that beekeeping for honey production implies the management of a population of bees in such a way as to get them to store the maximum amount of honey during a short honey-flow period. In this population-management exercise, the main role of the beekeeper is to coordinate the existing environmental conditions with the biological requirements of the honeybees nest in such a manner as to benefit from it.

The economic returns from beekeeping are divided as **Bee Products** and **Bee Services**. Honey, Wax and Pollen (in some situations) production can be considered as Bee-products and the pollination of cultivated crops and other plants can be considered as Bee services.

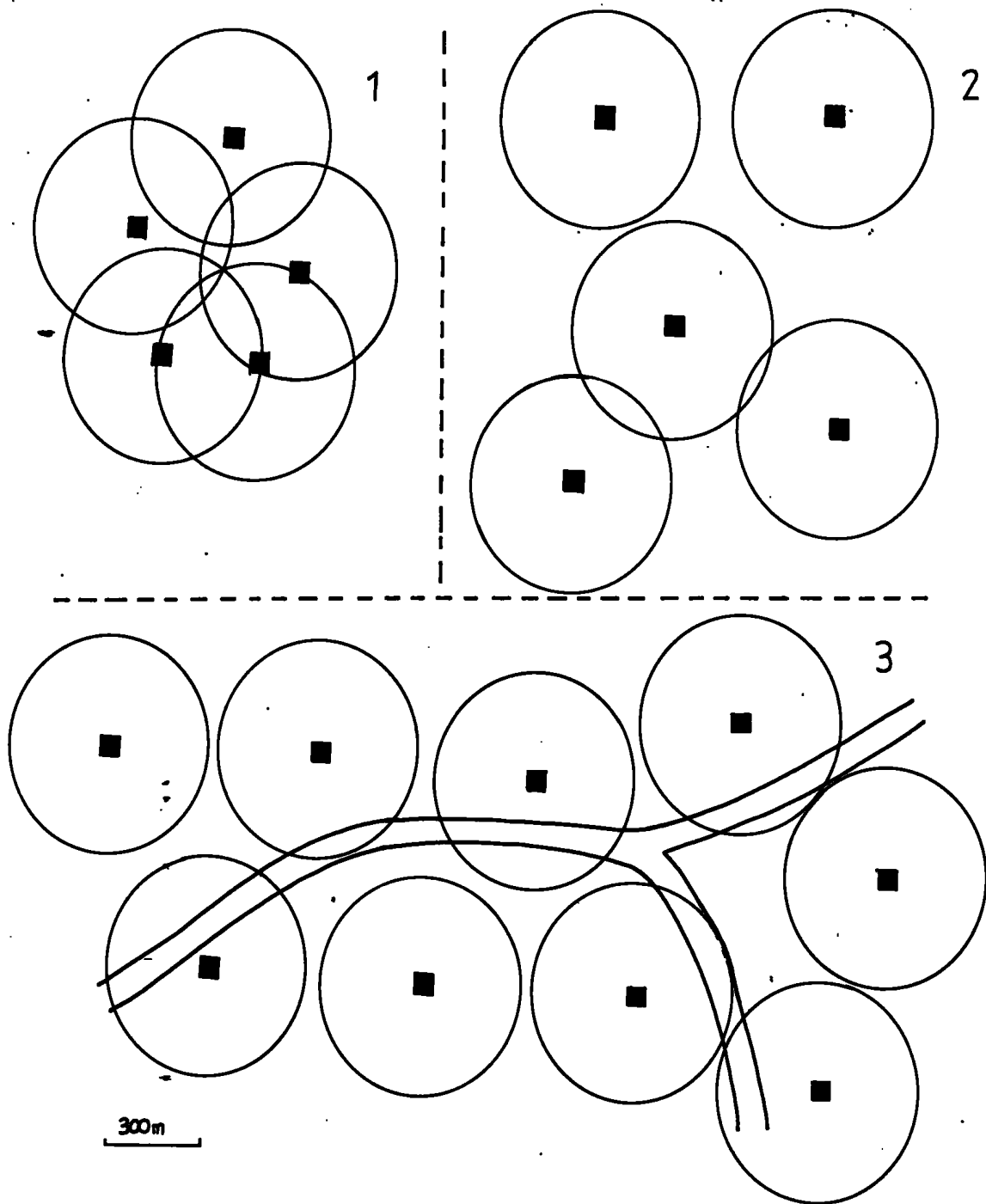

Figure 2.12: Apiary layout in relation to competition for food. A square "■" denotes a hive and the circle around it denotes the average foraging range. Here the average foraging radius is considered as 300 metres (See Figure 1.16, p. 22). It should be realised that each foraging radius comprises 28 hectares of land.

- 1** A crowded apiary where competition is high and all foraging radii overlap.
- 2** A spread-out apiary where foraging radii do not overlap and competition is reduced.
- 3** Colonies are kept in the home gardens along the road side and their foraging ranges do not overlap. This is a feasible colony layout plan for a village apiarist (see Section 10.4).

2.4. The Competition for Food Among Honeybees and their Migratory Habits

When all species of honeybees share a common foraging area, Bambara Bees will be the first to leave the existing foraging area for a new area once the environmental conditions become harsh and competition for food becomes evident³. Bambara Bees can make long distance migration and this phenomenon becomes quite clear during the times when Eucalyptus species (mainly Red Gum) begin to flower. With the onset of flowering in Eucalyptus plantations from July till October large numbers of Bambara Bee colonies come to the Bandarawela region for nesting (Figure 2.13). In this region the nectar supply becomes scarce with the commencement of monsoonal rain in October. Then the Bambara bees will migrate back, perhaps to the jungles of the plains. Usually Bambara colonies re-appear in dry zone forests with termination of heavy rain after December.

Similarly in the Nuwara Eliya and Hakgala areas Bambara nests become common during the flowering Nelu plants (*Strobilanthus spp.*: Acanthaceae). Perhaps the reason for naming a locality near Nuwara Eliya as Bambara Kele (meaning Bambara Forest) may have been due to the great abundance of Bambara nest during the Nelu flowering seasons in its vicinity.

Many places in Sri Lanka, yet not subject to the mass scale destruction of vegetation and with natural sanity remaining, have "Bambara Gas" or Bambara Trees for which Bambara Bees come to build their nests regularly in the process of their annual migratory cycle.

Though the migration of Bambara Bees are most distinct mainly due to the large size of their nests and communal nature of their nest building habits; a quite similar phenomenon occurs with Mee Bees too. Especially in our villages, colonies of Mee Bees will come to occupy the Bee Pots or the empty pots placed in the crotches of trees in home gardens, during the swarming season. Once the pot owner extracts honey from these pot hives and when the nectar supply from the environment depletes, these Mee Bees would leave the pot hives and migrate to other places with sufficient food supplies.

This migration or the absconding of the nest site due to the depletion of food supply from the environment is one of the major problems in managing Mee Bees and this aspect is discussed in Section 2.3 and Chapter 7 in detail.

³ Koeniger, N & Vorwohl, G (1979) Competition for food among four sympatric species of Apini in Sri Lanka (*Apis dorsata*, *Apis cerana*, *Apis florea* and *Trigona irridipennis*), J. of Apicultural Research 18 (2):95-109.

Koeniger, N & Koeniger, G (1980) Observations and experiments on migration and dance communication of *Apis dorsata* in Sri Lanka, J. of Apicultural Research 19:21-34.



Figure 2.13: The Communal nesting of Bambara Bee colonies in *Albizzia* trees at Diyatalawa. Here the "Bambara Trees" at the Arcadia Garden in Diyalalawa and thousands of Bambara colonies migrate to Hapulale-Diyatalawa-Bandarawela region (or the Red Gum Square or the area bordering Ohiya, Welimada, Ella and Haputale, see Figure 10.5, p.208) during the Red Gum honey-flow period.

3. Animal Keeping (Animal Husbandry) and Beekeeping

Animal-keeping (Animal Husbandry) essentially implies Man's attempts to modify the behaviour of the animal he chooses to rear for his advantage. An essential prerequisite of this attempt is Man's ability to take control of his animals by keeping them under his custody by means of various devices. The Cattle-shed, Nose-ring of Cows and Bulls, Dog-leash, Poultry Pen, Chaining Elephants etc., can be seen as some of the devices used by Man for the control of the animals he rears.

The device Man has invented to take honeybees under his control is called the "Hive". Man in his shrewdness provided a container to invite a swarm of nest-site-seeking honeybees to build their nest in the vicinity of his dwellings and tried to take control of them. This attempt is commonly evident when one sees bee-pots, bee-logs and other contraptions kept in our home gardens.

Therefore, the **Hive** is a container provided by man for the honeybees to build their nests and thus to take control of them for his advantage. The hives are of various types, ranging from a simple pot or a hollow log to a more sophisticated movable-comb-hive.

There is a subtle difference between beekeeping and other domesticated animal-keeping procedures. In this sense, all other animals are vertebrates who are considered more advanced while bees are insects. There is also a more distinct difference in their management as well, since Man has not domesticated the honeybees in the same way as he has domesticated the other farm animals; that is, he has not modified or been able to modify the behaviour of honeybees. The other farm animals have acquired many behavioural modifications due to man's influence which they would never do in their natural wild state and as such they cannot survive in the wild with their un-domesticated counterparts.

On the other hand honeybees who live in the hive provided by Man has not made any behavioural modifications to suit Man's desires and would have no difficulty in living in a natural nesting-site in the wild. Instead of domesticating honeybees, Man has only succeeded in providing an appropriate nesting site which allows him easy access to the products of the honeybees.

Therefore, we cannot use the commanding or the controlling attitude used in managing other domesticated animals with honeybees for successful beekeeping. The prime reason behind success in beekeeping is the beekeeper's knowledge of the requirements and behaviour of honeybees he rears and with this understanding he merely takes timely action to optimize the conditions for their natural behaviour. Such satisfied bees will reward the beekeeper with honey. Therefore, if we are to manage honeybee successfully, first we have to understand their ways and submit to them. In other words, only by providing the natural requirements of the honeybees can one expect to get profitable returns from them.



Figure 3.1: A pot hive that is commonly used in Sri Lanka.



Figure 3.2: A log hive is an other commonly used hive-type especially in areas close to forests in Sri Lanka.

4. Hive: An Important Device in Managing Honeybees

4.1. Movable Comb Hive

In the early days when natural resources such as the forest were abundant, there was no necessity for beekeeping. In the same way as Man hunted for wild animals he could plunder a wild colony of honeybees to collect the combs filled with honey.

With the expansion of human civilization and agriculture, there was less forest and more agricultural land and Man invented the hive to rear bees. The householder kept a hive to invite a swarm of bees where nature and bees did everything for the hive-owner who had only to extract the honey when the time was right. But the extraction of honey from these hives was not easy and it also caused considerable difficulty to the beekeeper as well as much destruction to bees themselves. It became a common occurrence to lose a colony after honey extraction.

A honeybee's nest consists of several parallel combs attached to and suspended from above (Figure 1.1). Here, the honey is stored in the upper part of the nest and the lower part contains the brood. Even in an individual comb this natural distribution may be seen clearly. This is a phenomenon that is commonly found in the nests of all stinging honeybees as illustrated in Figure 4.1. Thus a honeybees' nest may easily be divided into the brood nest and honey nest. The line of demarcation between these two areas in a comb is a band of cells stored with pollen (see Figure 9.1). Due to this natural arrangement of the honey being stored at the top, the rest of the nest gets destroyed or thoroughly disturbed once honey is taken from a naturally-built colony or even from a comb, since the combs are always attached to and suspended from the top. This means that, once a comb is tapped for the honey it is impossible to leave the rest of the comb intact, which was the central problem in managing bees before the invention of the movable comb hive.

Extraction of honey was a major difficulty in beekeeping up to the time of Rev. **Lorenzo Lorraine Langstroth** (1810-95) who invented the **Movable Comb (Frame) Hive**¹ with which the inevitable destruction of brood nest after honey extraction was overcome. Langstroth observed that the minimum space needed for the bees to walk around was always kept free by them and never filled up with wax. This minimum space needed to walk around was called the **Bee-Space** and its discovery was the pivotal point for later developments. As a result of this discovery, hives with movable frames containing brood and honey combs were constructed and this device ensured that no destruction was caused to a bees' nest in extracting honey. Extraction of honey became an easy task as now the combs built on frames were easily movable without hindrance to the bees. The advantages brought about by this new device

¹Often the modern hives are called Movable Frame Hives. But it may be more appropriate to call them **Movable Comb Hives**, since in Sri Lanka it has been amply demonstrated that frames are not indispensable in the brood-chamber and top-bars may be used instead (see Section 4.5.3.).

Figure 4.1

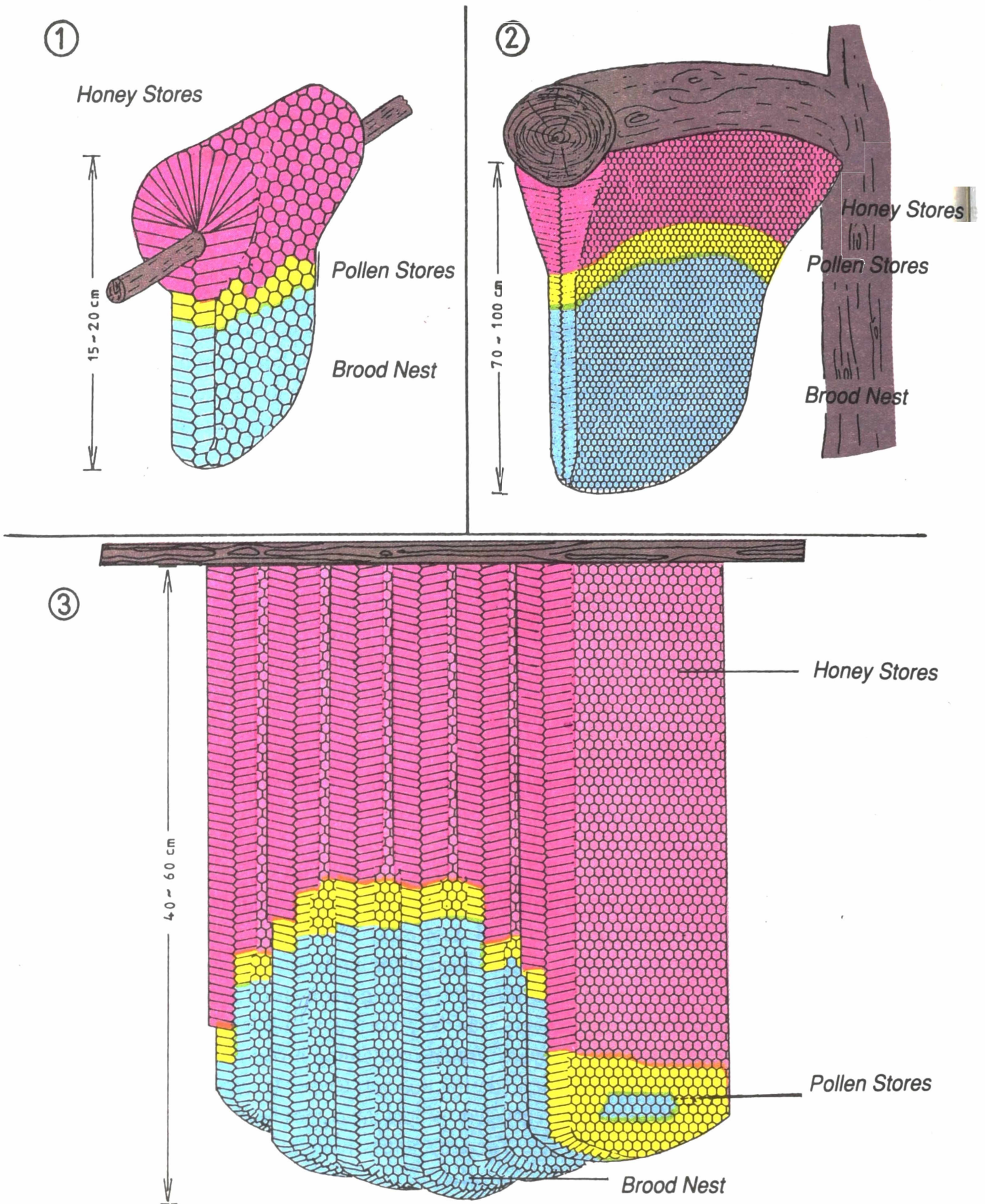

Figure 4.1: Diagrammatic representation of the relative positions of the honey nest and the brood nest in the stinging honeybees and their evolutionary development stages of nest architecture.

- 1** The exposed single combed nest of Danduwel Bee (*Apis florea*) is built around a twig and hangs down (semi-prostrate and semi-suspended nest). Honey nest is built around the twig.
 - 2** The exposed single combed nest of Bambara Bee (*A. dorsata*) built underneath a branch of a tree (completely suspended nest). Honey nest is suspended from the branch.
 - 3** The enclosed nest of Mee Bee (*A. cerana*) has several parallel combs and is suspended from the substrate above (completely suspended nest).
-

made a great impact on beekeeping world wide and resulted in beekeeping becoming a large scale industry in many countries. Within 25 years of this discovery, several auxiliary appliances were developed for honey production to become a properly organized industry.

4.2. Some Vital Measurements for Hive Designing

In designing movable comb hives, three important natural phenomena in a honeybees' nest are considered and these are the Bee-Space, the Comb-Thickness and the Comb-Spacing.

In a movable comb hive, there are two major nest areas or two functional units called the brood-chamber or brood-box where the brood-rearing activities take place and honey-chamber or honey-super where the honey is stored. The combs in the brood compartment also consist of all the pollen stores and a small quantity of honey which is essential for brood-rearing. Thus the brood-chamber is considered a single functional unit. The combs in the honey compartment are exclusively meant for the storage of honey and is the other functional unit that provides income for the beekeeper.

Even though we consider the brood-chamber and the honey-supers as two functional units, the build-up in the honey-supers are entirely dependent on the growth and developments that takes place in the brood-nest as we see later in Chapter 5.

4.2.1. Bee-Space

Bee-space implies the minimum space required by bees for their movement without hindrance within the nest. It is defined as the space between two parallel brood combs on which two layers of bees can stay, keeping back to back. This space is estimated to be between 8.0 mm to 9.0 mm for Sri Lankan honeybees. If the space provided between movable parts of the hive exceeds the above specification, the bees tend to build Burr-Combs (or Brace-Combs) between the parts rendering them immovable. If the space between movable parts of the hive become less than the bee-space, the bees tend to seal up such spaces with wax, again making the movable parts immovable. Therefore the concept of bee-space should be strictly followed horizontally and vertically between adjoining combs in the designing and in the manufacture of hives.

4.2.2. Comb Thickness

The thickness of a worker brood comb is between 20.0 mm to 21.0 mm while the thickness of a drone brood comb may be between 24.0 mm to 25.0 mm. The thickness of honey combs are highly variable and sometimes may extend up to 50 mm. In designing frames and top-bars for comb building, what is considered as the comb thickness is the thickness of the worker brood comb which is about 20 mm.

4.2.3. Comb Spacing

Comb spacing is the centre to centre spacing of two adjoining worker brood combs. In hive designing this is taken as 28.0 mm. This is the distance between centre to centre in adjoining top-bars or top-bars of frames in a movable comb hive.

These three concepts and some other natural phenomena in a honeybees' nest are illustrated in Figure 4.2.

Modern hives constructed following under-mentioned principles:

- 1** Allow the free movement of combs for effective management of bees (**Movable Combs**) and
- 2** Facilitate non-destructive honey harvesting (**Reuse of Combs**).

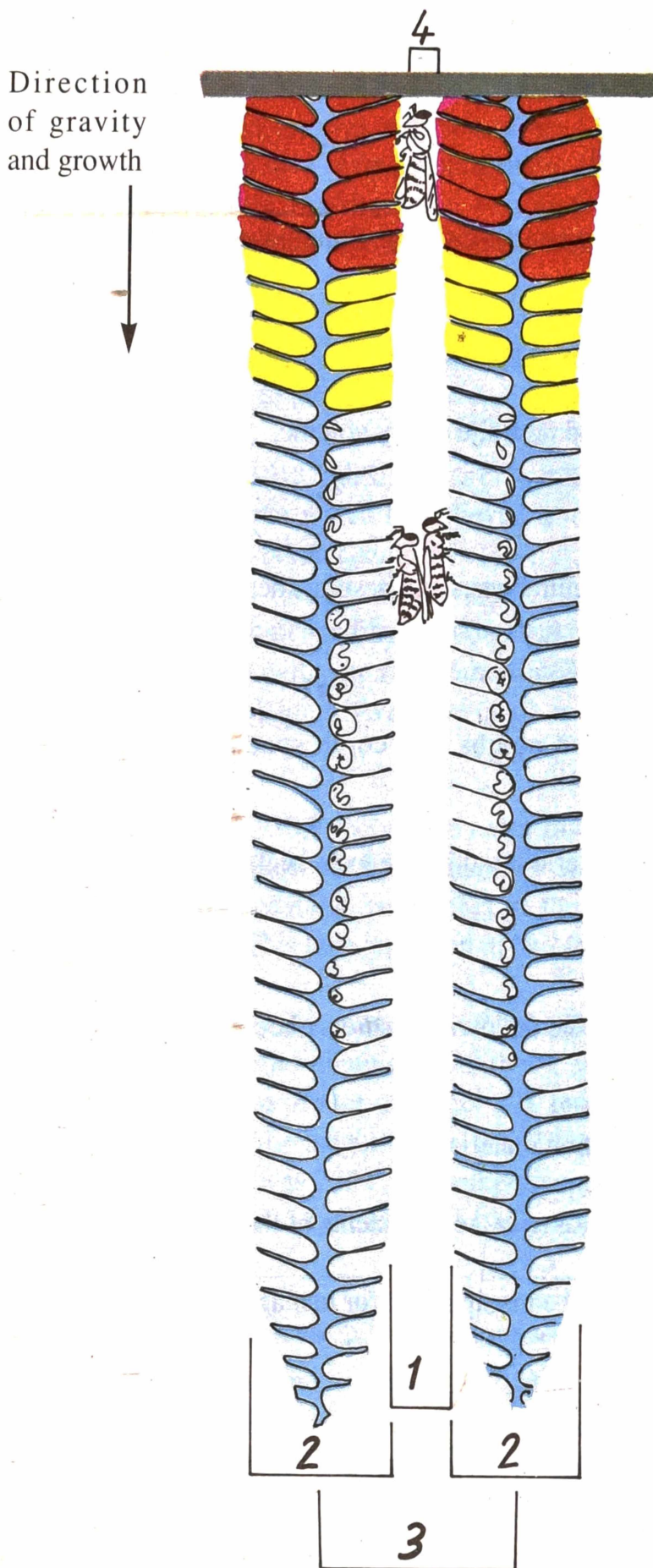

Substrata on which the combs are suspended

Honey area of the comb at the top.

Pollen area of the comb below the honey area and above the brood area.

Brood area of the comb below the Pollen area.

1. **Bee space** between brood combs, with minimum space for two bees (or two layers of bees) on adjoining combs to pass by with ease. This is considered as **8mm** in hive designing.
2. **Comb thickness** measured in the worker brood area of the comb. Taken as **20mm** in hive designing.
3. **Comb space** measured from centre to centre of two adjoining combs, taken as **28mm** in hive designing.
4. **Bee space** between two combs stored with honey. Only a single bee or single layer of bees can move about within this space and is about **4mm**.

Figure 4.2:

Some natural Phenomenon in Honeybees' nest important in designing movable comb hives.

4.3. Hive Design Criteria for *Apis cerana indica* in Sri Lanka

4.3.1. Preliminary Considerations

The following points should be studied to assess the existing situation as the initial step in designing hives for honeybees:

- 1** Natural nesting sites of the honeybees in the area.
- 2** Naturally-developed nest volume and nest-site cavity volume.
- 3** Maximum size of the brood nest.
- 4** Other animals associated with the natural nests and nesting sites of honeybees.
- 5** Local eco-climatological conditions.
- 6** Bee-space, thickness of the brood combs and comb spacing in the nests of honeybees.
- 7** Types of hives and construction material used by the local beekeepers.

4.3.2. Design Considerations

After having assessed the existing situation, the following matters should be considered and incorporated in the hive designing:

- 1** Availability of different construction material.
- 2** Adaptability of the hive for the biological requirements of the honeybee colony.
- 3** Ease with which the colony could be manipulated for management.
- 4** Cost of Production.

4.4. Suitable Hives from a Historical Perspective

The suitability of hives for *Apis cerana* in Sri Lanka is a question as old as the history of modern beekeeping in Sri Lanka. Even the first published article on beekeeping in Sri Lanka discusses the suitability of different hives (Jayatillake, 1881 see Chapter 12 Appendix 12.1). Ever since then, there have been many changes in the hive design. The following is a brief survey of the developments up to the present day.

- Jayatillake (1881)² who observed the undue destruction caused by honey hunters to the Mee Bees and Bambara Bees in gathering honey with grief and sought an alternative. As a result of this, he was the first in Sri Lanka who attempted to rear Mee Bees in a movable frame hive obtain from Britain. However, he concluded that the British hive to be undesirable for the local bee and with many years of experimentation he recommended that a hive arrangement with flat pots and pans made of burnt clay is more suitable.
- Benton (1881)³ made suggestions on developing suitable hives for Sri Lanka's honeybee during his visit to the island.
- Goonatillake (1918)⁴ designed a hive with eight frames which had internal dimensions 267mm x 133mm which he believed as best suited for our bees. (Available comb area 2841cm² in the brood chamber)
- The hive recommended by Ceylon Beekeepers' Association in 1920 (Drieberg, 1921)⁵, had ten frames with internal dimensions 279mm x 127mm and super with frames of internal height 89mm (Available comb area in the brood chamber 3543cm² and in each super 2483cm²)
- Kannangara (1938)⁶ recommended a hive with seven frames with 194mm x 152mm internal dimensions for brood chamber and super with half the height of brood frames. Therefore the available comb area of the brood chamber was 2064 cm² and per super was 1032cm². This hive was used in late 1930s and early 1940s
- Butler (1953)⁷ and Baptist (1954)⁸ introduced a hive where brood frame was 280mm x 152mm in internal dimensions with six such frames in the brood chamber and honey frame which was 76mm in height (i.e. half size of the brood frame and thus the honey super was half the height of the brood box). Therefore the available comb area of the brood chamber was 2554 cm² and per super was 1277cm². This hive was the standard hive recommended by the Sri Lanka Dept. of Agriculture till 1986.

² Jayatillake, S (1881) Ceylon Bee Culture, J. Royal Asiatic Society (Ceylon Branch) 7 (23): 27-31.

³ Benton, F (1881) Ceylon Bees, etc, A Peep into a Beehive, Trop, Agriculturist 1881 June: 13, 29, 42-43 & 52-55.

⁴ Goonatillake, AP (1918) Beekeeping in Ceylon (Second Series) Trop. Agriculturist 50:284-285 & 51:376.

⁵ Drieberg, C (1921) Report of the Secretary, Ceylon Beekeepers Association. Trop Agriculturist 57 (4):266-268.

⁶ Kannangara, AW (1938) The Modern Hive. Trop. Agriculturist 90 (4):238-239.

⁷ Butler, CG (1953) Possibilities of beekeeping development in Ceylon, Report submitted to Ceylon Dept. of Agriculture at the end of this assignment in Ceylon. (Unpublished, recommendation for hive design).

⁸ Baptist, BA (1954) The suitability of various Beehive types for *Apis indica* in Ceylon, Proc. Ceylon Assoc. for the Advancement of Science. See. Bee, Colombo. p 11.

- Punchihewa (1986)⁹ introduced a hive with a 8 liters brood box with provision for 8 frames (comb area 2352 cm²). This hive is still being improved and modified along with management improvements. A single super is almost half the size of the brood chamber and the number of supers required depends on the beekeeping conditions (see below).

Most of these designs were recommended by the Sri Lanka Department of Agriculture as the suitable hive during the period concerned. However, even today many successful beekeepers use their own design and they are all good.

It is often thought by many people that a colony of bees in a movable comb hive is happy and they would do everything to give honey to the hive owner. Therefore, very often the hive has to take the blame for failures in beekeeping. The management of bees is the most important role in successful beekeeping and the movable comb hive offers many possibilities for effective and efficient management practices.

It is also in the minds of quite a number of people that bees in a movable-comb-hive should be looked at very frequently to determine their condition. Of course, knowing the condition of the colony is very desirable but frequent interference for this purpose may be disastrous.

Understanding bee-behaviour and adoption of appropriate management practices are discussed elsewhere. Here we consider some of the features desirable in a hive in order to facilitate the required management practices.

4.5. Features of a Suitable Hive for the Present Day

The following is an account of different hive parts and suitability of these under local conditions. Figures 4.3 and 4.4 illustrate the dimensions and assembly of different hive parts.

4.5.1. Floor-board

The floor-board is the lowermost part in a movable-comb-hive on which the rest of the parts are placed. It generally serves to collect many of the debris from the brood combs such as the capping. Often many scavenging insects such as beetles, wax moth larvae, etc. dwell in this debris. Also during the rainy season, due to gusty winds water too tends to get collected on the floor-board.

Many floor-boards are flat and are kept horizontally. On such floor-boards, the tendency for debris to get collected is greater. There is also the proneness to wood-rotting. Therefore slanting bottom floor-boards seem more desirable.

In tropical conditions, termites too are very common and they can inflict much damage almost overnight to a wooden floor-board.

⁹Punchihewa, RWK (1986) Metric Hive: a new hive design for *Apis cerana* in Sri Lanka. Report submitted to 3rd steering committee of the Apiculture Project, 1986 July, Sri Lanka Dept. of Agriculture, Peradeniya (Unpublished).

Of course, we can use good quality timber and many effective wood preservatives to overcome the above problems. But, needless to say, it also increases the cost. As an alternative, cement floor-boards with slanting bottoms seems quite practical, cheap and durable. Cement floor-board may not be as suitable as a wooden floor-board in transportation due to its weight and inclination to break. The cement floor-board shown in Figure 4.5 has a built-in entrance, a bottom slanting towards the entrance to prevent the retention of water and has a good utility value. A hive placed on a floor board with an in-built entrance and in-built stand is shown on the out side of the back cover (see Section 4.5.9).

The entrance in the slanting bottom floor-boards also serves as a clamping facility to hold a top-bar comb when one wants to remove the bees (Figure 5.8).

The dimensions of the floor-board should match the dimensions of the brood chamber which will be placed on top of it. For the hive we are considering here the floor-board should have internal dimensions 230mm x 230mm and would have a slanting bottom towards the front. The wall for keeping the brood box would be 15mm thick and 15mm high in the back side and 30mm high in the entrance side. The rear leg would be 40mm high and the front leg would be 25mm high. The bottom will be 15mm thick.

4.5.2. Brood Chamber

In general the brood chamber should be considered the most important functional compartment of the hive. In Sri Lanka, for *A. cerana* and the brood area with its honey and pollen stores usually occupy a volume of about 8 liters and has between 5 to 9 combs, depending on the shape of the nest cavity.

A brood box with internal dimensions 230mm x 230mm x 150mm seems quite adequate for many situations. Such a brood box can take up to 8 combs of 210mm long and 140mm high. This brood area when properly managed can generate enough bees to fill up honey supers up to 4 times (i.e. 8 honey supers) the size of the brood chamber (see Figure 5.17, p.93).

To rest the frames or top-bars, a groove 9mm deep and 5mm broad should be made in any one of the two opposite walls.

The name "movable frame hive" itself implies that the frames are used for comb building. But with *A. cerana* in Sri Lanka frames may not be necessary for comb building. The use of top-bars may have greater advantages. Let us examine the case.

4.5.3. Top-bars vs. Frames for the Brood Chamber: a comparison

A. cerana by nature will almost never fill up a whole frame. It starts building from the top-bar of the frame and the comb grows down-wards and side ways but stops further expansion by the time it reaches about 8mm to 10mm from the sides and the bottom of the frame. If the combs contain honey the bees will extend such comb areas to the side bars, perhaps for additional strengthening of the heavy honey area of the comb. As a general rule, one can see three sides of the comb unattached to the frame and thus we see that the bees use only the top-

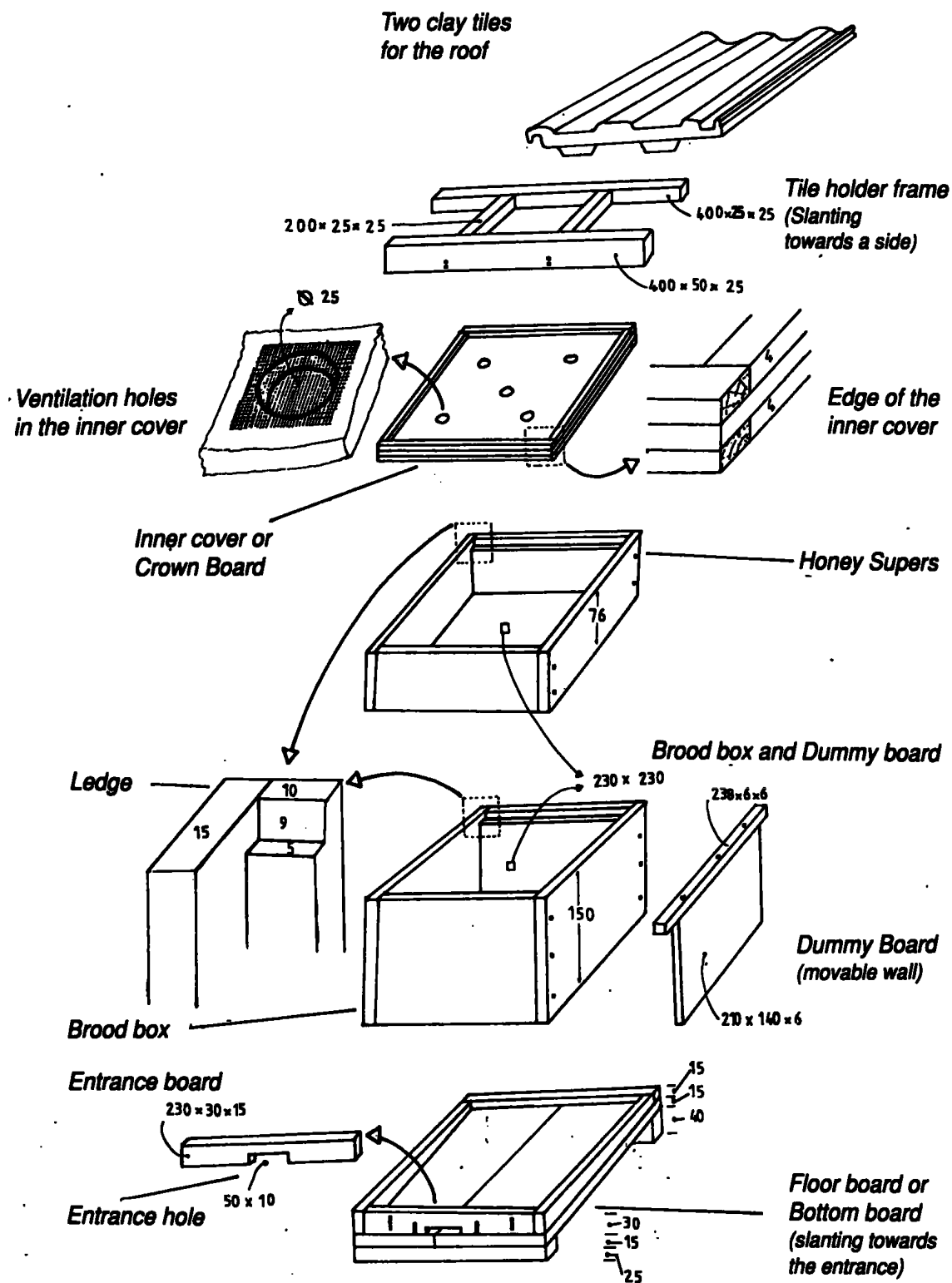

Figure 4.3: Different parts of a suitable hive design for Sri Lanka. The thickness of the wood used in hive body can vary from 12mm to 15mm. In the illustrations it is taken as 15mm (Not to scale. All dimensions in millimetres).

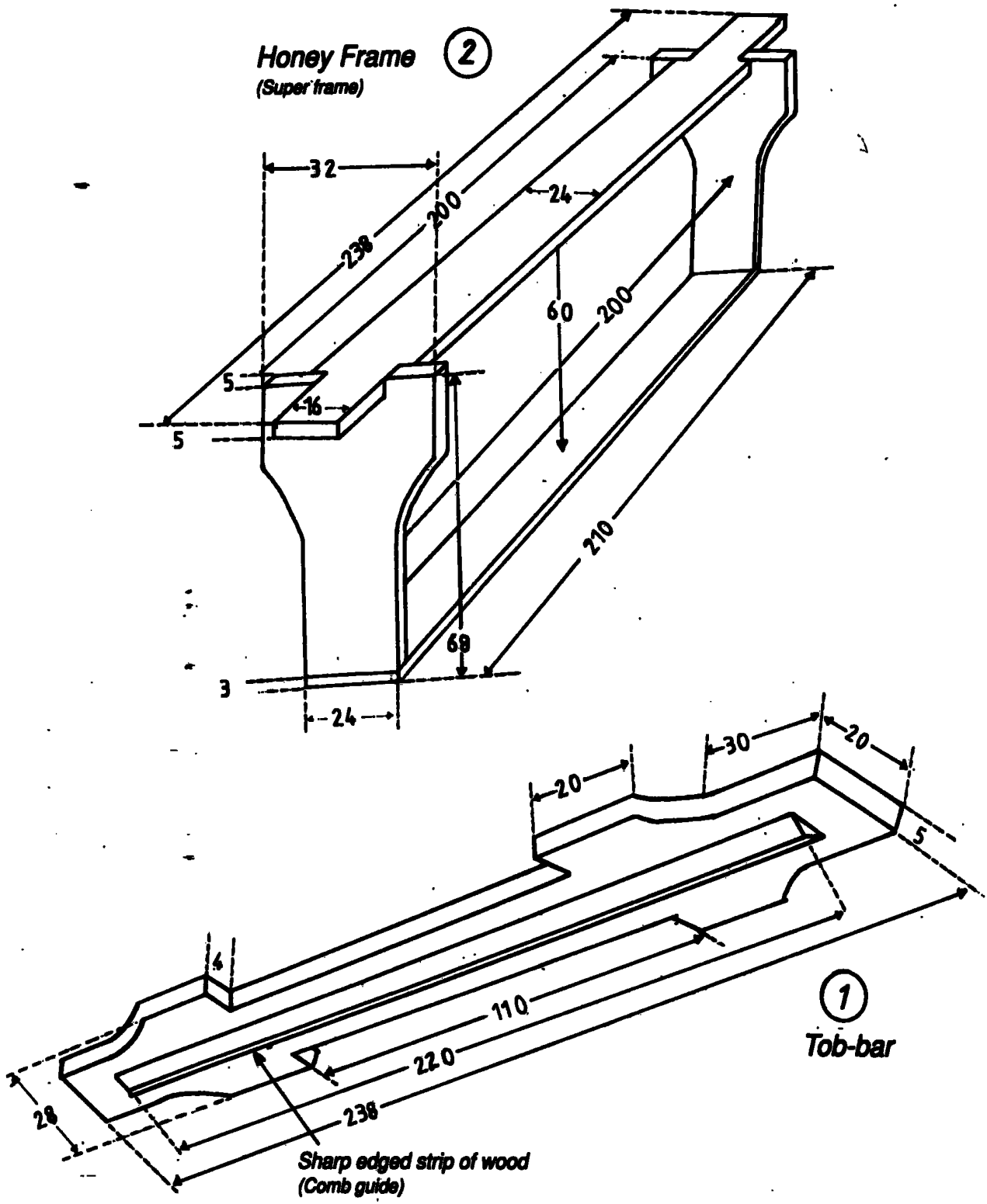

Figure 4.4: Illustrations of the Top-bar (1) for brood combs and Honey frame (2) for honey supers. Note the sharp edged strip of wood fixed to the bottom side of Top-bar, which will function as a comb guide so that bees would make the combs straight. (Not to scale. All dimensions in millimetres).

bar of the frame. Further, the comb occupies only about 80% - 85% of the expected comb space given. Even though the comb space in a brood frame is 210mm x 140mm, the actual size of the largest combs built in them are only about 190mm x 125mm. In other words, the bees would like to keep a certain distance between the combs and walls of the nesting cavity (the concept of bee-space) and they would attach the combs to the walls of the nesting cavity only when the comb contains honey. Therefore, if the bees were allowed to build combs in top-bars in the same brood chamber the comb will be about 210mm long and 130mm high which is about 96% of the expected size and about 120% more than the actual comb that would be built in the frame. A comb built on a top-bar and another built on a frame are shown in Figure 4.6 for comparison.

The advantage of having larger combs are that once the combs get older, these old combs could be used in honey frames in the honey supers. A single top-bar comb will fill up the comb space in two honey frames. Unlike in countries with well-developed honey production industries, in Sri Lanka we cannot get comb foundations and even if one wants to make them it would be a time and money consuming exercise. In fact recent research has proven that bees prefer to store honey in old brood combs rather than in new combs. It is therefore abundantly clear that the more practical thing to do is to use what is already available and is also much better.

It may be argued that a comb built inside a frame is better protected, especially from a beekeeper's point of view. During hive manipulation such combs are less prone to injury and a comb built on a frame could easily be kept on the ground vertically, whereas a comb built on a top-bar cannot be kept on the ground as it is, but has to be inverted so that the top-bar touches the ground. However, it should be admitted that this is a minor consideration in hive manipulation and perhaps the only time when one wants to remove combs from the brood box will be the time of dividing for colony multiplication. In colony dividing there has to be another brood box so the question of keeping combs on the ground will not arise.

There may be instances where one has to remove a comb and remove bees. This could be easily done by placing one end of the inverted top-bar in the entrance and sending some smoke from top which will make the bees go down and enter the hive (see Figure 5.8).

Selection of brood frames or top-bars for the brood chamber is perhaps a matter of personal preference and obviously frames will be more expensive than top-bars. Nevertheless, one should remember that by going in for the cheaper top-bars there is no loss but rather a gain of some advantages.

An additional triangular shaped strip of wood is fastened to the lower side (the side that will be placed towards the bottom in the brood box) called a comb-guide (see Figure 4.4). The comb-guide has an advantage in that it will encourage the bees to build combs straight (Figure 4.7).

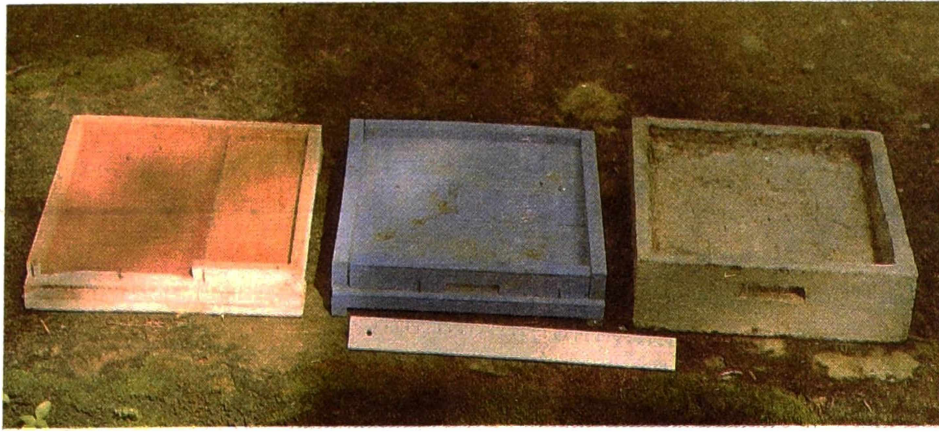

Figure 4.5: Various types of floor boards. Flat bottom (left), Slanting bottom (middle) and Cement slanting bottom (right) floor boards that could be used to keep the brood box.

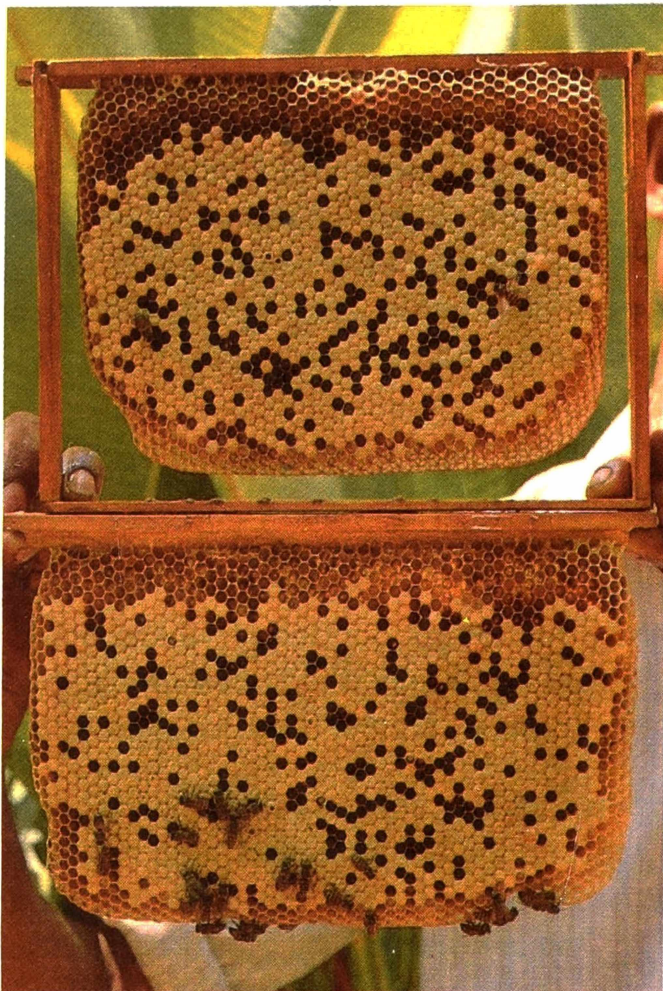

Figure 4.6: Comparison of two combs of the same age from the same hive built on a Top-bar and on a Frame. Combs built on Top-bars are always larger and therefore more useful in supplying combs to the honey supers.

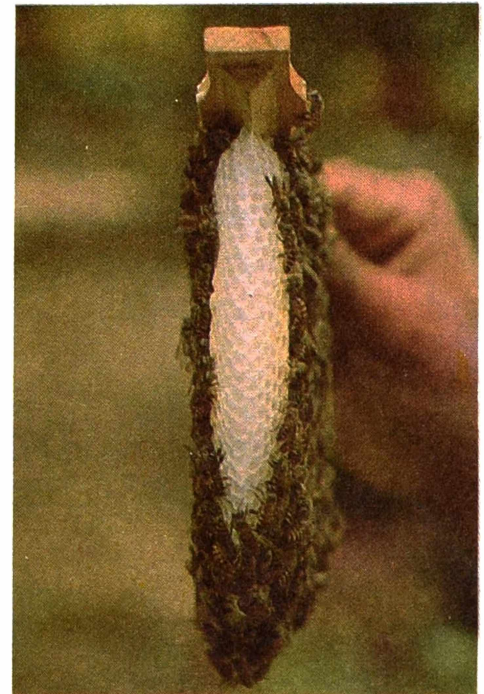

Figure 4.7: The comb attached to the comb guide built straight along it. Honeybees prefer to build combs on sharp edges and therefore by providing a sharp edge we can get them to build straight combs.

4.5.4. Dummy-Board or Movable Wall

This helps to regulate the size of the brood nest and is specially important in managing small colonies. As we shall see later, this can function like a movable wall in giving required space for a growing brood nest (see Figure 4.3).

Use of Movable Wall or Dummy-Board in regulating nest size is discussed in Chapter 5.

4.5.5. Honey Chambers or Honey-Supers or Supers

The dimensions of the honey chamber or honey supers are such that it is almost half the size of a brood box. The internal dimensions are 230mm x 230mm x 76mm. As in the case of the brood chamber, the supers also has two grooves (9mm deep and 5mm wide) on two opposite sides to place the honey or super frames. Generally 8 honey frames could be placed on a single super but it is more advantageous to place only 7.

By placing 7 honey frames, the honey comb will be drawn much thicker by the bees. This is advantageous for the beekeeper since it provides more honey per frame. Therefore the honey frames designed for the super have side bars of 32mm breadth which would enable the placing of 7 of them on a super. The internal dimensions of this super frame are 200mm x 60mm. The earlier honey frames had a side bar breadth of 28mm just like in brood frames and internal dimensions are 210mm x 60mm but it was seen that broader side bars are much better as they give rise to thicker honey combs and increased yields.

One might wonder why the honey chamber is half the size of the brood chamber and why only frames and not top-bars are used here. That is a very sensible question and let us see its rationale.

If one uses larger honey chambers, the honey combs also will be large like the brood combs and correspondingly the centrifugal honey-extractor also will have to be large, which only means more money to buy one. A large honey-extractor gives no added advantage.

If the honey supers are small and the frames are correspondingly small, then honey could be extracted more frequently as they get filled sooner than larger ones. During a honey-flow, more frequent honey extractions are advantageous as it would remedy the congestion in the nest and encourage bees to collect more.

If combs built in brood frames are moved to the larger super on top for honey storage, it will force the bees to complete the three unattached side with combs for better strength. This is very essential in honey extraction to prevent comb breakage. But naturally the bees do not do a good job. Therefore, in such instances wired-comb-foundations with additional strength for the comb has to be provided as done in countries with well-developed honey production industries. But even the normal comb foundations are still not a reality in a Sri Lankan context. This is perhaps an unnecessary expense.

Therefore, considering all the aspects, for the present it is better that we use the old brood combs in a smaller super frame and the hive be designed for this purpose.

Often it was thought a single super or two supers are enough for each colony. This again is a decision each individual beekeeper has to make. But nevertheless it is clear that there should be at least two supers if one wants to make honey. If the colony is well-managed, it can have a population that will grow up to 6 supers or 3 times the size of the brood box. Such a colony could yield really good harvests during a honey-flow, perhaps well over 10 kg. It is also important to have combs in all super frames and not just empty spaces in them. Figure 4.8 shows a honey super with 7 frames with combs in them, a brood box with 8 top-bars for 8 brood combs and all comb areas covered with bees.

4.5.6. Crown Board or the Inner Cover

The inner-cover is a flat piece of wood with a few ventilating holes, which will demarcate the upper limit of the nest (Figure 4.3). This being a movable part, it could be placed anywhere from the top of the brood chamber to the last super depending on the size of the colony. As we see later, in combination with the dummy-board, this can be used to regulate the nest size. Use of the inner cover in regulating nest size is explained in Chapter 5.

4.5.7. Roof

Though the inner cover closes up the nest area it needs further protection from sun and rain and thus a roof becomes essential. Roofs could be turned out of wood and could be covered with roofing tar paper to make them weather proof. This sort of roof will last a considerable time with good care.

But ordinary roofing burnt-clay-tiles also can be used for this purpose. The cost of such a roof will be considerably lower. If one wants to use roofing tiles, the tiles should be placed slanting towards one end. Otherwise during rain, the overlapping groove tends to get flooded with water which can eventually damage the inner cover. To prevent this an appropriate wooden frame can be used. As shown in Figure 4.9, the wooden frame is so constructed as to give a slope to the tiles.

Though the tile roof is much cheaper and can be used for a very long period, the tiles are heavy and breakable compared to the tar-paper roof.

4.5.8. Entrance Guard or Queen Guard

This is a piece of metal strip with holes that allow only workers whose thorax is smaller to pass through but not the drones and queens with larger thoraxes. The height of this hole is the same as the diameter of the worker brood cell into which a worker can enter with ease but not the drones and the queen. The principle of the operation of the queen guard is the same as for



Figure 4.8: A brood box with 8 top bars for 8 brood combs, honey-super with 7 frames with combs filling them and all comb areas covered with bees.



Figure 4.9: Comparison of two different types of roofs that can be used with hives.

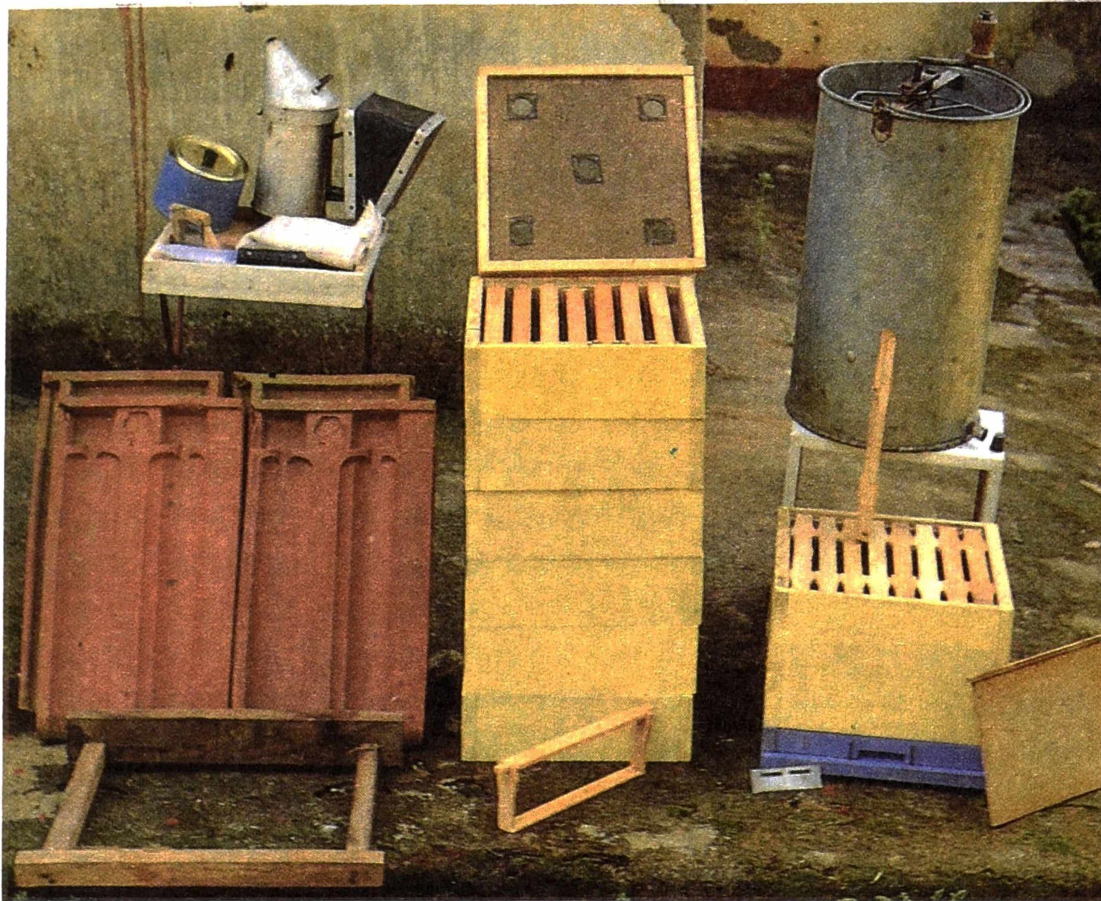

Figure 4.10: Different parts of hives, appliances, and some auxillary tools needed for beekeeping in Sri Lanka. On left (top): feeder can, smoker, queen-cage, knife & a towel. On left (bottom): two clay tiles & wooden frame to keep tiles. Middle: Inner-cover and six honey-supers with a honey frame in front. Right (top): Honey extractor Right (bottom): a top-bar, Brood box with 8 top-bars, Floor-board, Dummy-board, entrance-guard.

the queen excluder (see Section 4.9). Queen-excluders are used extensively in countries with well-developed honey production industries in order to prevent the queen coming to honey supers to lay eggs.

It is often considered that the entrance guard can prevent the problem of absconding by not allowing the queen to leave the hive. Hence, this is also called the queen guard. The queen-guard is also useful in catching swarms where the swarm may tend to fly away again soon after they are taken inside a hive. In this instance the prevention of the queen leaving will make the worker bees return. A similar method is used to break the absconding impulse when a colony tries to abscond (see Chapter 7).

4.5.9. Other Beekeeping Appliances and Auxiliary Tools

Two other important appliances, namely the smoker and the honey-extractor, are discussed separately in Chapters 8 & 9. However, auxiliary tools such as a small knife, a queen cage, a towel, feeder cans, etc. too are indispensable items of successful beekeeping. The major and minor items needed in beekeeping are shown in Figure 4.10. The picture of a hive with combined floor-board as shown out side of the back cover of this book consists of the entrance and stand in-built to it with cement may be appropriate in many situations, such as with problems of termite attack and wood decay due to wetness.

It is also important to realize that a hive with a colony of bees should be kept on some sort of a stand to prevent termite attacks on the wood, wood-rotting due to too much wetness in the soil and to prevent rain water splashing, etc. To prevent hive parts sliding on each other, the whole hive assembly from floor-board to inner cover should be tied up with a Coir (Coconut fibre) rope. Finally the roof must be placed on top.

4.6. Suitable Timber for Hive Construction

Many types of timber can be used for this purpose and it is difficult to say which are the better ones. However, with the increasing cost of timber, it may not be practical to use the high quality timbers. **Boron treated Rubber wood** has been tried and seems quite good for hive body construction. But it tends to warp when used in top-bar and frame construction. **Lunumidella** (*Melia dubia*: Meliaceae), **Ginisapu** (*Michelia champaca*: Magnoliaceae) etc. too have been used successfully for hive body construction

Any wood that would not split on driving of nails, especially when they are sawn to thinner sizes (eg. 3 mm and 5 mm thick), can be used for top-bar and frame construction. **Pinus** wood (*Pinus* sp.) and **Cypress or Cedar** wood (*Cedrus* sp.) are commonly used for this purpose.

What is important in selecting timber is that the wood should not twist or warp when it is used in the outside environment. It is very essential that some kind of a water repellent paint is applied on an outer side of hive bodies and on the entire floor-board for durability. Most of the

wood preservatives available in the market can be used as a primer coat on floor-boards for greater durability without any harm to bees.

4.7. Hive Manipulation

As it was discussed previously, the main advantage of the movable comb hive is the ability to manoeuvre the honeybees' nest and specifically the combs. However the handling of combs has to be done in a special way so as not to inflict any damage on them, as they are quite susceptible of breaking. Combs should not be turned around carelessly.

Due to the high susceptibility to breakage in natural combs, the comb foundations reinforced with thin metal wires are used in countries with well developed honey production industries. But this practice does not exist in Sri Lanka.

In this context what is more important is to know how to handle combs. In Figure 4.11 the basic principle in handling combs are shown. One should make sure the combs are never turned round on the broader side (axis 3) but may be safely turned round on the other two axes (1 & 2). In managing hives, it often becomes necessary to turn combs. The procedure is clearly shown in Figure 4.12. In the event of it being necessary to look at the other side of a comb, the steps to be taken are shown in Figure 4.13. In all these methods the basic principle explained in Figure 4.11 is strictly followed and therefore there is no possibility of damage to the combs.

4.8. Comb Breakage and Repair

It is not uncommon for a beginner to break a few combs due to wrong handling. But such could be repaired and continued to be used without a problem. In top-bars or frames in hives, often the combs break from the point of attachment (as shown in Figure 4.14) due to the turning of the comb in a wrong manner. If this happens, it could be re-attached with the use of Banana fibre. Banana fibre taken from the mid-rib of a dried-up leaf or from the stem is ideal for this purpose. Keeping the broken pieces together and tying it up with **Banana fibre** as shown in Figure 4.15 will help the bees to mend it once it is put back in the hive. One important point to remember is that bees do not do a good job in mending if the line of breakage is through the honey area of the comb. If such a thing happens, one must make sure to remove the honey area from the line of re-attachment so that bees will fasten it strongly and properly. The broken comb temporarily put together with the help of Banana fibre is now returned to the colony (Figure 4.16) which will, in a day or two, repair it completely. The advantage of using Banana fibre is that bees themselves can cut and remove it eventually. Perhaps, a few hours after a broken comb temporarily fastened with Banana fibre is given back to the hive, one can see the bees removing pieces of Banana fibre from the hive entrance. If other fastening material such as Rubber bands, Jute strings, etc. are to be used, the bees are unable to remove it themselves. The pieces of fibre un-removed by bees could be removed by the beekeeper later.

When capturing natural colonies from the wild and transferring them to modern hives, the same procedure could be used in fastening brood-combs to top-bars or to frames. What is important to remember is not to have areas containing honey in the line of attachment and to cut the combs straight on the side to be fastened to the top-bar or to the frame, so that the bees could fasten it well to the straight top-bar.

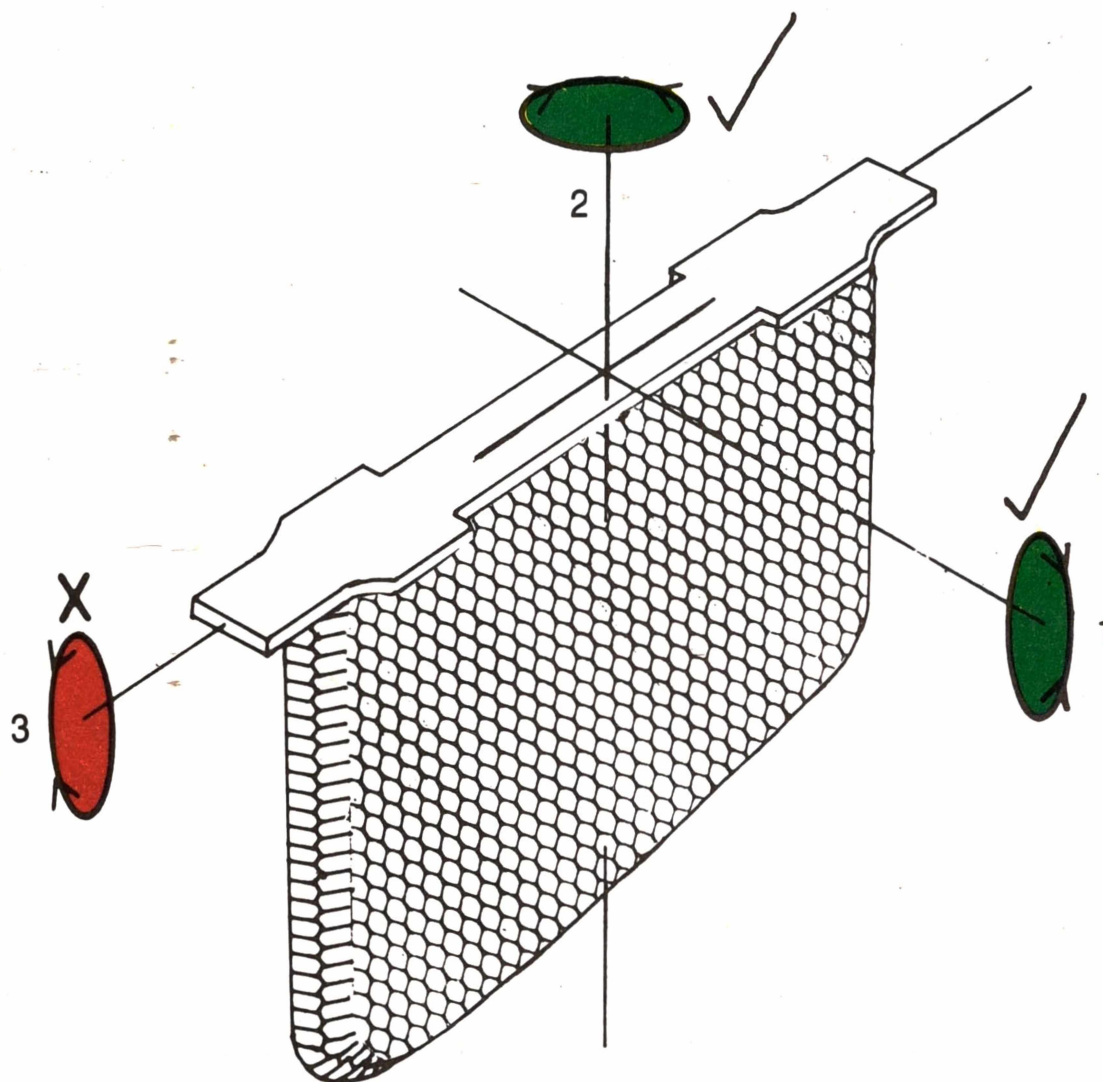

Figure 4.11: Axes through which a comb could be rotated. It is possible to turn the comb in two axes 1 & 2 (marked correct, ✓). A comb should not be rotated through the axis 3 (marked incorrect, ✗) and if this is done the comb will break.

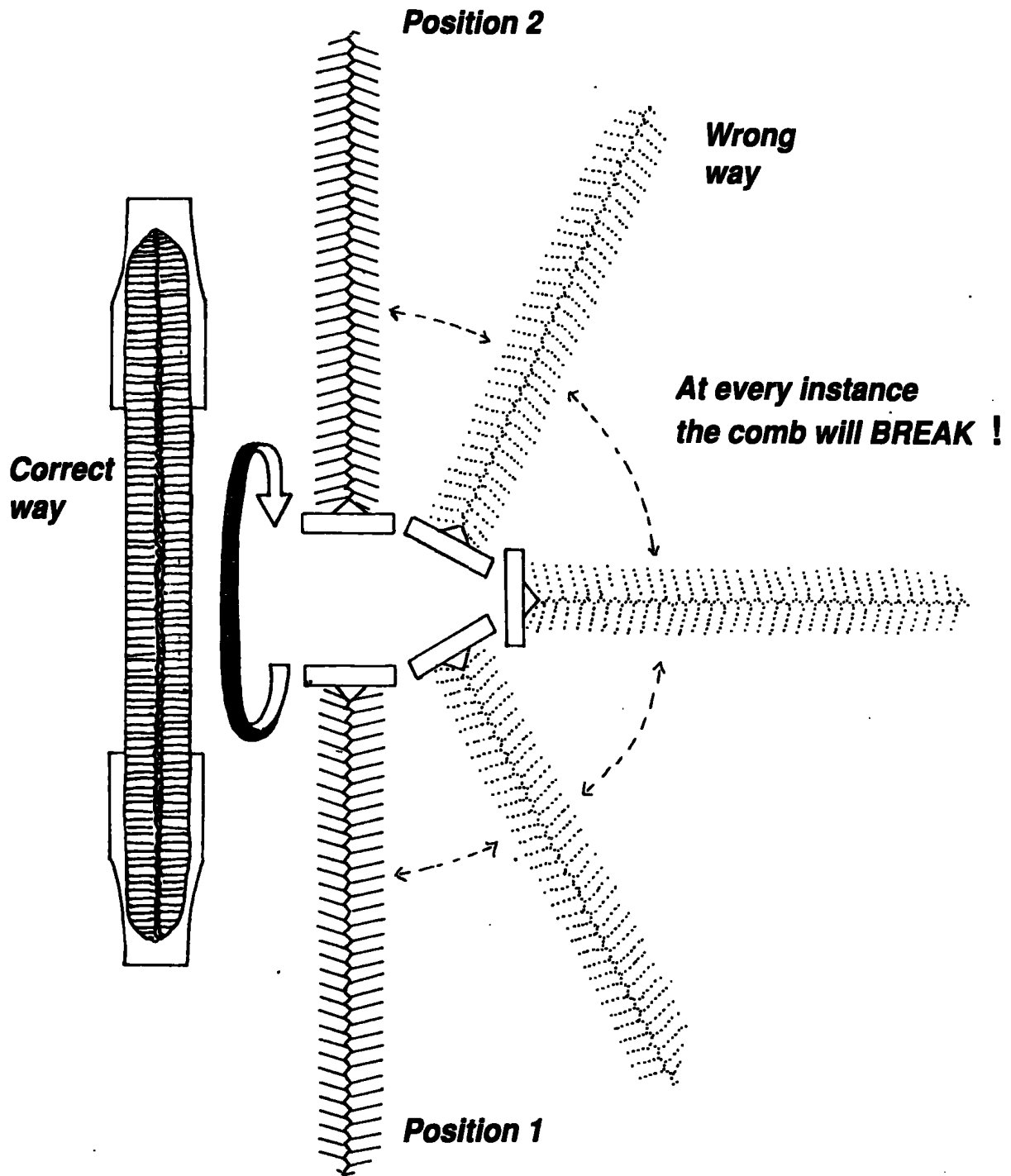

Figure 4.12: Comb is attached to the substrate from the top and hangs down. If the position of a comb built in a frame or a top-bar has to be changed from **Position 1** to **Position 2** or vice versa; it should be turned as shown in the left side of the diagram. It should never be turned as shown in the right side of the diagram as it leads to the breaking of the comb.

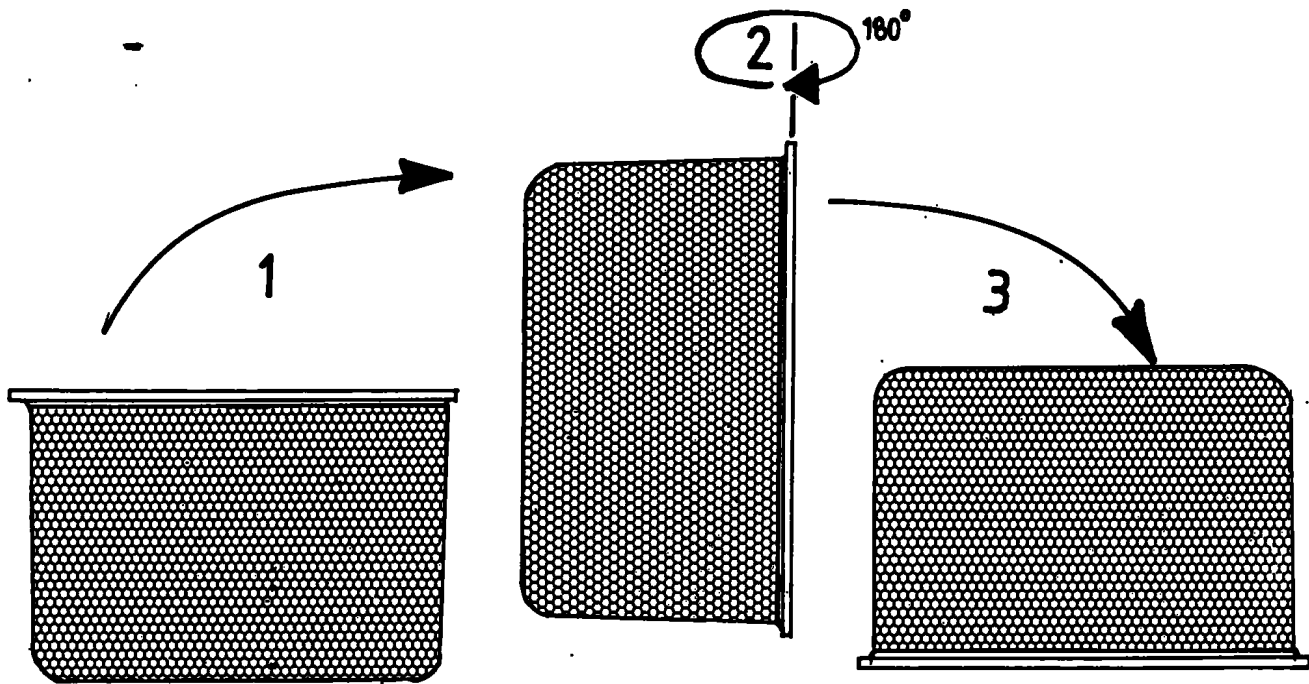

Figure 4.13: When it is necessary to examine both sides of a comb built on a top-bar or a frame; first make it up right (1), then in that position turn it around a half circle or 180^0 (2) to look at the other side or the comb could be inverted (3) from the up-right position or can be examined while in position (2).

4.9. Auxiliary Appliances and Techniques

Table 4.1 gives auxiliary appliances and techniques that were invented since the discovery of “bee-space” in their chronological order and all of them contributed to make beekeeping a large scale industry.

However, the Swiss naturalist **Francois Huber** (1750-1831) is credited with laying the foundation for the scientific understanding of honeybees. Although he was blind, he was assisted by his servant **Froncois Burnens** and revealed many fundamental facts in honeybee biology. (see also Section 10.6.3. 5th paragraph p.198)

Table 4.1: Calendar of inventions that contributed to the development of honey production as a large scale industry.

Invention	Year	Inventor	Country
Effective movable frame (or comb) hive* due to the discovery of bee-space	1851	LL Langstroth	USA
Comb foundation	1857	J Mehring	Germany
Section honey production	1857	JS Harbison	USA
Queens transport by post	1863	CJ Robinson	USA
Centrifugal honey extractor*	1865	F Hruschka	Austria
Queen excluder	1865	A Collins	France
Large scale transportation of queens from Europe to America	1870	A Grimm	USA
Rollers for making comb foundation	1873	F Weiss	USA
Effective smoker*	1875	M Quinby & TF Bingham	USA
Sale of bees by weight	1879	AI Root	USA
System for commercial queen rearing	1883	H Alley	USA
Queen rearing with artificial queen cells	1889	GM Doolittle	USA
Effective bee-escape	1889	EC Potter	USA
Effective system for swarm control	1892	GW Demaree	USA
Transportation of hives to pollinate crops	1895	MB Waite	USA
Wired comb foundation	1920	H Dadant	USA
Successful instrumental insemination	1926	LR Watson	USA

*** Appropriate and could be used effectively in beekeeping in Sri Lanka at present.**



Figure 4.14: A comb broken from the point of attachment to the top-bar due to wrong handling.



Figure 4.15: Fastening the broken comb to the top-bar with the help of Banana fibre.



Figure 4.16: Broken comb temporarily fastened with Banana fibre given back to hive for the bees to mend it properly.

5. Growth of a Bee Population and Management of a Colony

5.1. Natural Growth in a Colony

When one looks closely at the growth of a honeybee colony, one feature stands out clear and distinct. This feature is that in a honeybee colony the growth takes place vertically downwards and side-ways while the combs are anchored on the substrate above. Our hive honeybee or the Mee Bee (*Apis cerana indica*) builds several parallel combs in its nest choosing an enclosed space (see Figure 1.1, p. 5).

The hive honeybee's habit of building several parallel combs in an enclosed space has offered many possibilities for rearing them in enclosed containers such as hives. On examining the nest of Bambara Bees and Danduwel Bees which are exposed it becomes clear that these two species of honeybees will not prefer to build their nests in enclosed spaces (see Figure 1.2, p. 5 and Figure 1.3, p. 6). The growth of a honeybees' nest could be compared in some ways to the growth of a plant in some ways where the plant anchored in the soil grows up-wards (against gravity, towards light) and side ways producing branches. Honeybees' nest grows down-wards (towards gravity) by elongation of combs, which at the same time expand side-ways. Further, the bees make several combs situated parallel to each other which follow the above growth pattern. Figure 5.1 shows the growth of a nest of a swarm of honeybees one week after putting them in a hive and Figure 5.2 shows the same nest 3 months later. Therefore, in the above sense the most distinct difference between a growing plant and the growing nest of a hive honeybee is that the former grows upwards and the latter grows down-wards. For the growth to continue, all other conditions being fulfilled, what is most important is not to have any obstacles to the direction of natural growth. If a growing plant is covered with a sheet of glass, the plant growth would become deformed at the moment the growing point touches the glass. Then what is important in understanding the growth of honeybee's nest or combs is that the growth always takes place in the brood chamber at the bottom. Just as in the case of the plant, the glass sheet becomes an obstacle to its normal growth, the floor-board acts as a restriction when comb building takes place in the brood chamber. It is the floor-board that restricts the growth of combs built on top-bars and in the case of frames being used it is the bottom-bar (also to some extent the two side bars) that become restrictive. Therefore, a comb built in a top-bar is larger than that of a comb built in a frame (see Figure 4.6, p. 69).

By nature, as the combs grow downwards and sideways, the older combs at top become seasoned. The distinctive difference between the old and new combs is that the old combs are dark and strong while the new ones are soft and white. Due to the rearing of bee larvae, the combs get darker and stronger with the deposition of larval remnants and pupal cocoons. By nature the queen prefers to lay eggs on fresh and soft combs and bees prefer to store honey in mature (old) dark combs. Figure 5.3 may give some idea about changes that take place in an old or mature comb compared with a new one.

As the comb grows down wards the bees store honey in the top part which now contains aged combs not suitable for rearing brood.

It is often assumed that the bees will come to honey-super and build combs for the storage of honey. It is only very infrequently that the bee would come to the super and build combs in empty frames. Very often at that point the queen will migrate to these fresh combs and lay eggs in them. Such events take place under high congestion and often it leads to excessive swarming (see Section 6.1 and Figure 6.3).

If one measures the spaces occupied by bees and combs in a "honeybee's nest"¹ some interesting figures would be revealed. Nests such as in Figure 5.1 & 5.2 where the combs are built which is entirely covered by bees, approximately about 70% of the nest volume is occupied by the combs the balance 30% is filled by the bees themselves. Therefore when one refers to the bees' nest it refers to the space where more than two thirds are filled with combs and the rest with adult bees. The space or volume measuring unit "Litre" is used in expressing the nest size or nest space.

To build up comb volume in a nest, provision of comb foundations in empty frames is a suitable solution in situations where the comb foundations are available. But in Sri Lanka direct use of old combs for this purpose in the super is more appropriate.

5.2. Old Combs: An Important Resource in the Management of *Apis cerana indica* in Sri Lanka

It is often suggested that the old combs should be melted down to extract the good wax in them to make new comb foundations² and the old combs are a source of trouble due to the attraction of wax moths (Greater wax moth, *Galleria mellonella*: Pyralidae and Lesser wax moth, *Achroia grisella*: Pyralidae).

Both these may be true if one does not manage the old combs in a profitable way. The old combs yield a very small quantity of wax even when the wax is extracted (with the use of a solar wax melter) very carefully. More over no individual beekeeper is able to make comb foundations themselves. Such wax may find a good market for other purposes such as in the Batik industry.

¹Here honeybees' nest does not mean the empty spaces not used by bees but the space where the combs are built which is entirely covered by bees. The unused space in the nest site should not be considered here, but it is the space that the bees and the combs are occupying. (See also page 8, explanation of nest and nest site)

²With the advancement of the honey production industry due to the invention of the movable comb hive, the comb foundations are used extensively in the effective management of honeybees in the countries with a well developed beekeeping industry. However, for the preparation of comb foundations the equipment for wax extraction, wax sheet making, hexagonal impression making, etc., are necessary and all these require a substantial investment. The scale of honey production industry in Sri Lanka at present does not justify making such an investment. On the other hand the raw material wax has to be obtained in sufficient quantities only through a well developed honey production process. Therefore, only with the existence of a developed honey production industry, the manufacture & supply of comb foundation can take place as a beekeeping supportive service in the future.

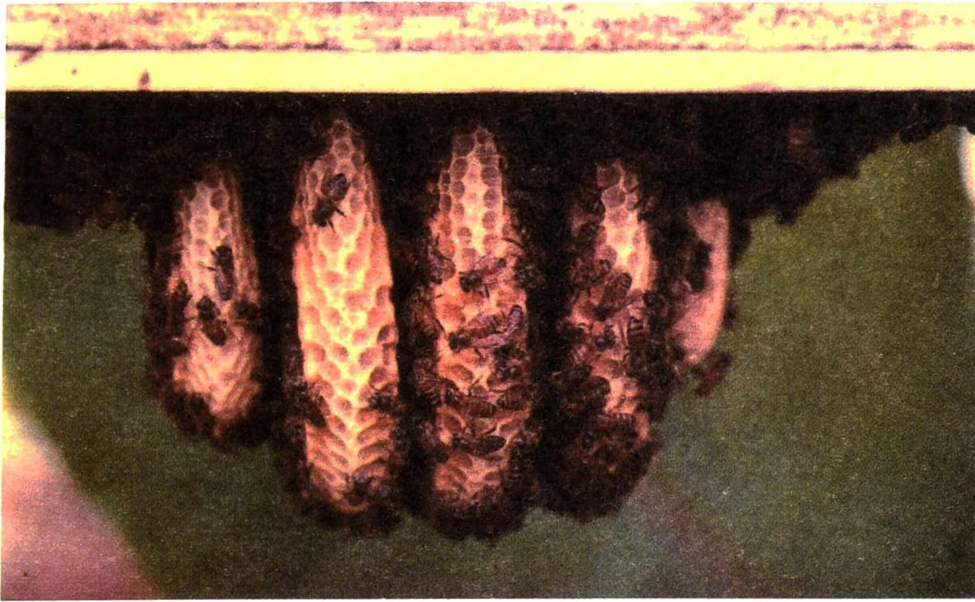

Figure 5.1: Nest size of a young colony which was built by a swarm that was established in a hive one week ago.



Figure 5.2: Same colony in Figure 5.1 three months later.

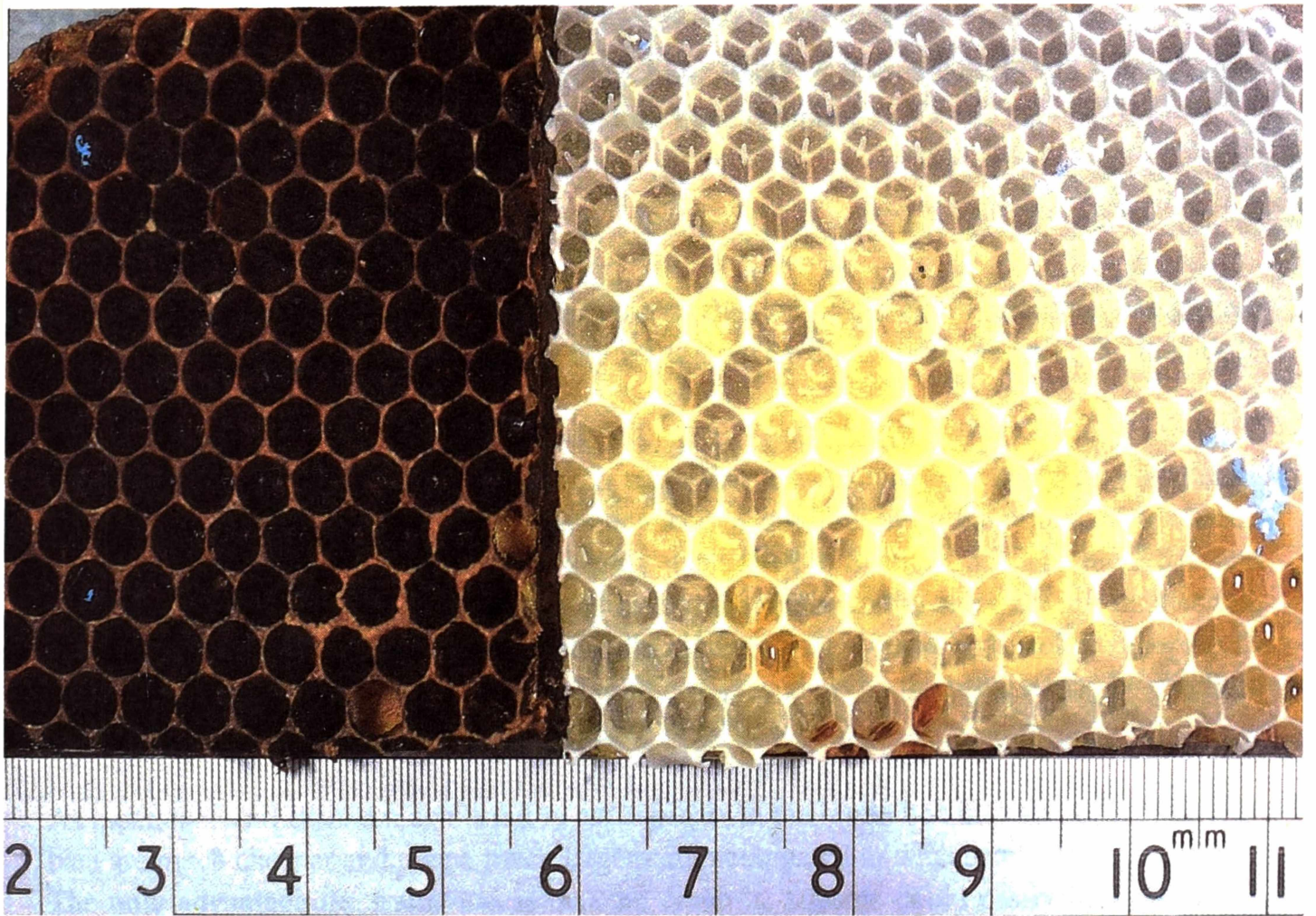

Figure 5.3: Comparison of old and fresh combs. The fresh comb is filled with brood and the strong, dark, old (mature) comb is suitable for storing honey.

In Figure 5.4 & 5.5 the use of comb foundations prepared in two ways is shown and in Figure 5.6 the direct use of a old comb in the super frame is shown. As such it becomes clear that one need not spend time and money to obtain comb foundations and the direct use of old combs are extremely profitable.

Therefore, instead of going through all this hassle one may just use the old combs as they are and find that they are much superior to comb foundations in many respects. For instance:

- 1 Old combs are much stronger than the new combs built on comb foundation.
- 2 In any case comb foundations are very difficult to get in Sri Lanka at present and even if available the price may be high.
- 3 In fact recent findings indicate the bees prefer to store honey in old combs rather than in new ones and it can encourage honey storage.

How to manage old combs

The management of old combs also means the production of old combs and then using them profitably. The combs get older as they are being used by the bees in any case. So how does one remove them effectively ?.

The brood box should be managed in such away that as the combs get older they gradually move to the two sides. It follows that, the new combs are built up in the middle of the brood nest or the brood box. This process is clearly mentioned in Sections 5.3.3.1. to 5.3.3.6. and illustrated in Figures 5.7 to 5.12. If the old combs that come to the sides are left unattended, the bees themselves will shave off these cells rendering the combs less useful. Figure 5.13 shows an old comb left unattended in the brood box shaved off by the bees. It may be that bees need to get rid of the old combs to find space to build new ones.

As mentioned earlier, it is much better to use top-bars in the brood box instead of frames. Top-bars are much cheaper and give a much larger comb compared to what can be built in a frame. The only advantage the frame has is that the comb in a frame could easily be kept on the ground without damaging the comb and the two side bars and bottom bar may give some protection to the comb inside. But in good beekeeping, this protection is not necessary for brood combs.

Once the brood comb is old and has taken a position on one side, it is ready to be transferred to the super to collect honey during the honey season. The old or mature combs systematically transferred to the honey frames will provide honey storage space during the honey-flow.

5.3. Population Management

What we mean by population management is the establishment of a sufficient population of foraging bees to collect the nectar effectively from a potential honey-flow. Here then an important question proposes: how many bees should one have in a colony ?. In Sri Lanka to produce a quantity of honey between 1 to 2 kg, there should be at least about 15,000 bees or a nest size of about 12 liters.

Further, as discussed in Section 2.1, the 3rd prerequisite for honey production, is the population size. This is the only factor under the complete control of the beekeeper.

The Figure 5.14 is presented to illustrate the importance of the population size for honey production from a honey-flow which lasts for about 4 to 6 weeks. In Figure 5.14, Curve 1 depicts what usually takes place with many colonies and with many beekeepers. It is quite common that just at the beginning of the honey-flow, the colony starts to swarm. The colony build-up on the nectar availability during the pre-honey-flow period is such that by the time it reaches the honey-flow there is much congestion and the colony breaks up or begins to swarm out. In such an instance beekeepers get nothing or very little from the honey-flow.

A good indicator of congestion in the hive is the appearance of clusters of bees in the under-side of the inner cover. This indicates that there are more bees than the available comb space as shown in Figure 5.15. On the other hand having a single layer or a few bees on the inner side of the inner cover is in fact very desirable and this indicates that the bees are actively covering the periphery of the nest, as shown in Figure 5.16. In such an instance the comb area and the bee population have reached an equilibrium.

The Curve 2 in Figure 5.14 indicates that swarm management was timely but that the build up was insufficient during the growth phase to get an adequate population. Such colonies will fill up to the 2nd super (about 16 liters nest size). This normally happens in colonies where the supplementary feeding was insufficient during the growth phase.

The Curve 3 in Figure 5.14 indicates a colony well managed by timely supplementary feeding and swarm management where it was able to build up beyond 4 supers. Beekeepers should aim at managing colonies so as to get high populations as the colony illustrated in Figure 5.17.

For building up colonies of good strength, it is essential to have the following requirements:

5.3.1. A Prolific Queen With a Good Egg Laying Ability

It is thought essential and is in fact often the practice to examine the colonies every now and again. In fact some even question how often the colonies should be examined and the frequency. One important aspect or perhaps a ritual of such colony examination is to look for the queen to find out her condition. There is nothing wrong in seeing the queen. But just by looking at her it is not possible to say how good or bad she is !.



Figure 5.4:

When wax sheets turned out from the wax extracted from old combs were marked with irregular impressions and given to colonies the bees start making irregular cells. J. Mehring in Germany made the first comb foundations in this manner in 1857. (see Table 4.1)



Figure 5.5:

When a regular hexagonal impression is made on wax sheets with a machine the bees build regular cells on them. F. Weiss in USA made the first machine impressed comb foundation in this manner in 1873. (see Table 4.1)



Figure 5.6:

However it is more appropriate to use older brood comb directly on to Honey Frames in Sri Lanka at present. This could be easily done and costs almost nothing.



Figure 5.7: Removal of mature (old) comb from one end of the brood box.



Figure 5.8: Clearing the bees from the mature comb built on a top-bar by clamping it onto the hive entrance. The bees are getting back to the brood nest. Use of a little smoke may hasten the process.

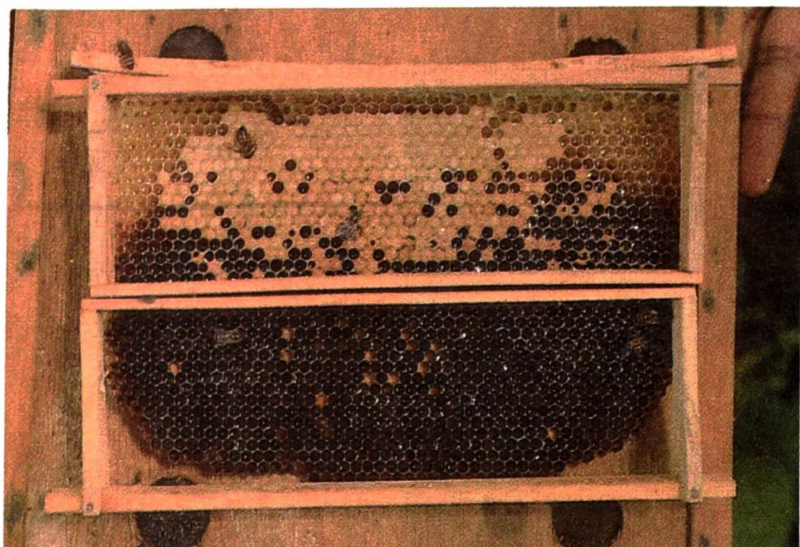

Figure 5.9: The mature comb is enough to cover the comb area of two honey frames.



Figure 5.10: The mature comb is cut into the appropriate size to fill two honey frames.



Figure 5.11: An empty space in the middle of a brood chamber is obtained by sliding the combs. This space is now provided with a Top-bar to build a new comb.



Figure 5.12: The two honey frames fitted with mature combs given to the first honey super right at the middle. **Utilization of a valuable resource.**



Figure 5.13: An unattended mature comb left in the brood chamber shaved off by bees. **A resource being wasted.**

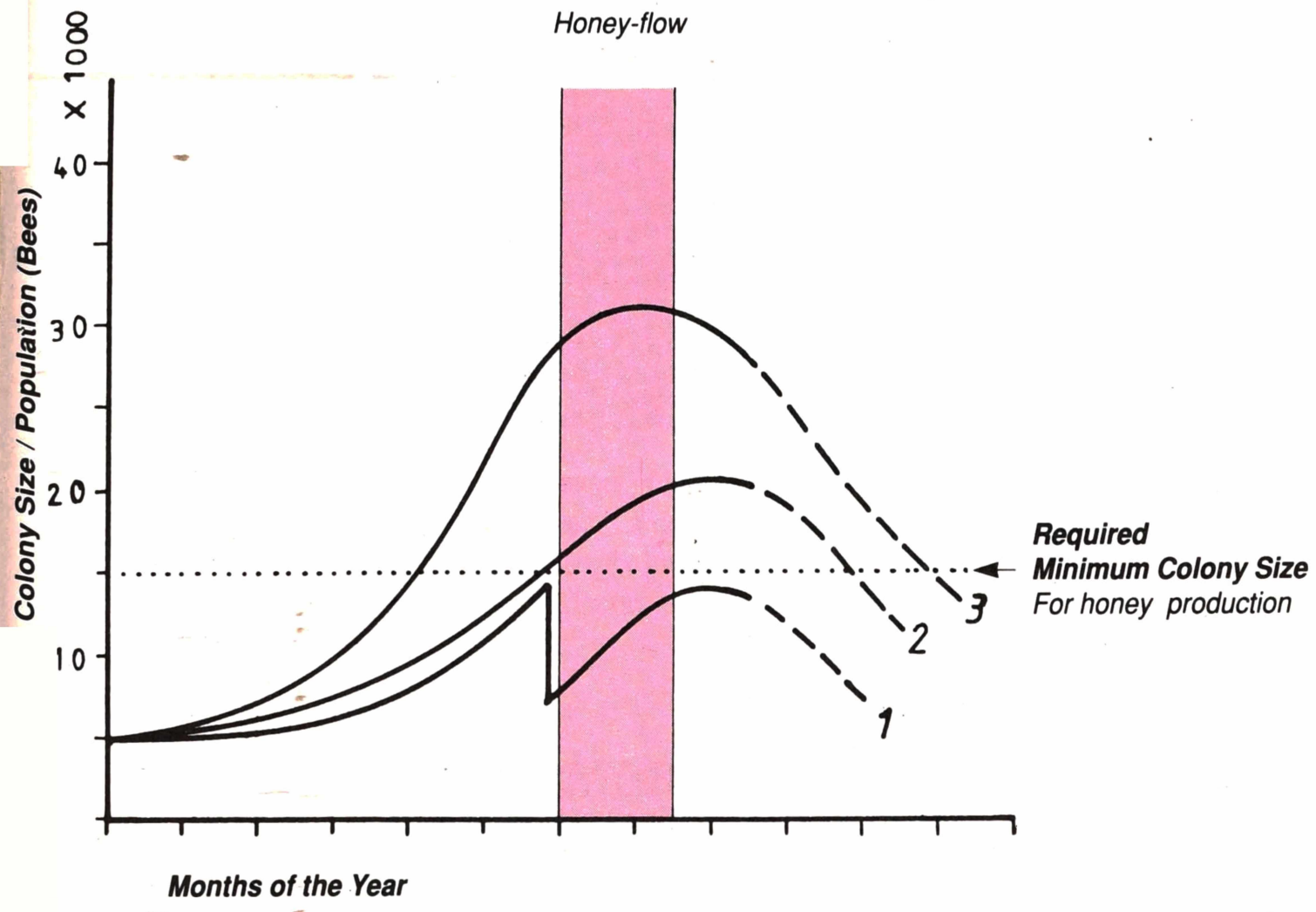

Figure 5.14: Different colony growth rates and population sizes to synchronize with the honey flow. Curve 1 illustrate the impact of swarming. See Sections 5.3 & 6.1 for details.

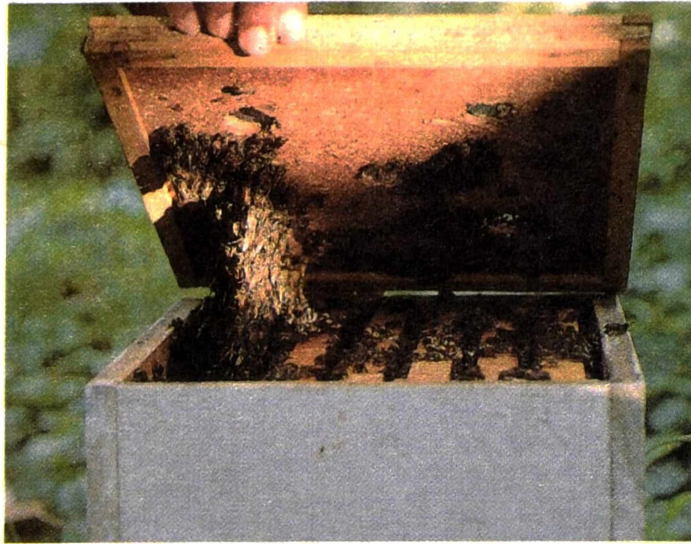

Figure 5.15: Clusters of bees hanging in the inner cover is a good indicator of congestion in the hive. These clusters of bees need more comb space to spread out.



Figure 5.16: A single layer of bees on the inner cover is indicative of a proper balance of bees and necessary comb space in the nest.

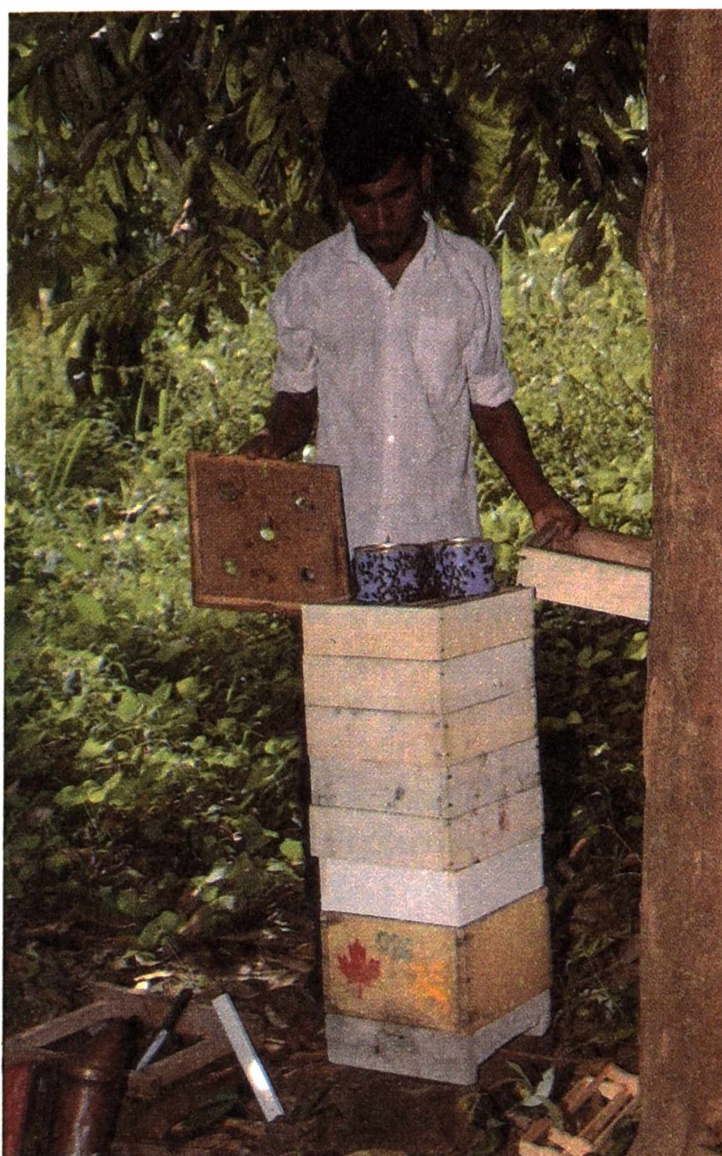

Figure 5.17: A well managed colony with 6 supers full of bees. Such colonies will yield well during the honey-flow. The feeders (blue coloured cans on top) were used to feed them during the growing period.

In Figure 5.18 is shown a brood comb with bees and the queen. Can you spot the queen ?. Of course, one has to have some kind of experience in spotting the queen and any one familiar with bees should have this ability. The queen can be anywhere in the 8 combs of the brood box. One is lucky if she happens to be in the first comb one pulls out. Otherwise a considerable amount of time would have to be spent in looking for the queen and as a matter of fact nothing of practical value is gained by just seeing her. So what amount of time would you like to spend in looking for the queen ?. The strands or chains of bees which could be easily seen when a brood comb is slid away from another in a brood chamber is a better indication of a healthy colony, as in Figure 5.19. These bee strands indicate that bees are busy building combs.

It is more important to see the functions of the queen rather than merely to see her. If one happens to see her by accident, it is well and good. What are her functions ?. In beekeeping for honey production she is only an egg laying machine, whose eggs give rise to workers who gather nectar to produce honey.

The conditions of the newly built combs in Figures 5.20 & 5.21 show the brood stages to look for in a comb to see the condition of the queen. As long as there is a brood (eggs, larvae and pupa) obviously the condition of the queen is good !. So one can leave her alone but one must make sure she continues to lay uninterruptedly. Just seeing large areas of eggs is a reliable indicator of the presence of the queen and that she is functioning well. For this the necessary management practices are given in detail in the sections to follow.

The only instance one has to look for the queen deliberately is when she is needed to be caught and/or removed. There are two such occasions in practical beekeeping.

- 1 In colony dividing for swarm management prior to the main honey-flow. This aspect is discussed in detail in Chapter 6.
- 2 If the colony gets the absconding impulse firmly established and it becomes necessary to remove the impulse. This aspect is discussed in detail in Chapter 7. But if colonies are managed properly, this is not a necessity.

5.3.2. Provision of Sufficient Space

5.3.2.1. Space Requirement Depending on the Growth

Space requirement depending on the growth of the colony can be categorized as follows:

- 1 Space for uninterrupted egg laying for the queen.
- 2 Space for expanding population of adult bees.
- 3 Space for honey storage.

Provision of extra space (empty) for a small colony of honeybees will impose difficulties in temperature regulation in the brood nest and make the colony vulnerable to intruding pests. Therefore the supply of space should be in accordance with the existing requirements of the colony. It is also very important to remember that space for the colony does not mean simply empty space but implies comb area or comb space or the nest volume.

In the present movable-comb-hive, to alter the space of the brood nest the “Dummy Board” could be used. By removal or addition of supers, frames or frames with combs, the other space could be controlled.

Population and comb space management in a nest of honey bees in a movable-comb-hive becomes crucial since by trying to rear them in the hive we have imposed some impediments to their natural growth. (see Section 5.1) Unless these impediments are removed in time and their natural growth process is harnessed the results will be disappointing.

In a movable-comb-hive we are expected to maintain the brood nest at the bottom and honey supers on top. This perhaps should be the final arrangement at the time of harvesting honey. In any case in a movable-comb-hive we start at the bottom with the brood box and then the downward growth is rather restricted. So clever beekeepers will have to make provision for uninterrupted growth at the brood nest and also ensure the availability of combs for honey storage in the supers. This could be achieved by planned and systematic transfer of older brood combs to the supers.

5.3.2.2. Space Requirement Depending on Environmental Conditions

In this regard the space requirement could be divided in to three categories as follows:

- 1** Space requirement during the Growth Phase.
- 2** Space requirement during the Honey-flow Period.
- 3** Space requirement during the Dearth Period.

5.3.3. Population Management During the Growth Phase

Bee population management parallel with the comb management is described in 35 stages in the sections to follow. The symbols and abbreviations used in these stages are explained in Figure 5.22.

It is also important to understand that, even though the inner cover is indicative of the upper boundary of the nest, the inner cover need not be always immediately above the upper boundary. For instance, if it was necessary to feed the colony, it is quite obvious that one has to add another empty super to keep the feeder, where the inner cover will be on top of the added super rather than on top of the actual nest, as illustrated in Figure 5.23.



Figure 5.18: A brood comb with worker bees and queen. How fast can you spot the queen ?. Note that on a comb the bees are not stationary, unlike in this picture. Project arrows inside to locate the queen. The "court formation" is somewhat disturbed as the comb was kept outside for a long period.

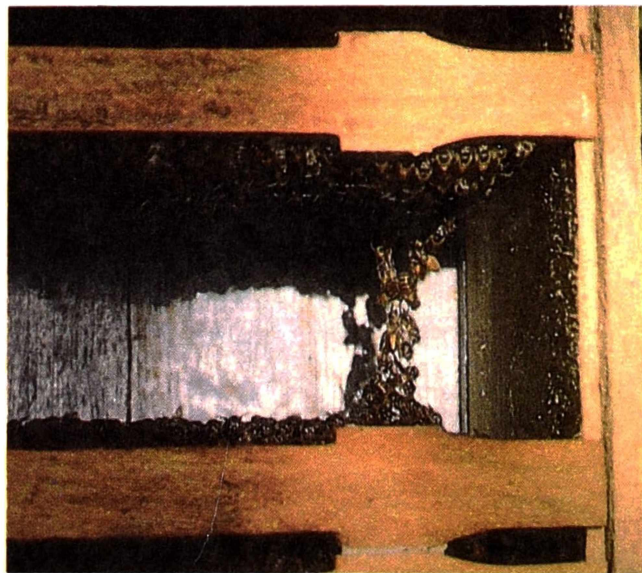

Figure 5.19: The condition of a colony could be judged by seeing this kind of bee-chain when the hive is opened. This is more indicative of a healthy colony than can be inferred by observing the queen.

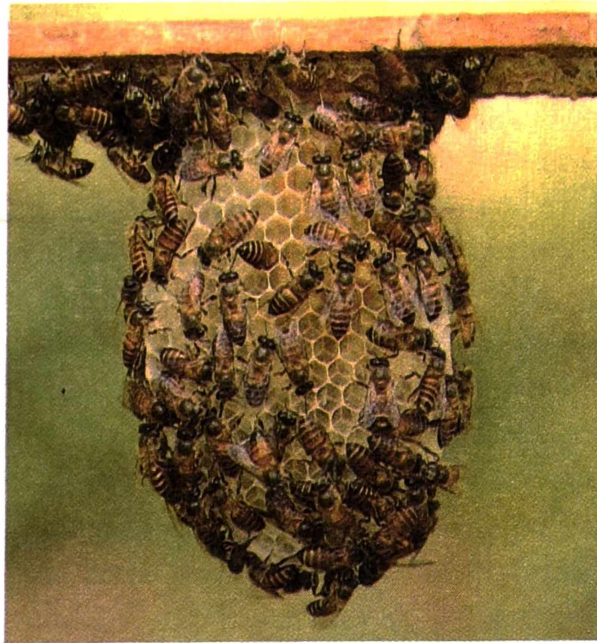

Figure 5.20: Bees have just started to build a new comb. This much of comb growth should be achieved in 3 days if the food supply is good. The queen has already laid a few eggs.

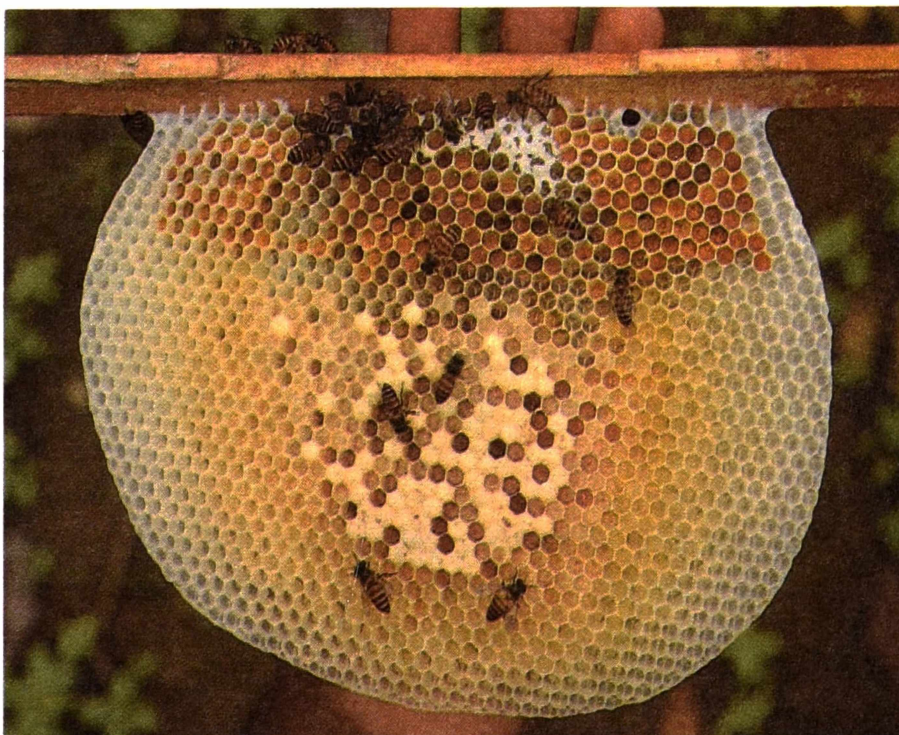

Figure 5.21: A comb which has grown to 50% of the full size on a top-bar. This indicates that another empty top-bar space could be given for further growth. Compare with Figure 5.25 (p.103).

5.3.3.1. Initiating Growth

Consider a small colony of bees with just two brood combs. This small colony is given a small nest space with the use of the dummy board and it is kept just next to the two combs. It is important to know whether this small colony is growing and the best way to find out is by allowing it to grow. We can allow it to grow by providing an empty space (an empty frame or a top-bar) on one side of the two combed brood nest (Figure 5.24, stage 1). If the food supply is sufficient it should grow. Once an empty space is provided by means of an empty frame or a top-bar, bees should start to build in this new space. This would become obvious in a few days and one can re-examine this in about 7 to 10 days after the space was given. If it is growing the bees would have started building combs in the space provided. The Figure 5.25 illustrates the various stages and respective sizes of the comb built up in a top-bar. One should be able to judge the size of the comb just by having a cursory glance at it. If the bees are not interested in building new combs, it means that they do not get enough nutrition for growing. Therefore, at this point one has to provide supplementary food for them to grow. If the colony is growing, one may allow it to build at least a 50% comb coverage in the new space (Figure 5.24, stage 2). A 50% grown comb was shown in Figure 5.21. Once it has reached this expected growth level, one should transfer this newly built comb to the middle of the brood nest while providing another empty space where the shifted comb was earlier (Figure 5.24, stage 3). Compare the 50% grown comb in Figure 5.21 with the completely grown comb in Figure 5.26.

All the above manipulations have to be done with minimum disturbance to the colony. In fact, one need not disturb the colony at all. This being such a small colony the use of smoke may not be necessary (depending on the beekeeper). All the operations and observations can be done just by sliding the dummy board away from the brood nest. The only time any disturbance is going to take place is when the 50% grown new comb is shifted to the middle of the brood nest. But this also could be kept at a minimum level. These operations have to be done swiftly and carefully. The time period that is necessary for a comb to grow to a 50% level cannot be given. At this initial stage, it may take a week or a few weeks. It all depends on the food supply. Therefore for initiating growth it is highly desirable to give them supplementary feedings.

Like in the earlier case, watch for the comb growth in the second empty space given. Once this has grown to a 50% level transfer it to the middle of the brood nest as before (Figure 5.24, stages 4 & 5). Now we have 4 combs in the brood nest, two older and complete ones on the sides and the new growing ones in the middle. Compare the completely grown comb in Figure 5.26 with growth stages in Figure 5.25. In general, it should take not more than a month for a freshly built comb to come to this size. Now we have initiated the growth of the colony and it may be reiterated that if environmental food supply is limited, it is imperative to give it supplementary feeding to maintain the growth level. As a general rule, the colony should have come to a four brood comb stage in about 6 weeks or less.

Action to be taken

Arrows indicate the change in position of super frames with combs after supplying the old brood combs to them

Supply of an old brood comb to two super frames at the middle

End brood comb to be supplied to super frames

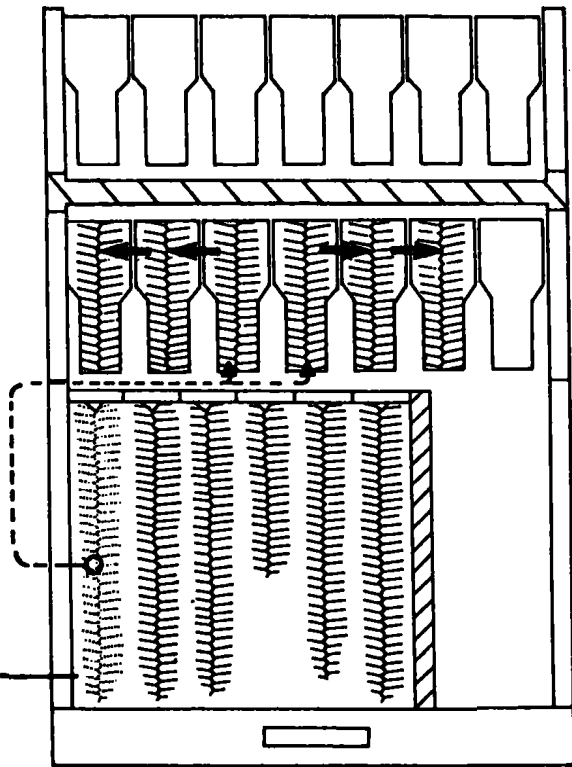

Condition of the hive either before or after the action has been taken

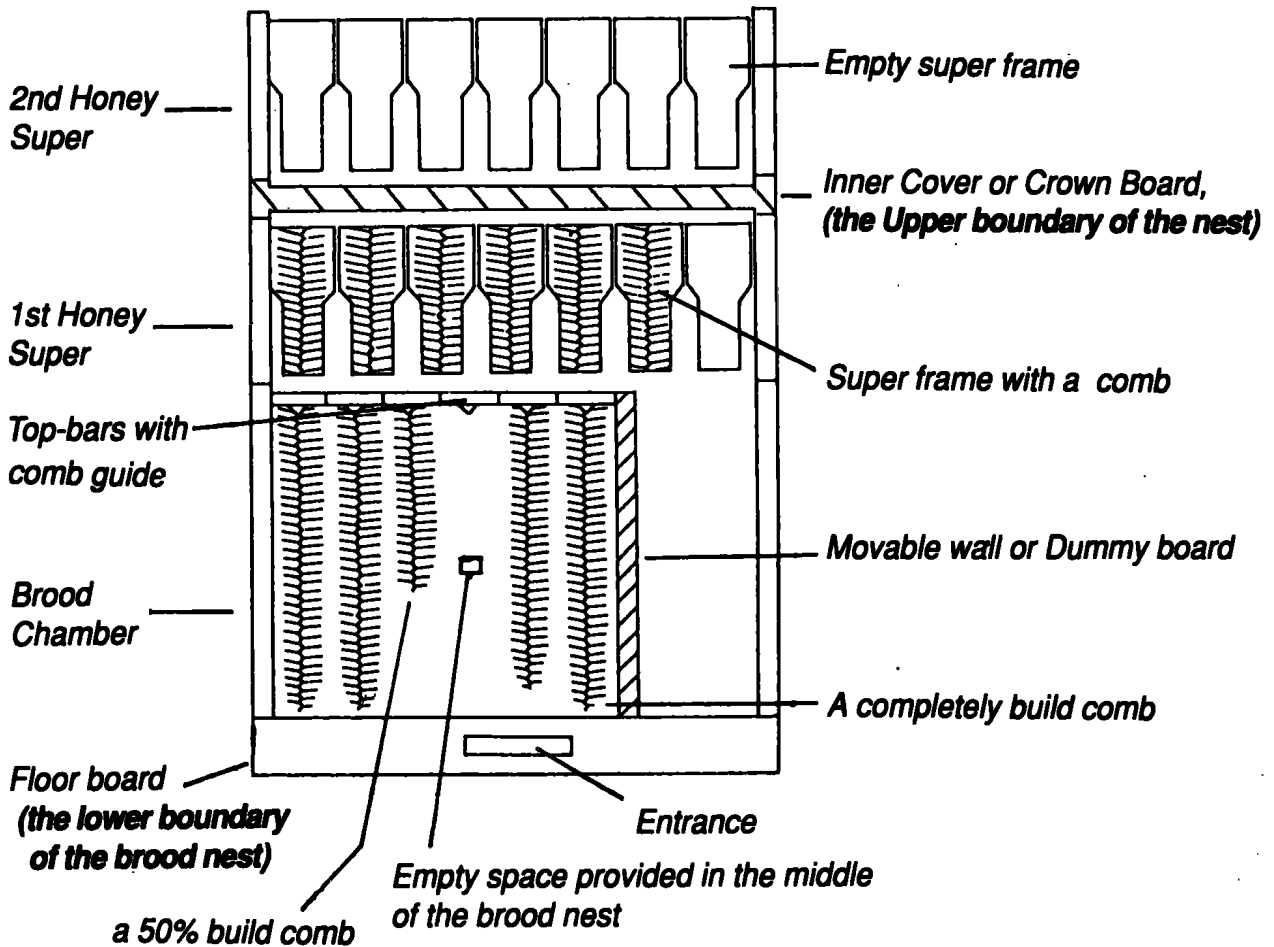

Figure 5.22: Explanation of the steps to be followed in the management of a nest of honeybees in a hive (roof not shown, only the hive parts containing the nest is shown).

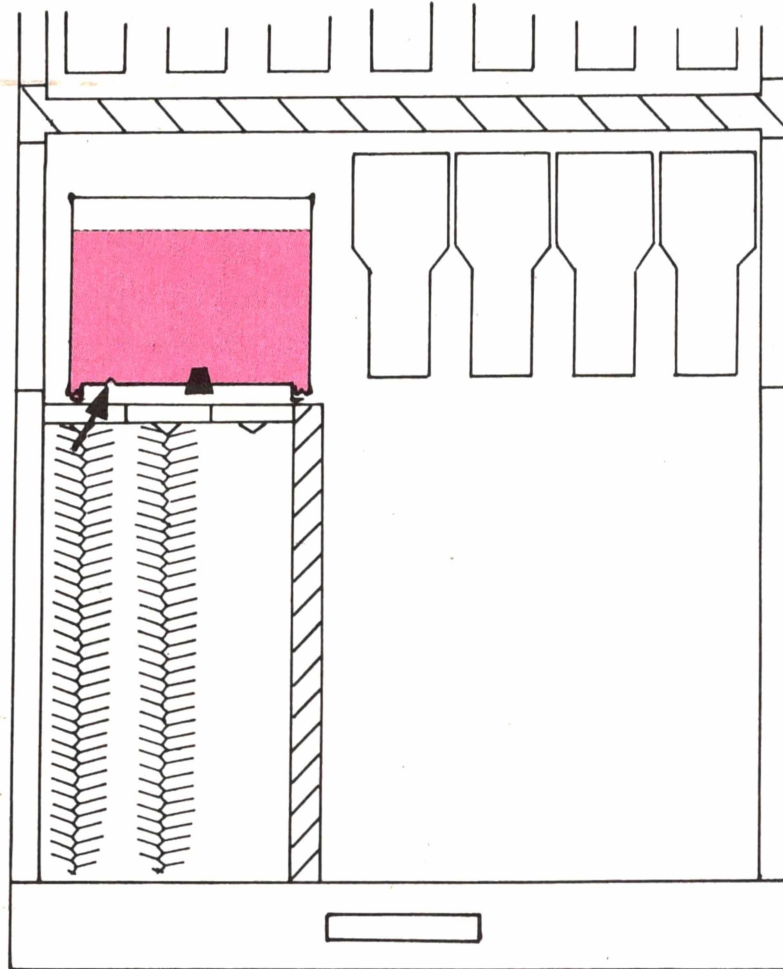

Figure 5.23: The position of the feeder and inner cover when it is necessary to do supplementary feeding. It is important to place the single hole in the feeder just above the nest (note the arrow “↑”).

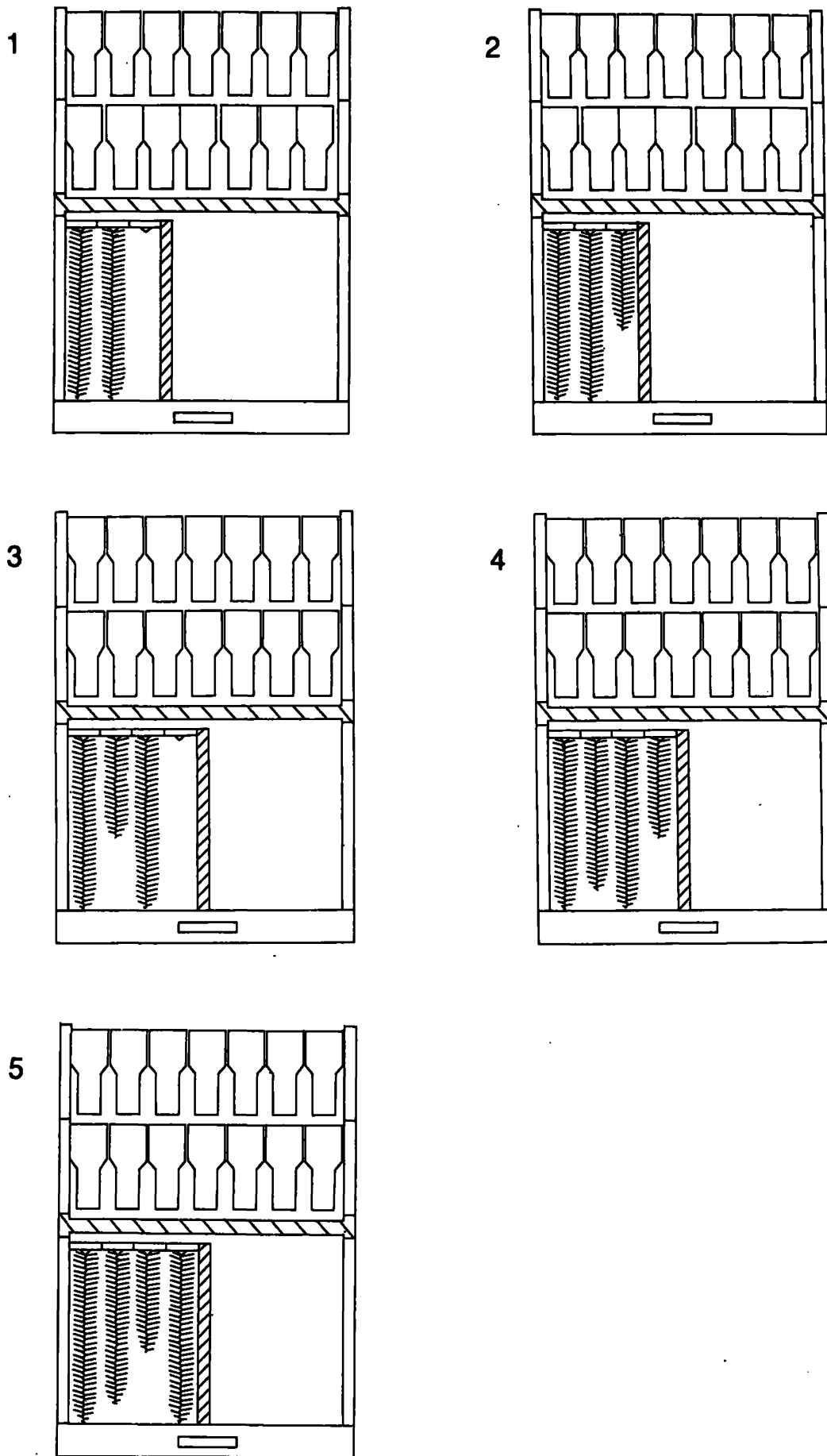

Figure 5.24: Initiating the growth of a small colony of 2 brood combs up to 4 combs in the brood chamber. Stages 1 to 5.

5.3.3.2. Continuation of Growth to Six Brood Combs

Once the growth is initiated and the colony brought to a four brood comb stage, we should continue to maintain its growth. Now we can introduce an empty frame or a top-bar right in the middle of the brood nest unlike earlier where we initiated it from a side (Figure 5.27, stage 6). As there is a sufficient population now, making an empty space in the middle of the brood nest will not create any difficulty to the bees. Providing an empty space in the middle of the brood nest will encourage the bees to draw the combs faster. Ideally the bees should draw the comb to a 50% stage in two weeks or less. This growth process is continued till the brood nest gets 6 brood combs by adding another empty space in the middle if the previous one has reached the 50% comb stage (Figure 5.27, stages 7, 8 & 9).

5.3.3.3. Expanding the Nest to the First Super

Once the brood nest has reached the 6 comb stage (Figure 5.27, stage 9) any growth beyond this should be utilized to build up the first super. It is done in the following manner. The oldest comb on one side of the brood nest is removed and this is cut up into two and fitted on to two super frames (Figure 5.28, stage 10 see also Figures 5.7 to 5.12, pages 88~90). At the time of this transfer, the brood comb may have honey and pollen stores as well as some brood. But one need not worry about the brood on the comb. What is more important is to expand the nest to the super by supplying an old brood comb to two super frames. These two super frames should be placed directly above the brood nest and in the middle position.

In the brood nest now there are only 5 combs remaining and one top-bar (or empty frame) should be inserted in the middle as before for comb building (Figure 5.28, stage 11). This process should be continued keeping the number of brood combs at six until at least six super frames are complete with combs or three brood combs are transferred to the supers (Figure 5.29, stages 12 to 16).

5.3.3.4. Expanding the Brood Nest to Seven Combs

Once the first super is supplied with 6 frames with combs the further growth in the brood nest should be kept to expand the brood nest itself and these stages are explained in Figure 5.30, stages 17 to 20).

5.3.3.5. Expanding the Nest to the Second Super and Completion of Two Supers with Combs

Once the brood nest consists of more than 6 brood combs (stage 20 in Figure 5.30), the oldest comb in the brood chamber should be supplied to the super frames again. Here this comb is supplied to the middle of the first super and it is from the first super that two existing comb frames are supplied to the second super. The comb transferring process is explained in Figures 5.31 & 5.32, (stages 21 to 30) until the completion of all 14 frames in the two supers.

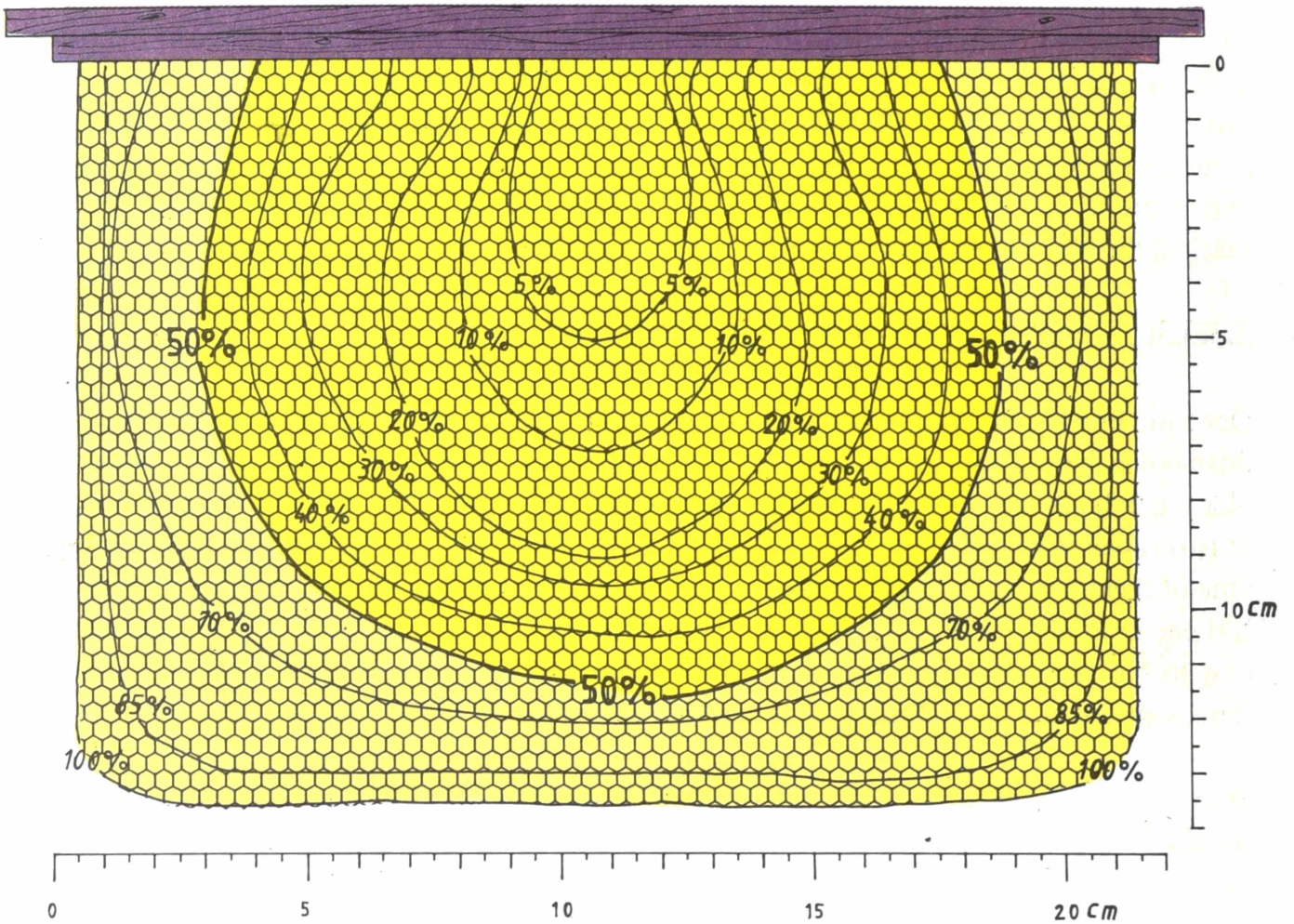

Figure 5.25: Various stages and the respective sizes of a comb growing in a top-bar. To know the 50% growth level is important to give another free space to build up the next comb. Compare with Figures 5.20, 5.21 (p.97) & 5.26 (opposite).



Figure 5.26: A completely grown comb. There are about 450 bees on this comb. The ability to make a quick estimate on the number of bees on a comb is important in colony dividing (see Section 6.3, self-regulating colony dividing method, p.130 & 133-134) Compare with the different growth stages in Figure 5.25 (opposite).

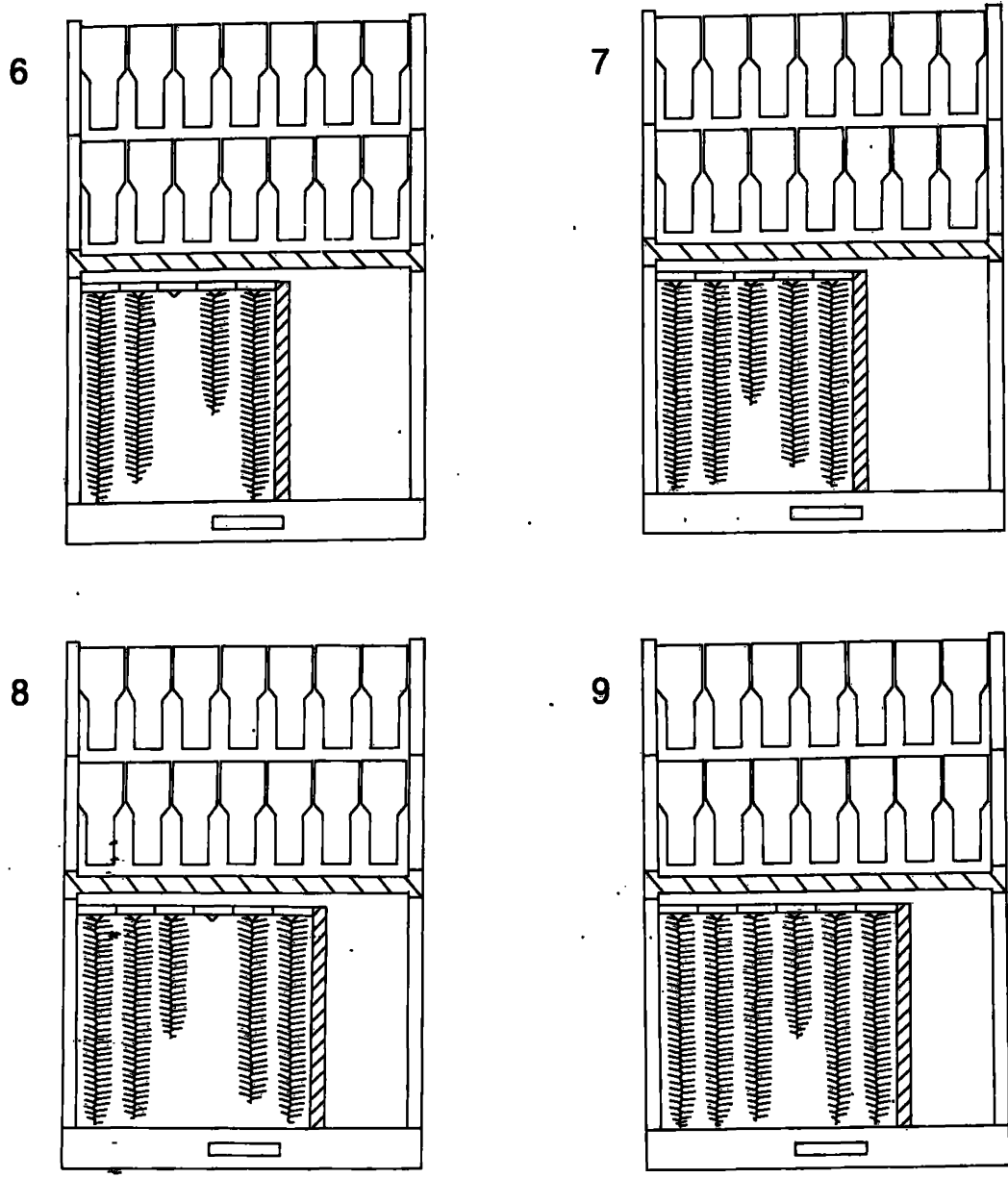

Figure 5.27: Maintaining the growth up to six brood combs in the brood chamber. Stages 6 to 9.

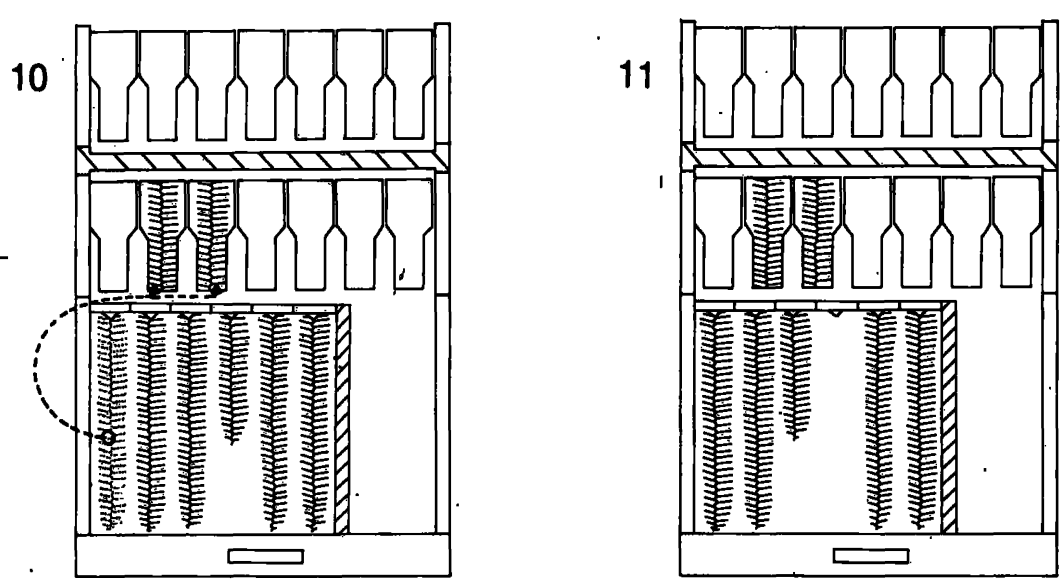

Figure 5.28: Expanding the nest to the first super. Stages 10 & 11.

In this process it is not desirable to transfer the end combs of the brood nest directly to the frames in the second super. Instead they should be given to the middle part of the first super and comb frames from the first super should be given to the second super. This is especially important as some of the end frames coming from the brood box may still contain some brood stages thus requiring the attention of nurse-bees. Nurse-bees are always in the brood nest area and will not migrate up to the second super to attend to the brood combs transferred there for super completion.

5.3.3.6. Completion of the Brood Chamber

Once the two supers are provided with the full complement of frames complete with combs the next step would be to allow the brood nest to grow to eight combs stage as explained in Figure 5.33, stages 31 to 34.

5.3.3.7. Rapid Growth Phase Prior to the Honey-Flow

Rapid growth period is imminent just before a honey-flow and may take place about 4 to 6 weeks before the real flow period. This will be the time for re-queening and preparation of the colony for the honey-flow. By the time the colony is exposed to the honey-flow it should have at least two supers complete with combed frames. If the growth was rapid enough in the earlier stages to fill the second super the beekeeper will have less worries. But he or she may plan to complete a third super and can conveniently achieve this if the colonies had desirable growth levels (see Figures 5.14, 5.17 and Section 5.3).

Another common phenomenon that takes place during the rapid growth phase is the production of drones just prior to raising of new queens in preparation for swarming. The insertion of an empty frame or a top-bar in the middle of the brood nest will greatly facilitate the building of drone combs to rear drone brood. The appearance of drone brood (as illustrated in Figure 6.4) is a very timely indication of the events that would take place in the future and the beekeeper shall plan for swarm management and multiplication of colonies. Swarming and requeening is discussed in Chapter 6.

5.3.3.8. Optimum Size of the Colony

It is often asked what the best size of a colony should be for optimum honey production. The question presumes that the honey yield always depends on the size of the population of the honeybee colony. This presumption is correct (see Section 2.1). But it may be added that the growth achieved before the honey-flow is the factor which determines the size of the population during the time of the honey-flow. The growth is determined by the food supply, natural or artificial. This again is a difficult question to answer and it all depends on the growth achieved by the colony before the honey-flow. Therefore whenever natural food supply is lacking feeding becomes an important issue in determining the size of a colony and in Sections 7.6 & 7.7 this aspect is discussed in detail. A large colony with up to 6 supers could be made easily with supplementary feeding and planned comb transferring.

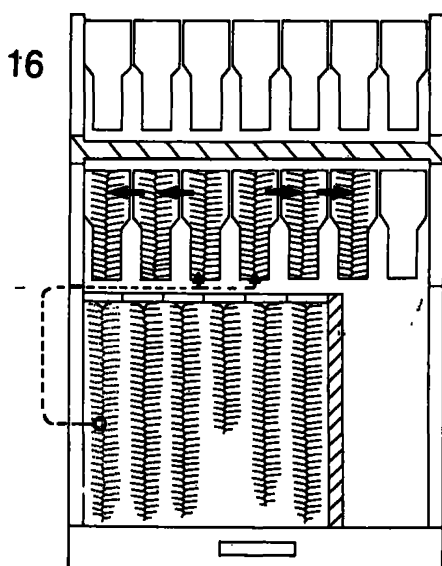
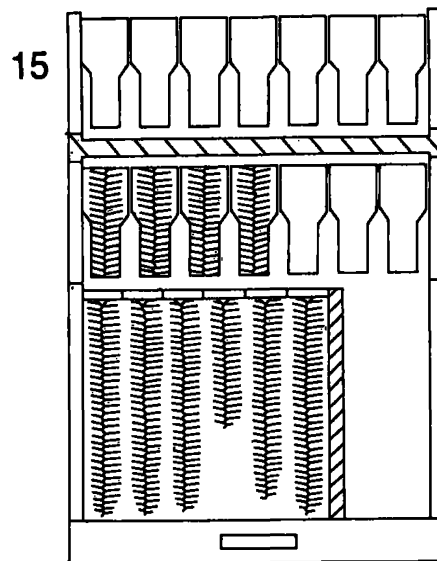
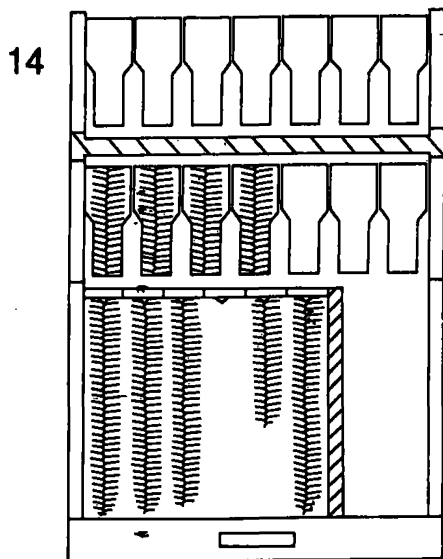
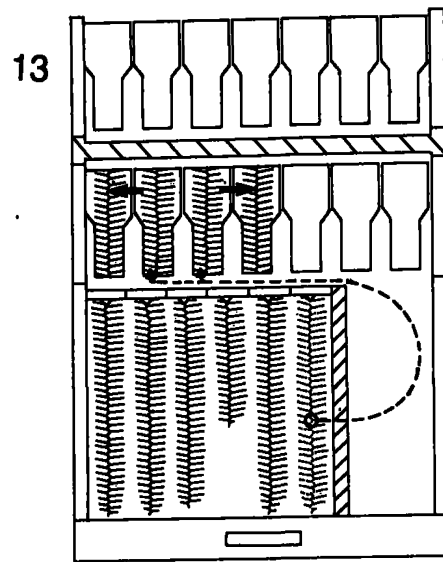
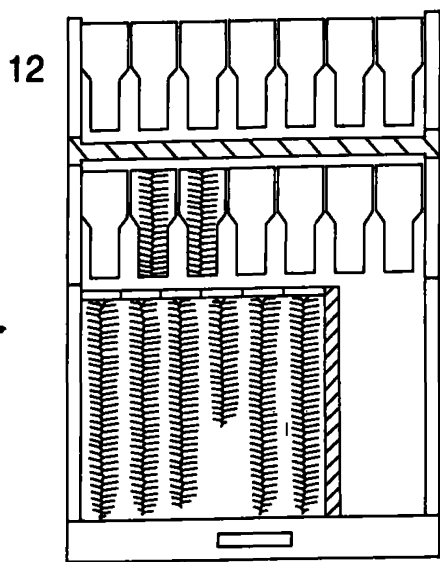

Figure 5.29: Expanding the nest to the first super. Stages 12 to 16.

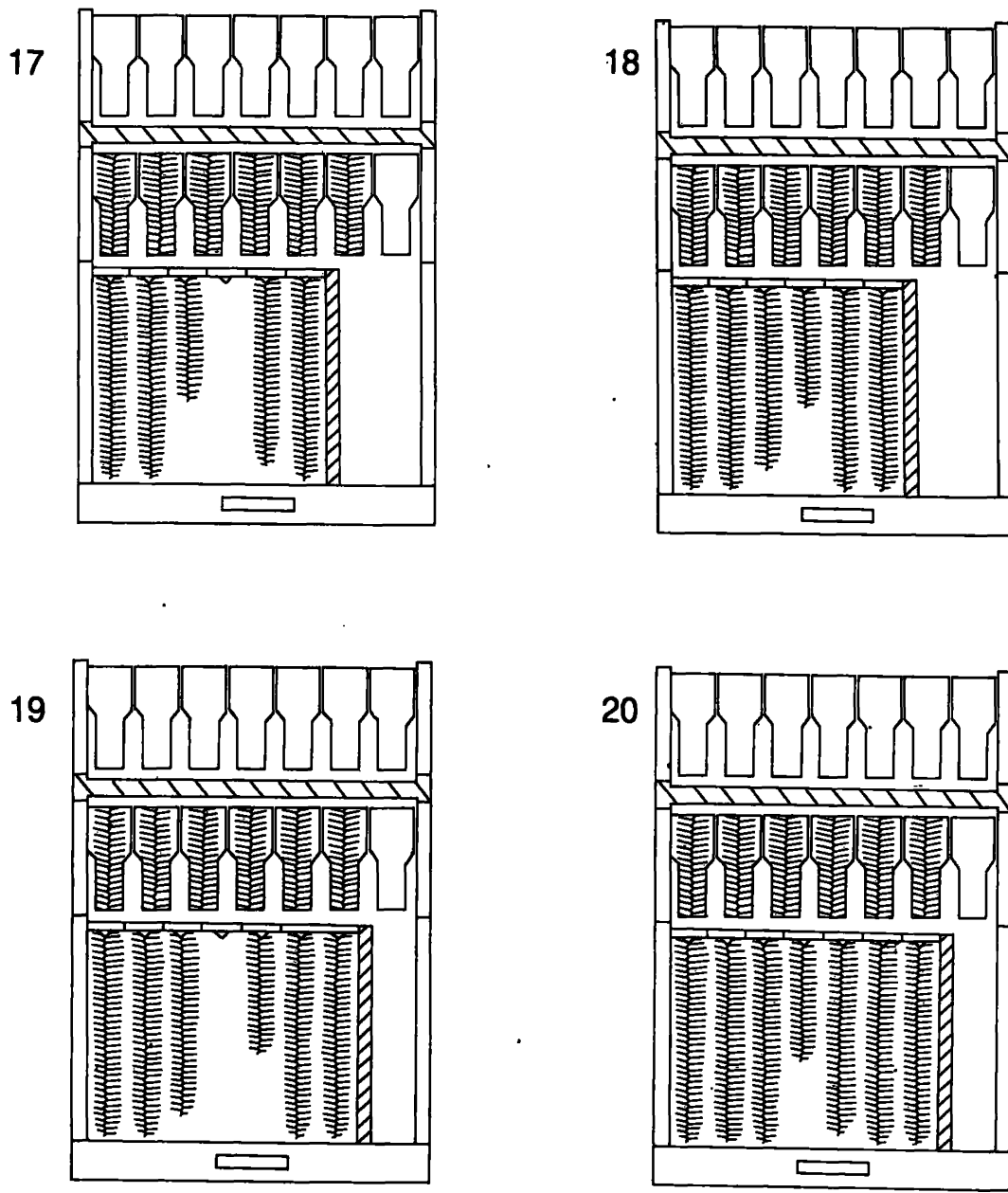
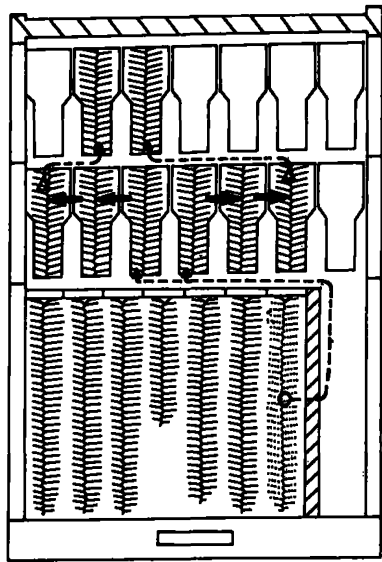
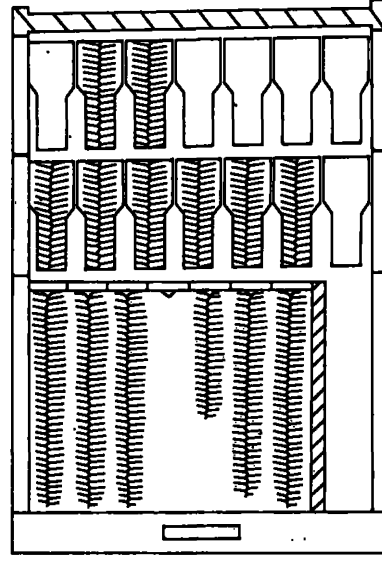

Figure 5.30: Expanding the brood nest to seven combs. Stages 17 to 20.

21



22



23

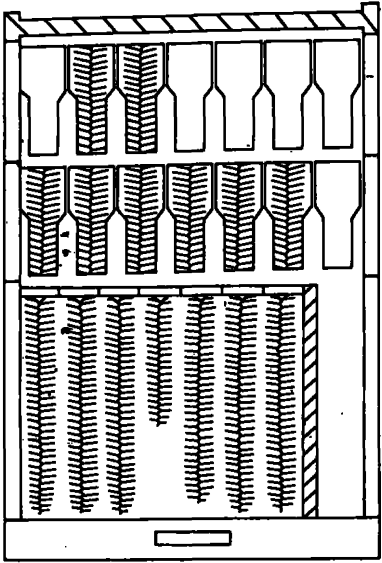

24

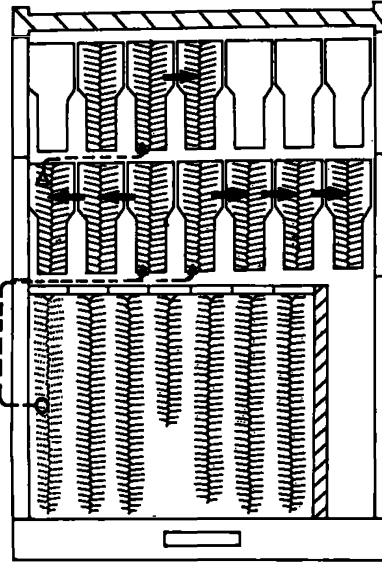

25

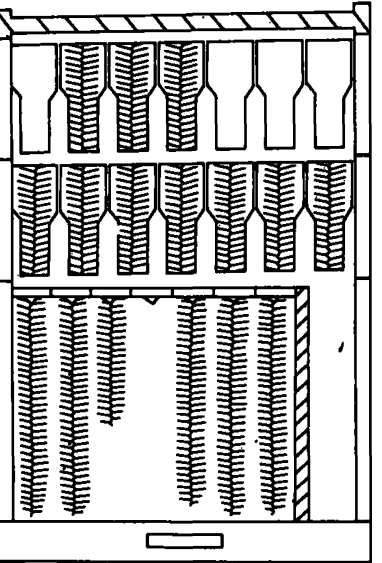

26

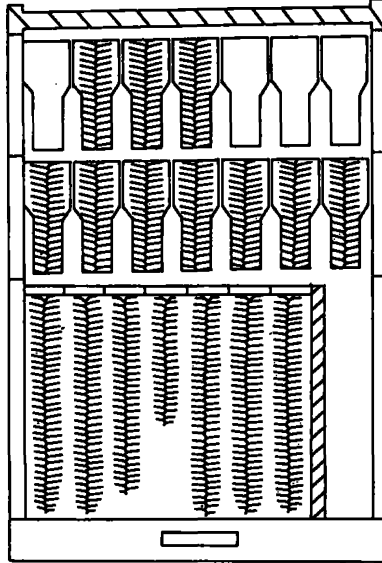

Figure 5.31: Expanding the nest to second super and completing the first super. Stages 21 to 26.

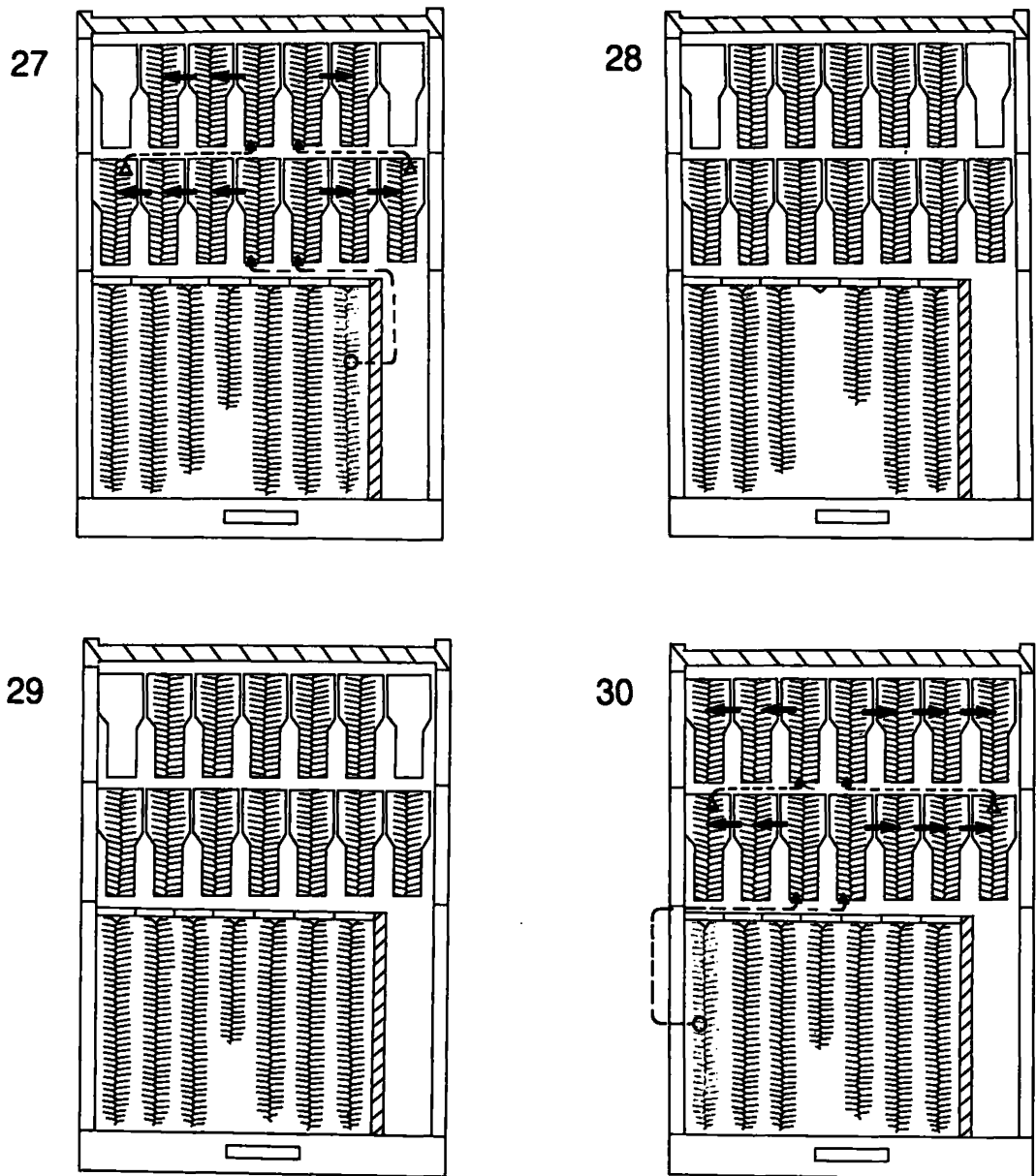

Figure 5.32: Completing the second super. Stages 27 to 30.

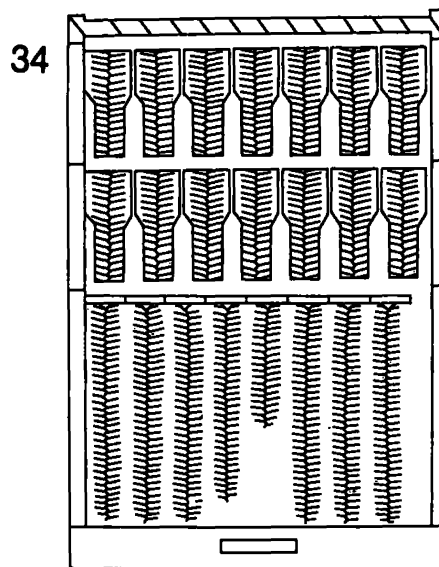
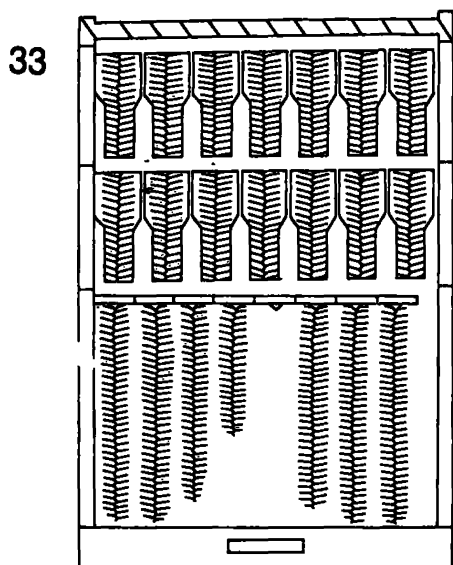
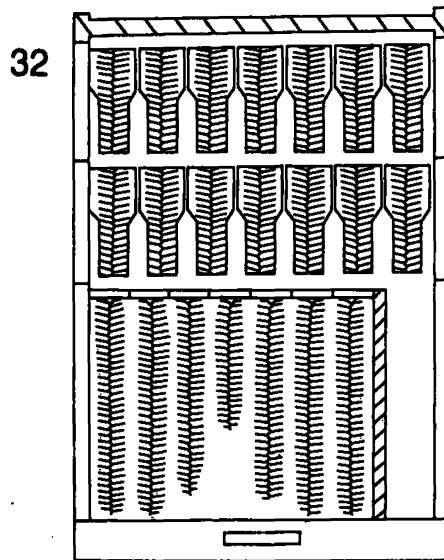
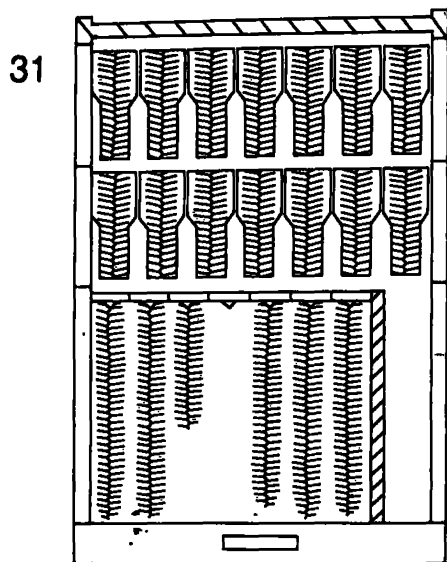

Figure 5.33: Completing the brood chamber and removal of the dummy board.
Stages 31 to 34.

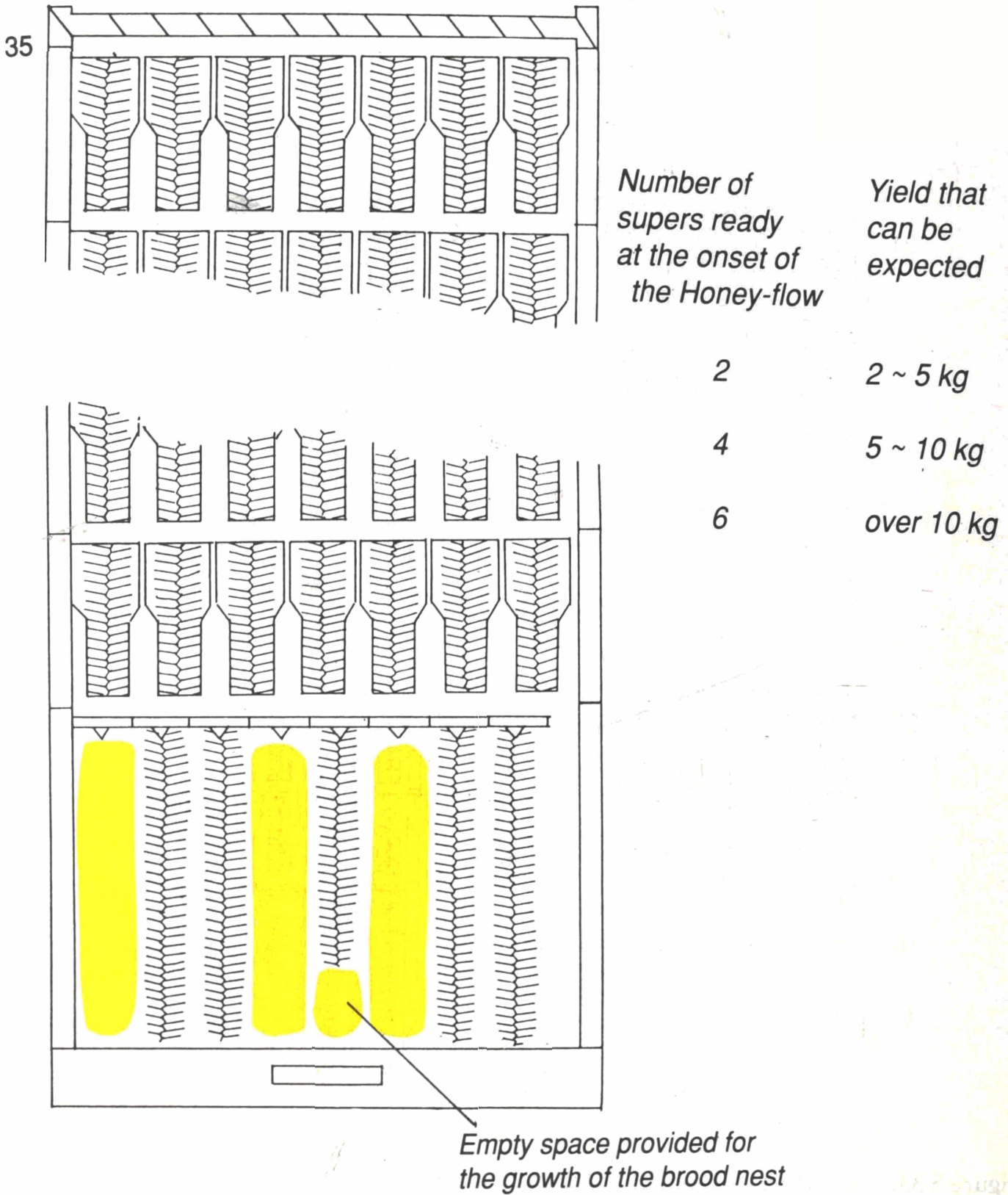

Figure 5.34: Condition of the hive prior to honey-flow and possible yields depending on the nest size. Stage 35.

As a general rule, the maximum annual supplementary feed requirement for a colony should not exceed more than 5 kg of sugar and the minimum honey yield expected should not be less than 10 kg. With these limits in mind the beekeepers should plan for the colony size. If one can not operate within these limits beekeeping may not be a viable economic proposition (see Chapter 10, Economics of Beekeeping)

If one starts with a small colony with two brood frames, the growth achieved at the initiation of the honey-flow may be up to two supers in most situations, assuming that the nest building was done during the past 8 to 10 months. But if one starts with a larger colony, for instance, one which has already gone through a honey-flow in the previous season, the number of honey supers available during the honey-flow can be much more than two supers. Figure 5.34, gives some indication of the colony sizes and probable honey yields.

5.3.3.9. Uniting Two Colonies to Increase Colony Population (and Honey Yield)

The number of colonies maintained and the strength of individual colonies are two important issues that a beekeeper has to consider just before the honey-flow period. All colonies with a bee population less than two supers should not be considered as production colonies. But such should be used to strengthen others or could be united with similar ones to make larger and stronger colonies. It is much better to have a few or even one strong colony with more than two supers full of bees with combs than several small ones (with less than two supers full of bees). Therefore it is important to unite small colonies to get larger ones for better honey production.

Uniting colonies can be quite simple if done properly. First, the queen of the colony which is to be united to another should be removed from the colony. Whether the queen is removed alone (in which case the queen will be destroyed) or with a small division with one or two brood combs, is a decision that has to be made by the beekeeper. If the beekeeper decides to remove the queen with a part of the colony, the procedure adopted will be the same as for the removal of the old queen in requeening discussed in Section 6.3.

The queen-less part can be united with the queen-right colony using the paper method. Here a newspaper perforated with a pin with holes that are about 2 cm distance apart is sprinkled with sugar syrup on either side and laid on top of the queen-right colony. Before placing the paper, the queen-right colony is smoked. Then the queen-less colony is placed on top of the queen-right colony in such a way that the sugar syrup sprinkled paper is in between as shown in Figure 5.35. The queen-less part should also be smoked through the ventilation holes. The hive is closed from top and kept overnight.

Bees will begin to chew through the paper (Figure 5.36) and by the time they meet the colony odours have mixed enough to unite them in harmony and they would not fight with each other. The beekeeper should now transfer the good brood combs to the queen-right colony at the bottom to make a single brood box and old brood combs in both should be fixed to the honey frames to restore and strengthen the supers.

5.3.3.10. Judging the Growth or the Decline of the Colony Population

A good indicator of the growth or decline of the colony population is the amount of bees covering the inside (under-side) of the inner cover (see Figures 5.15 & 5.16) and the outside of the dummy board. While opening the nest it is a good idea to check the under-side of the inner cover. For this purpose one can simply lift the inner cover from one side and look at the inside of it. If clusters or more than one layer of bees are found on the inner cover, it indicates congestion. This means that the colony has been growing and more comb space has to be provided in the supers. Similarly in colonies where the brood box still consists of the dummy board, there can be many bees on the outer surface (the side that is not against the brood nest) of the dummy board. Both these situations indicate the necessity to give more nest space. In the case of supers it has to be more combs and in the case of brood box an empty space to build more combs.

Similarly if there are combs not covered by bees it indicates the decline of the population. In which case one has to reduce the nest space to the required size and/or commence feeding to build up the population again.

As a rule the optimum nest size is determined by the comb area that can be covered by a single layer of bees. Bees would not cluster in other parts of the nest except at the bottom of the brood nest which they do to assist in the incubation of brood which it contains. But clusters of bees hanging outside the entrance in the night indicates a high congestion inside the hive, which should be corrected without delay (see Chapter 6).

5.3.4. Population Management During the Honey-flow Period

In many situations in Sri Lanka the duration of a honey-flow is between 4 to 6 weeks. During this short period, one has to find profit for all the efforts that went into preparing colonies for the honey-flow during the past 10 months or more.

The most important event influencing the size of the colony population is the swarming that takes place at the on set or during the honey-flow period. This subject is discussed separately in Chapter 6.

Another important aspect is that, there should be enough space in the brood chamber for the combs to grow further. During the honey-flow, most of the empty cells get filled up with nectar, leaving almost no room for the queen to lay eggs. This can happen even in well managed colonies where all the supers are provided with combs to receive the in-coming nectar. When this happens the only space that is available for the queen to lay eggs will be the cells that are just appearing at the ends (edges) of the growing combs.

The provision of space for growth in the brood chamber is especially important for colonies that were divided for swarm control at the commencement of the honey-flow. For the queen to

lay eggs there should be enough space and this space comes chiefly from new combs that are just being built-up rather than from the ones which existed earlier. Therefore it is important to realise and provide spaces for new comb build-up in the brood box during the onset of the honey-flow. In Figure 5.34 (stage 35) this aspect is high lighted.

5.3.5. Population Management During the Dearth Period

The period after the honey-flow is usually a lean period without much food supply from the environment. Therefore the colony should be given enough stores to go through this period. Preparation for this lean period should be done at the time of the last extraction of honey. In general, a super full of honey should be given for the bees to feed on so that they can survive this period.

Often one can see a progressive reduction in the colony population which is most evident in the bee coverage of the supers. This shrinkage of population is inevitable and it can be allowed to proceed for about 5 months after the honey-flow. Often during this period the combs in the top-most supers become devoid of bees and Wax Moth larvae will inhabit them.

When the beekeeper is absolutely certain about the cessation of the honey flow he can remove the supers progressively even before there are signs of population decrease. Though this creates congestion in the nest it will not trigger the swarming impulse as there is no honey-flow. In fact this is one of the effective ways of preventing the Wax Moth invasion of empty honey combs which will be very valuable for the next honey flow-season.

As the population begins to shrink one can remove the combs in supers starting from the top most. Along with that the crown board should be moved downwards, giving the appropriate nest-size. The shrinkage of the nest should be allowed only up to six brood combs. Keeping a maximum limit for the reduction is important as during the next 5 months the same colony (usually a daughter colony) has to be rebuilt for the honey-flow. Even the daughter colonies or the divisions made at the onset of the honey-flow (see Section 6.3) with 2 or 3 brood combs (i.e. 2~3 litres nest size) will grow in size to about 2 supers nest size (i.e. 16 litres) during the honey-flow season which lasts for about 8 weeks. In situations where the shrinkage of the colony has gone beyond the maximum permissible level, the shrinkage has to be arrested by feeding with sugar syrup, which, of course will increase the cost of production. Therefore the cost of off-season feeding is one factor to be considered in selecting apiary sites (discussed before in section 2.3).

It is quite possible that a colony going through the dearth period and facing a severe shortage of nectar gets into an absconding phase. Therefore one should be cautious about this. The management of colonies under the absconding impulse is discussed in Chapter 7.

5.4. Preservation and Storage of Empty Honey Combs for the Next Season

When colony population begins to shrink it is important to preserve the empty super (honey) combs as they would be needed for the next honey season. Beekeepers should not wait until the super combs are empty and devoid of bees but should gradually remove them as the colony starts to shrink. Therefore the honey combs should be removed while there are still some bees covering them.

The greatest danger facing empty combs are the Wax Moth larvae. The Wax Moth larvae will invade combs even when it is still covered by some bees. Often the first signs of invasion are difficult to see and at the beginning the silken webs can not be seen. Therefore it is quite safe to assume that all honey combs that were partially covered with bees may have been invaded by Wax Moth larvae. The only way to detect the "invisible" initial infestation which is somewhat unnoticeable is to hold the suspected combs against a strong light source such as an electric bulb or the sun. Then one is able to see the movements of tiny larvae in the middle or the midrib region of the comb.

The top most empty honey combs partially covered by bees should be removed without delay and preserved immediately. The empty honey combs should be preserved in batches by keeping them in air tight polythene bags. An effective preservation procedure is as follows:

1 Polythene Bag Method

Keep about 5-10 empty honey combs in a polythene bag. Twist the open end (mouth) of the bag well to make it air tight. The twisted end is bent and tight fastened with one or two rubber bands. Make sure the bag will not bloat up due to excess of air during all these operations. These bags with preserved combs could be stored in a card board box with a few moth balls (Naphthalene Balls) which should be kept in a cool and a dry place in the house (Figure 5.37) Naphthalene balls should never come in touch with wax combs. If wax combs absorb the Naphthalene smell they would become useless for bees again. No chemical substance should come in contact with combs as it can contaminate honey. Naphthalene balls are used only to discourage any insects such as cockroaches etc. who may come to lodge in the storage box and may damage the comb containing polythene bags.

When it is the time to give these preserved combs back to colonies, they should be taken out and arranged in a super box just the way how it is kept in the hive. Then the complete super could be given to a hive in need.

This method is useful only when one is absolutely sure that no wax moth larvae has invaded the combs, unless the larvae will grow inside the bags. One of the effective ways to get rid of the un-noticeable wax moth larvae from combs is to keep the combs in a freezer for a few hours (at -6°C the normal freezer temperature for 8 hours will kill all stages of wax moth)

before they are being packed in polythene bags. However, the use of refrigerators are still not common in Sri Lanka, therefore it may not be very practical.

The second method mentioned below is another effective way to detect and destroy the wax moth larvae but requires specially made storage devices which occupy more space.

2 - Ventilation Method

In this method the habit of wax moth larvae not invading a single comb suspended in free air is utilized. Therefore, in this method the combs are arranged in such a manner as not to allow them to touch each other and provide free air movement all round each and every single comb. Such a comb arrangement made in special racks constructed for this purpose is shown in Figure 5.38 which provides a 30mm air space between combs. The comb racks should be kept in a place with very good air movement or ventilation and such is shown in Figure 5.38. A few days after packing the combs in ventilation racks the combs should be re-checked by holding against a strong source of light for the possible Wax Moth attacks taken place earlier but undetected at the time of packing. If Wax Moths are found they should be removed with the use of a splinter or a forceps if available. Or the Wax Moth attacked combs could be given to a bee hive with a good active colony of bees to clean the Wax Moth larvae (see Section 7.5.). Combs that are free from Wax Moth larvae could be stored in polythene bags.

One of the problems in this method is that the bulky nature of the comb-packed racks. Though the comb rack adds to the cost of honey production it is worth having one as empty combs too are very important in producing good amounts of honey.

It is better to use the polythene bag method if one has access to a refrigerator and the ventilation method if one does not.

5.5. Summary of the Management Practices

Table 5.1: Generalized Management Practices in Two Honey-Flow Conditions Under Rubber Growing Areas (Western and Sabaragamuwa Provinces) and under Eucalyptus Areas (Bandarawela region, Badulla District).

Stage or Management Phase	Rubber Honey-Flow	Eucalyptus Honey-Flow	Important Management Practices
Growth Period Increasing Comb area and the Colony population (Expanding Nest)	September October November December	March April May June	<ul style="list-style-type: none"> - Supplementary feeding to enhance growth. - Building up the honey-supers
Pre-Honey-Flow	January	July	<ul style="list-style-type: none"> - Swarm management - Uniting Colonies
Honey-Flow	February March	August September	<ul style="list-style-type: none"> - Swarm management (at the early part) - Honey extraction
Post-Honey-Flow	April	October	<ul style="list-style-type: none"> - Honey extraction if the season was long or late
Dearth Period Decreasing the Comb area and the Colony population (Shrinking Nest)	May June July August September	November December January February March	<ul style="list-style-type: none"> - Removal of empty combs in the supers for preservation and storage - Prevention of Absconding by supplementary feeding



Figure 5.35: Uniting colonies 1: The colony #34 is queen-less (on top) and about to be joined with Colony #89 which is queen-right (bottom) using the paper method. The sugar syrup sprinkled news paper is placed on top of the queen-right colony.



Figure 5.36: Uniting colonies 2: A day after bees have perforated through the paper and have joined together to form a large colony.



Figure 5.37: Storage of empty super (honey) combs and brood combs. They could be kept in air tight polythene bags and stored in a cool dry place.



Figure 5.38: Arrangement of empty brood and super combs in the storage rack. Note that none of the combs touch each other and the combs are arranged in such a manner as to give good air circulation around them.

6. Management of Swarming and Production of New Colonies

6.1. Swarming

Swarming or the process of natural reproduction will take place with the onset of the rapid growth phase at the beginning of a honey-flow. Uncontrolled swarming leads to a drastic reduction of the colony population which will greatly hinder the successful exploitation of a honey-flow.

But swarming is an inevitable natural consequence of growth in a healthy colony of bees at the onset of a honey-flow. Therefore one should not try to prevent swarming by either the destruction of drone combs, whose appearance is one of the early warnings given by a colony in its preparation for reproduction. Nor should one destroy the queen-cells which appear later. It is more profitable to harness this natural process and benefit from it by allowing the process to take place under the control of the beekeeper.

It is often thought that a young queen replaced well ahead (one or two months before) of the honey-flow will not try to swarm during the honey-flow. But all experienced beekeepers know that whatever the age of the queen, the bees always tend to swarm at the onset or at the middle of the honey-flow. This is something the beekeeper should keep in mind, and be ready for.

The major causes of swarming are congestion or increase in the density of bees and the lack of space for the queen to lay eggs due to filling up of all combs with in-coming nectar in a hive. Often such congestion occurs while approaching the honey-flow and swarming takes place at the onset of the honey-flow. Therefore it is important to make provision, such as is discussed in Section 5.3.3. to relieve the congestion by increasing the nest size and by the systematic transfer of old brood combs to the supers as the colony grows. Figure 6.1 illustrates the bee population density concept in swarming. The main remedy to minimize swarming is to reduce the bee population density as the colony grows. The virtual impossibility of reducing the bee population density is the main problem in all other types of hives (pots, logs, etc) where the nest can not be manipulated effectively. Even a movable comb hive will produce the same results unless the combs are manipulated in such a way as to increase the comb area as the colony grows. Whether the nest is built in a movable comb hive, a traditional pot or in a natural cavity, the outcome is the same (Figure 6.2) if conditions lead to congestion or the increase the density of the bees. Therefore, the movable comb hive is no better than a pot hive or a natural cavity, unless the beekeeper is capable of manoeuvring it as and when necessary (Figure 6.3).

One of the major disadvantages of swarming is the reduction of the bee population in a colony at the onset or at the middle of the honey-flow, if swarming is not properly managed. The bee population is directly related to the amount of foragers who collect nectar to make honey. Then swarming can cause substantial reduction in honey yields.



Figure 6.2: Overflow of bees beyond the size of the nest built in the natural cavity of a tree trunk.



Figure 6.3: Even though this nest of honeybees occupy a movable comb hive; this expensive hive, serves no purpose. The bees have built combs in the super frames under conditions of high congestion. The combs are built across the frames making them immovable. The other obvious disadvantage will be the excessive swarming. Combs should have been managed as discussed in Section 5.3.3.

However one can not prevent swarming as this is the natural process of colony reproduction. Swarming should take place when the conditions are ready for it. Therefore, swarming should be managed in such a way as to benefit from it rather than to loose by it.

The biological conditions that are necessary to trigger the natural impulse for colony reproduction or swarming in honeybees take place as follows. Both the daily egg laying rate of the queen and the brood rearing ability of the house bees increase with the onset of the honey-flow due to the abundance of food. The increased quantities of bees that are produced during this period will aggravate the congestion within the nest on the one hand and increase the population of nurse-bees (see Table 1.3) on the other. These nurse-bees with very active Royal Jelly producing glands (hypopharyngeal glands, see Figure 1.19) are waiting to produce more and more queen larvae to dispose of their product. With these chain of events it will trigger the urge to produce a new queen for the natural reproductive process or swarming.

In general a well managed colony at the time of swarming should have a minimum of 7 combs in the brood box and a minimum of 2 supers- complete with combs where all three compartments are entirely covered by bees. It is advantageous to have more supers than this minimum amount and the beekeepers should try to manage the colonies in such a way as to achieve this.

6.2. Predicting the Preparation for Swarming

The appearance of a drone brood in newly-built combs (Figure 6.4) could easily be seen at the times of routine colony inspection to determine the growth rate of combs for comb transfer to the supers. Once the appearance of drone brood is observed, the beekeeper should plan for the next set of events which is very important for successful beekeeping.

Appearance of drone brood will take place even when excessive feeding is done as much as at the beginning of a honey flow. If the feeding rate is maintained at the same level, the emergence of drones are followed by the construction of queen-cells and swarming will eventually take place. Therefore, it appears that an abundance of nectar is the prime cause of triggering the swarming impulse.

It is not always necessary to examine the combs for drone brood to predict the swarming. If the beekeeper keeps a watch on the hive entrance during the drone flight period of the day, between 15:00hrs to 17:00hrs he will be able to see **flying mature drones**, if any have appeared in the colony at all. Drones do not fly at all times of the day, haphazardly, but only during an exact period in the late afternoon, which is called the **mating flight period**. Existence of flying mature drones is a sure indicator of the possibility of swarming within the next few weeks.

It may be added that the appearance of drones will depend on the continuity of the food supply, artificial or natural. If there is a fall in the food supply the drone production will not be followed by the appearance of queen-cells, which would otherwise be the usual pattern.

As said before, when the nectar supply to the colony is plentiful the swarming impulse takes place, which is followed by the construction of drone cells and this is followed by the construction of queen-cells. The queen-cells are usually constructed at the bottom margins of the brood combs. Therefore, if the beekeeper has followed the natural sequence of events leading to swarming and is convinced that swarming is about to take place, he will need to examine colonies to determine the existence of queen-cells. For this purpose he will have to check each brood comb individually, as the queen-cells may be at the bottom margins of any of them.

All well managed colonies which have arrived at a honey-flow should have fairly large numbers of bees, something in excess of 25,000 workers. Such colonies are rather difficult to examine due to the large population and possibility of inevitably getting a few stings during the examination. If the beekeepers are using top-bars in the brood box instead of frames, he could examine the condition of the brood box with ease, by using the simple device called the "**mirror box**". The mirror box is a contraption which is open from the top and sides and fitted with a slanted mirror at the bottom (see Figures 6.5 & 6.6). If a hive separated from the floor board is kept on the mirror box, the development phases of the brood combs that are built on top-bars could easily be observed (see Figure 6.7). The mirror box is especially useful if one keeps a fairly large number of colonies where it would involve much time and trouble to examine all the brood boxes.

The same principle can be applied with a household mirror for which two persons are necessary. One would have to lift the hive separated from the floor board and the other would have to hold the mirror underneath the brood box. Then the brood nest should be smoked from underneath to clear the combs of bees in order to do the comb examination. But this is a rather cumbersome operation. It would be more convenient to use a mirror box where a single person can do the same work, more efficiently.

The mirror box offers the following advantages:

- 1 The time taken for the examination of the condition of the brood box can be very short, and perhaps shorter than the time spent on examining one comb.
- 2 There is no need for the manipulation of combs.
- 3 The disturbance caused to the brood box is minimal or practically nil.
- 4 The possibility of bees getting agitated, aggressive, causing them to sting minimized to the least degree.
- 5 Especially with regard to the developing stages of queen-cells, a more exact comparison could be done as all of them become visible at the same time (Figure 6.7).



Figure 6.4: Appearance of drone brood in a newly built comb is a timely indication of preparation for swarming. The drone brood in the lower portion is quite distinct from the worker brood above. As the drone brood matures a distinct hole appears in the middle of the capping as seen in the middle of the brood comb.

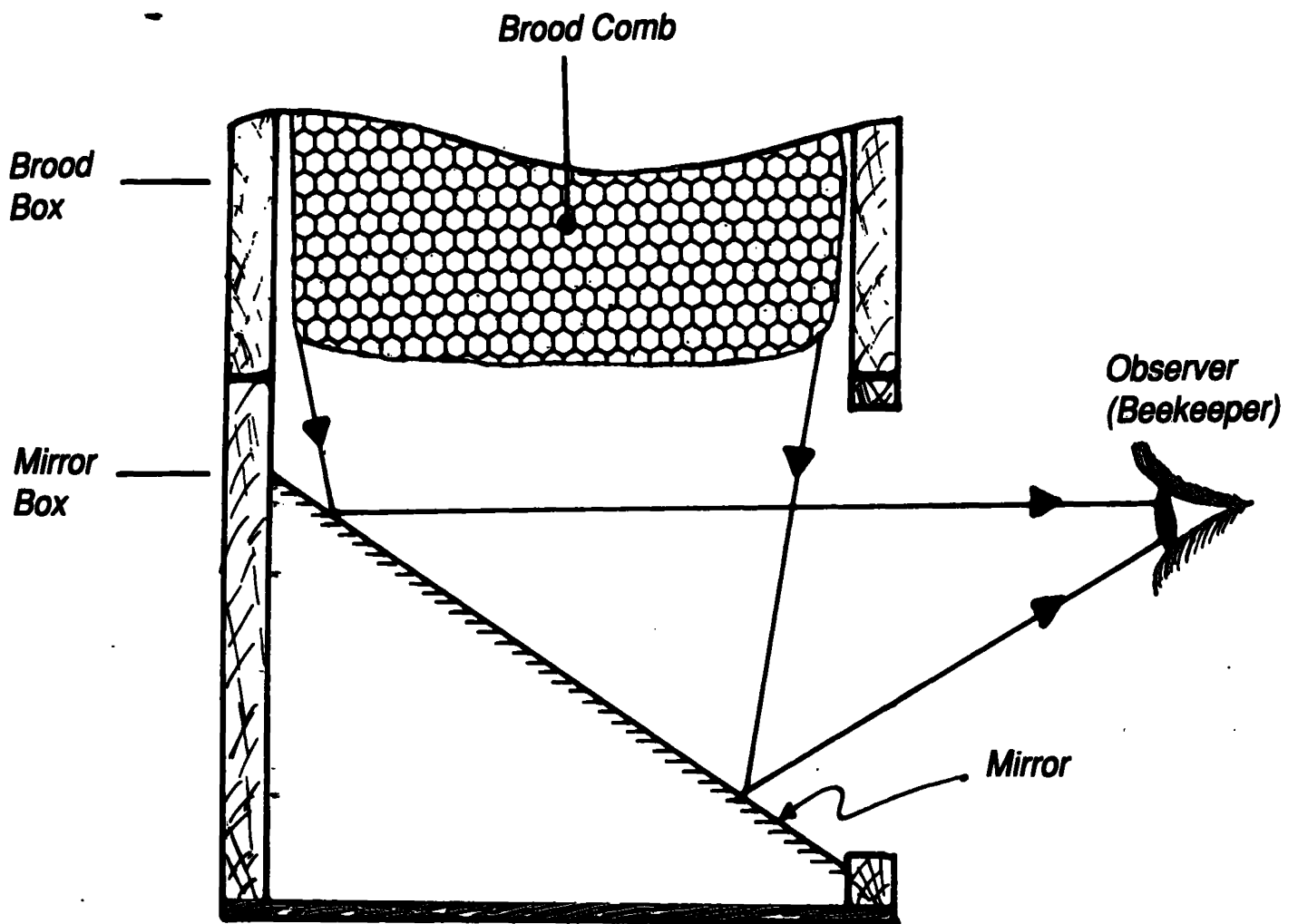

Figure 6.5: Principle of mirror box which can be very useful in the management of colonies.



Figure 6.6: Using a mirror box to examine the brood box. Sending a few puffs of smoke will clear the bottom ends of combs from bees and then one can easily observe them through the mirror.



Figure 6.7: Details of the condition of the brood combs (or nest) as seen through the mirror. Note the difference between worker brood and drone brood the latter protruding out of the comb. Queen cups and cells are also seen through the mirror box and various stages of maturity are easy to observe.

6.3. Management of Swarming and Production of New Colonies

With the appearance of the queen-cells, some very crucial management steps and manipulations procedures have to be performed. And these are as follows:

- 1** The beekeeper waits until at least one queen-cell is matured. Maturity of the queen-cell is determined by the thinning of the conical tip of the cell which makes it darker. If the beekeeper does not want to take a chance the colony division can take place at any time after sealing of queen-cells. But it is important to remember that the larvae inside an immature queen-cell is more prone to injury than a pupa inside a mature queen-cell. Figure 6.8 shows immature queen-cells where the tip of the queen-cells are not thinned out and the pupa inside is immature.
- 2** In contrast to Figure 6.8, the Figure 6.9 shows a mature queen-cell with a thinned-out tip. When one such queen-cell is visible the colonies have to be divided immediately. Otherwise the old queen will leave the hive with the prime or the first swarm in a matter of a few days or a few hours. Figures 6.10 and 6.11 show the emergence of a young queen.
- 3** Now it is imperative to open up the hive and to examine the brood box thoroughly to find the old (existing) queen. This is perhaps the only time one should look deliberately to find the queen. Often one is able to find her in the brood box but it is not unusual to find that she has migrated to the supers if the colony has advanced to the stage of swarming.
- 4** Once she has been detected, the brood nest is divided as queen-right and queen-less divisions, depending on which part gets the queen. The queen gets between 25% to 40% of the brood nest or two to four brood combs (Figures 6.12). Further all the supers too are given to the division with the queen. It is important to remove all the queen-cells and queen-cups from this queen-right division. Queen-right division with the reduced brood nest and all the honey supers are the intended honey producing colony of the current season. The most complete brood combs with the best of the queen-cells should be taken for the queen-less division.
- 5** In the queen-less division, the best queen-cell (Figure 6.9) is left while all the other cells of the same age or a little younger are removed or destroyed. There is no strict criterion for judging the best queen-cell. Normally the most mature cell without external deformations is considered best. What is important is to remove all the cells of comparable age, except the one that will remain. The removal of extra queen cells are most important in divisions with large populations. The idea behind this is that only one queen will emerge to lead the queenless colony and if more than a single queen emerges there may be more divisions of the colony breaking up resulting in a drastic reduction in the colony strength.

6 It is also important to retain one or two immature (or younger) queen-cells (normally referred to as sealed stage) or cups (normally referred to as unsealed initial stage). An immature queen-cell or a queen-cup is allowed to remain as a precautionary measure against the colony being left queen-less in the event of an accident occurring to the only mature queen-cell left. Once the queen from the mature queen-cell emerges and is mated, the bees usually destroys the other queen-cells which might emerge later as queens and lead the colony.

If the population in the new queen's colony is more than a population of bees that can cover three completely grown brood combs, there is a tendency for her to swarm. This often happens when there are other queen cells such as the ones that were kept behind as a precautionary measure. Therefore the queen-less division can be further divided into three-brood-comb or two-brood-comb divisions (The amount of empty hives at the beekeeper's disposal will determine the number of divisions to be made). This is also an effective way of increasing the number of colonies which could be sold later. Usually there are about 800 to 1,000 worker bees on a fully grown brood comb (over 80% grown, see Figures 5.25 & 5.26) that has entirely been covered by them. Therefore even if there are several queen cells in a division with about 2500 - 3000 workers, the bees will not swarm but instead they themselves will control further swarming (a self-regulating-dividing method). Therefore, in such an instance it is not necessary to control (or remove) extra queen-cells.

7 If one resorts to the self-regulating-dividing method, the queen-less divisions and the queen-right honey producing colony can be spread out in the apiary close to each other as shown in Figures 6.13 & 6.14. What is important in understanding this method is **not** to keep any colony at the original location but to keep all the colonies around it at a radius of about 1-2 metres from this original site. Then most of the field-bees returning to the original location will hover around this site for a short period but will join the queen-right colony nearby in a while. By this method all colonies will have desirable populations of bees in the end.

One of the ideas behind this colony-dividing method is to give all the field bees to the queen-right colony as many as possible nurse-bees to the queen-less divisions.

Removal of nurse-bees from the queen right colony will suppress the further queen-cell building or swarming impulse where they tend to build queen-cells, such colonies may not collect nectar and produce honey effectively. Therefore removal of the swarming impulse from the honey production colony is very important.

Then, the question will be, how can we transfer the nurse-bees? It is rather simple. Remove a brood comb full of bees from the queen-right colony. Make sure the queen is not in it. If the queen is there allow her to walk in to another comb. One can get her on to a super comb frame and leave this frame in the brood box temporarily. Take this brood comb out of the hive, send a few small puffs of smoke.

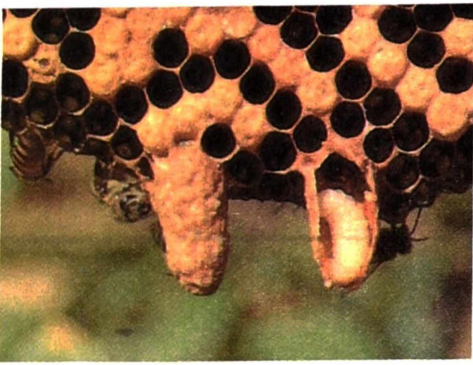

Figure 6.8: These queen-cells are not matured enough. Notice the un-thinned tip of the queen-cell (left) and the soft immature pupae inside the opened cell (right).

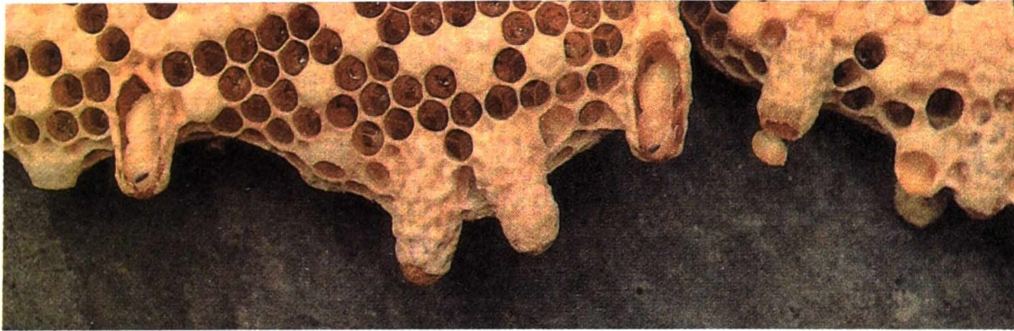

Figure 6.9: A matured queen-cell indicated by the thinned-out tip which becomes relatively dark (brownish) compared to the upper parts (3rd queen-cell from left). The pupa too are maturing as indicated by their dark eyes (2nd & 5th from left). The body colour of the pupa on the right is about to turn darker. The open queen-cells at the two ends (1st & 7th from left) are called queen cups. The young queen from the most mature queen-cell (6th from left) has already emerged and the cut-open cap is still intact.

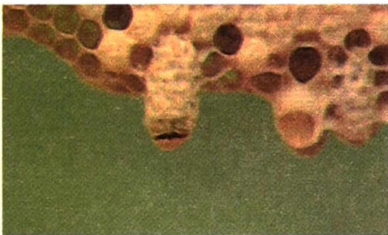

Figure 6.10: A young queen is about to emerge from a mature queen-cell. She has started cutting through the cap of her cell.

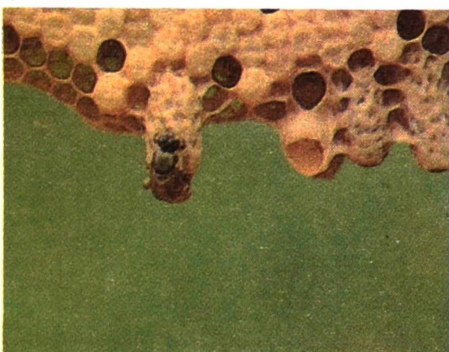

Figure 6.11: The new young queen coming out of her cell.



Figure 6.12: Colony dividing. Here the existing queen is given two combs of brood from the original brood nest (in hive #76) and she will be given all the honey supers in the background to form the honey producing colony. The queen-less division now in hive #34 can be further divided in to 2 or 3 divisions provided each will get a good queen cell to raise new queens.



Figure 6.13: Self-regulating colony dividing method 1: Large honey producing colony (#033) and three small divisions set around the original site. The original site is marked with a yellow ribbon in the middle of the hives.



Figure 6.14: Self-regulating colony dividing method 2: Large honey producing colony (#113) and two small divisions set around the original site. The original site is marked with a yellow ribbon in the middle of the hives.



Figure 6.15: Brushing the nurse-bees off the brood comb to add them to a queen-less division.

Some bees will fly away. The bees that remain are the non-flying house-bees of which the majority are the nurse-bees. By using a "Bee Brush" these nurse-bees could easily be brushed into a queen-less division as shown in Figure 6.15. A bee

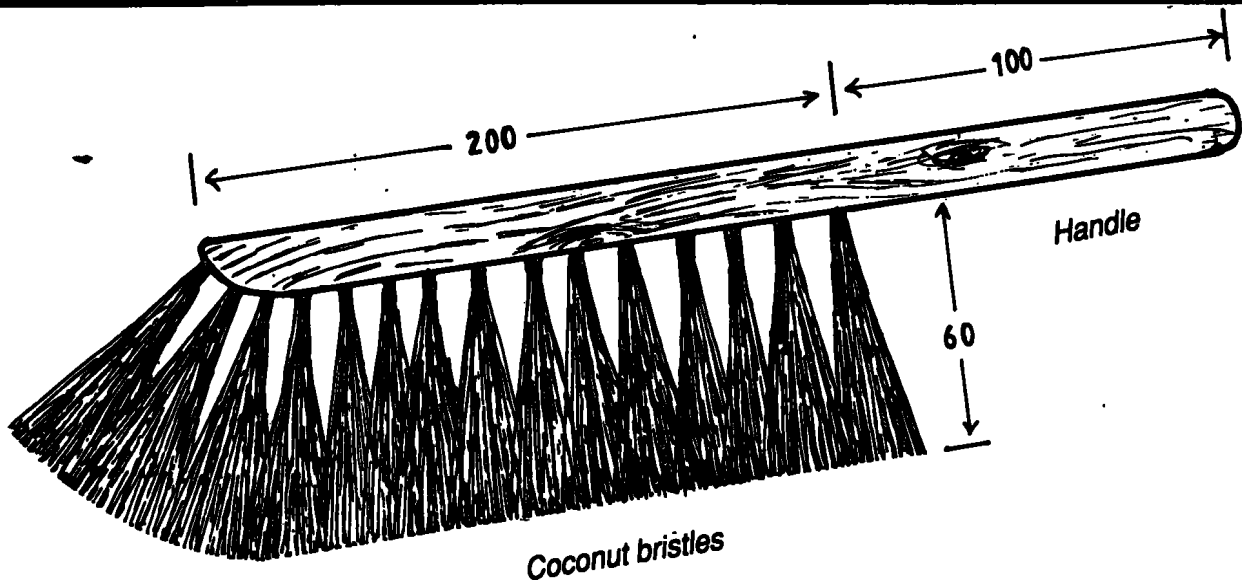

Figure 6.16: A Bee Brush (Not to scale, all dimensions in millimetres).

brush such as shown in Figure 6.16 could easily be got made by a Coconut coir (fibre) broom and brush maker. A large bird's feather also could be used as a Bee Brush if necessary. The Bee Brush can also serve as a very useful device in removing bees from honey combs during honey extraction (see Chapter 9).

The summary of the colony layout in self-regulating-dividing method employed when a colony gets the swarming impulse is shown in Figure 6.17.

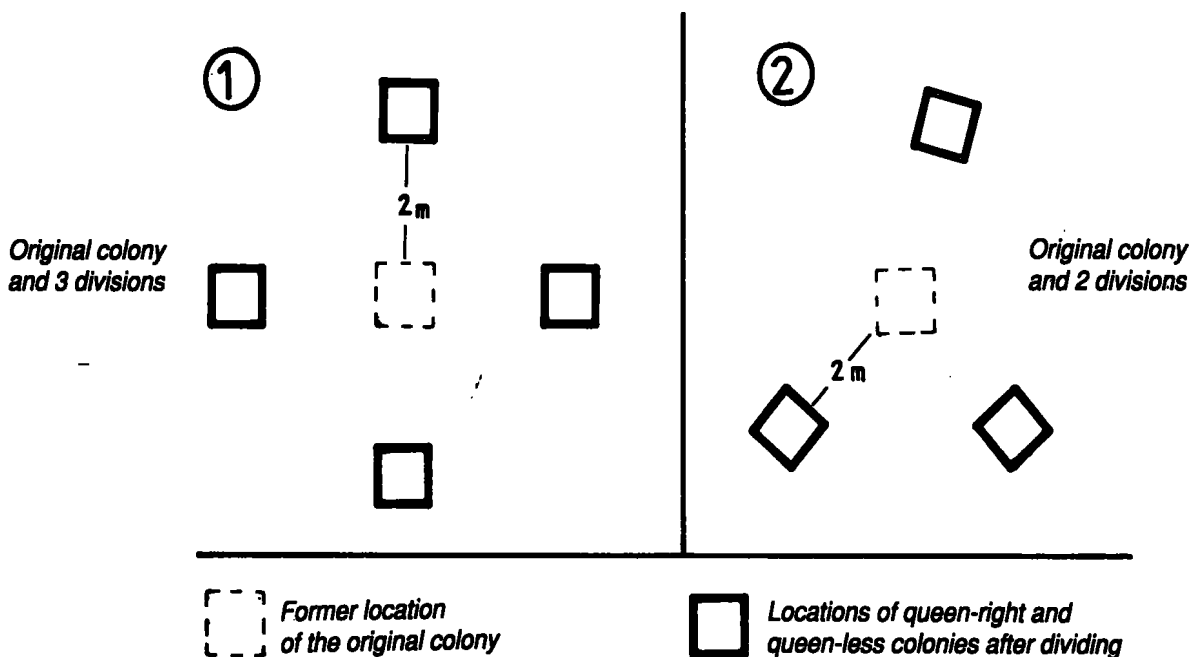

Figure 6.17: The layout of colonies in the apiary after dividing. All colonies are kept at a distance of 1-2 meters from the original location.

If the beekeeper resorts to the artificial control of queen-cells at the time of removal of excess queen-cells, he can utilize them more profitably by giving these to other queen-less colony divisions, if he has several colonies in the apiary (Figure 6.18). This is especially useful if the original colony possessed superior features such as fast growth, large colony size, higher honey yield, etc. This will enable the beekeeper to up grade his stock gradually.

Any queen-less colony will accept a queen-cell given from outside. Therefore a queen-cell can be transferred easily to another queen-less colony. If other colonies in the apiary are also showing signs of preparation for swarming, they should be considered as ripe stage for dividing. Dividing could be done at any time of the year, but our purpose is to harness the natural preparation of the bees for swarming at the onset of a honey-flow and benefit from it rather than lose. It is also important to remember that despite the queen being young the bees will usually make preparation to swarm at the onset of the honey-flow.

Supplying mature queen-cells to other colonies in preparation for swarming could be done in the following way. A mature queen-cell could be introduced to the queenless part in about 15 minutes after dividing. A mature queen-cell from the donor colony should be carefully removed with the part of the comb attached to it (Figures 6.19 & 6.20). In the recipient colony, two combs right in the middle of the brood box should be pushed to either side to make a space to introduce the queen-cell held between thumb and first finger (Figure 6.21). After having inserted the queen-cell at the level of the existing brood area in the comb, care should be taken to push the combs back so that the queen-cell which will be held between the combs by the attached piece of comb above it. Combs on either sides of the queen-cell should not be pushed too close to the queen-cell, in order to avoid the combs exerting pressure on the queen-cell. The combs should be pushed to a level that they will hold the queen-cell in such a way that it will not slide down. Once the queen-cell is positioned properly the bees would soon attach it to the adjoining combs. One should be careful in handling the queen-cell from the time of its removal from the donor colony to the time of its transplantation in the recipient colony since hasty jerks, pressing, etc. can result in injury or death of the tender pupa inside.

The acceptance of the queen-cell by the recipient colony could be checked the next day, if one is in doubt. For this purpose, one should make a space on one side by removing or moving a comb immediately next to the two combs where the queen-cell is held. Puff a light smoke just enough to move the bees away from top bars and insert two fingers from either side in the space between top bars (Figure 6.22). This will make one comb to slide away from the other and the transplanted queen-cell will detach from one comb but attach itself to the other (Figure 6.23). This is a very convenient way to examine the queen-cell and if it has been accepted one could easily see the bees attending to it. If bees seem to attend to it, leave it alone. If the bees have refused to accept it, they would have torn it apart by now and this can be



Figure 6.18: A comb with mature queen-cells. Out of these three queen-cells, the single one on left is mature enough.



Figure 6.19: One mature queen-cell is about to be cut out from the comb.



Figure 6.20: The queen-cell is removed with a part of the comb attached to it. One has to be very careful not to injure the queen-cell.



Figure 6.21: The queen-cell inserted between two brood combs in a queen-less colony that was divided about 30 minutes before.

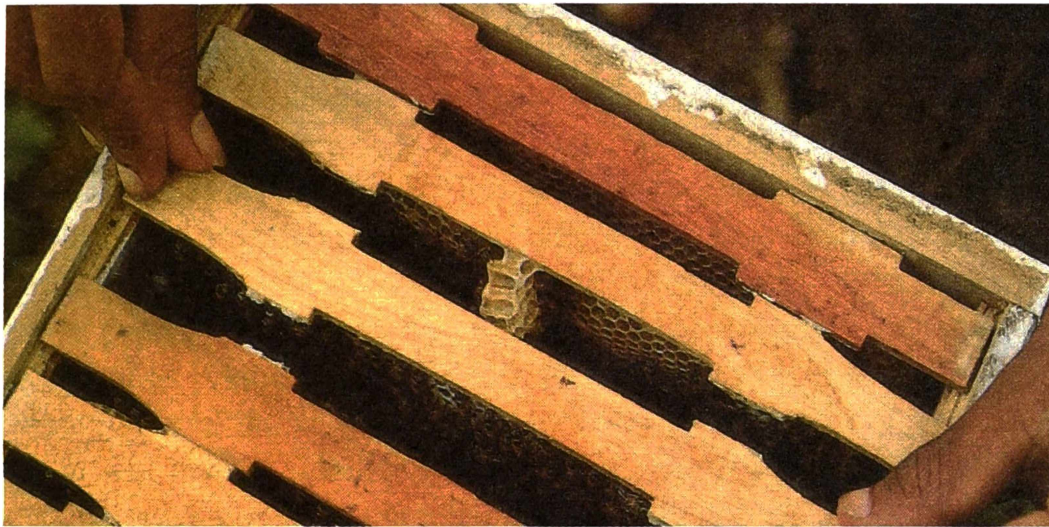

Figure 6.22: The bees have attached the given queen-cell to the comb and an adjoining top bar is moved away to inspect the queen-cell.



Figure 6.23: The bees have firmly attached the given queen-cell to combs. Here many bees have been removed to get a better view but usually many bees would cover a queen-cell to incubate it.

easily observed. Bees will refuse to accept the queen-cell only if it is already damaged and some injury has occurred to the queen pupa inside. Therefore, one has to be extremely careful in the removal and transfer of a queen-cell.

9 The small queen-less colony should be carefully attended to. It should be fed only on the day after dividing (Figure 6.24). It is important to keep in mind that the small colony may be robbed of its food by the bees in the neighbourhood. As the colony is small, it can easily be overpowered by robber bees coming from other colonies in the apiary. Therefore feeding has to be done just before dark and the quantity of the feed should be just enough for the bees to consume it during the same night. For a small colony about 100 ml of sugar syrup is enough at a time. For small colonies, it is best to repeat feeding frequently rather than giving a large feed once. The use of Dummy Board is important to manage this small colony (Figure 6.24). If the queen-less small colonies are kept in the honey producing site and the dividing was done during the honey-flow it may not be necessary to feed them. The queen-less colonies that are intended to produce a new queen are also called "mating colonies".

10 One is able to see the newly emerged queen a few days after dividing. The new queen should emerge in less than a week. If not, there is something wrong with the queen cell and a new queen cell has to be supplied again. It is important to supply brood combs, especially with large areas of sealed brood for this colony that is expected to produce a new queen. Having sealed brood in this new colony is important until the new queen is mated and starts to lay on her own. Supplying brood will help to stabilize the colony and prevent absconding (see Chapter 7). Brood combs could be obtained from the mother colony or from other honey producing colonies which have very high growth levels during the honey-flow season.

Figure 6.25 summarizes and illustrates the steps involved in colony dividing. It is better to leave 3 brood combs in the queen-right colony and give spaces in between these combs for quick re-building. For the self regulation of swarming and successful new colony production the minimum size of a queen-less division should be 2 brood combs with the bees covering them (that is about 2000 bees) and the maximum 3 brood combs (about 3000 bees).

In Figures 6.26 and 6.27 the mirror box view of the brood combs and the condition of a colony during the peak honey-flow period is shown. This colony was in time divided to manage the swarming impulse at the onset of the honey-flow and therefore it does not show any tendency to swarm now, such as in the colony shown in Figure 6.7.

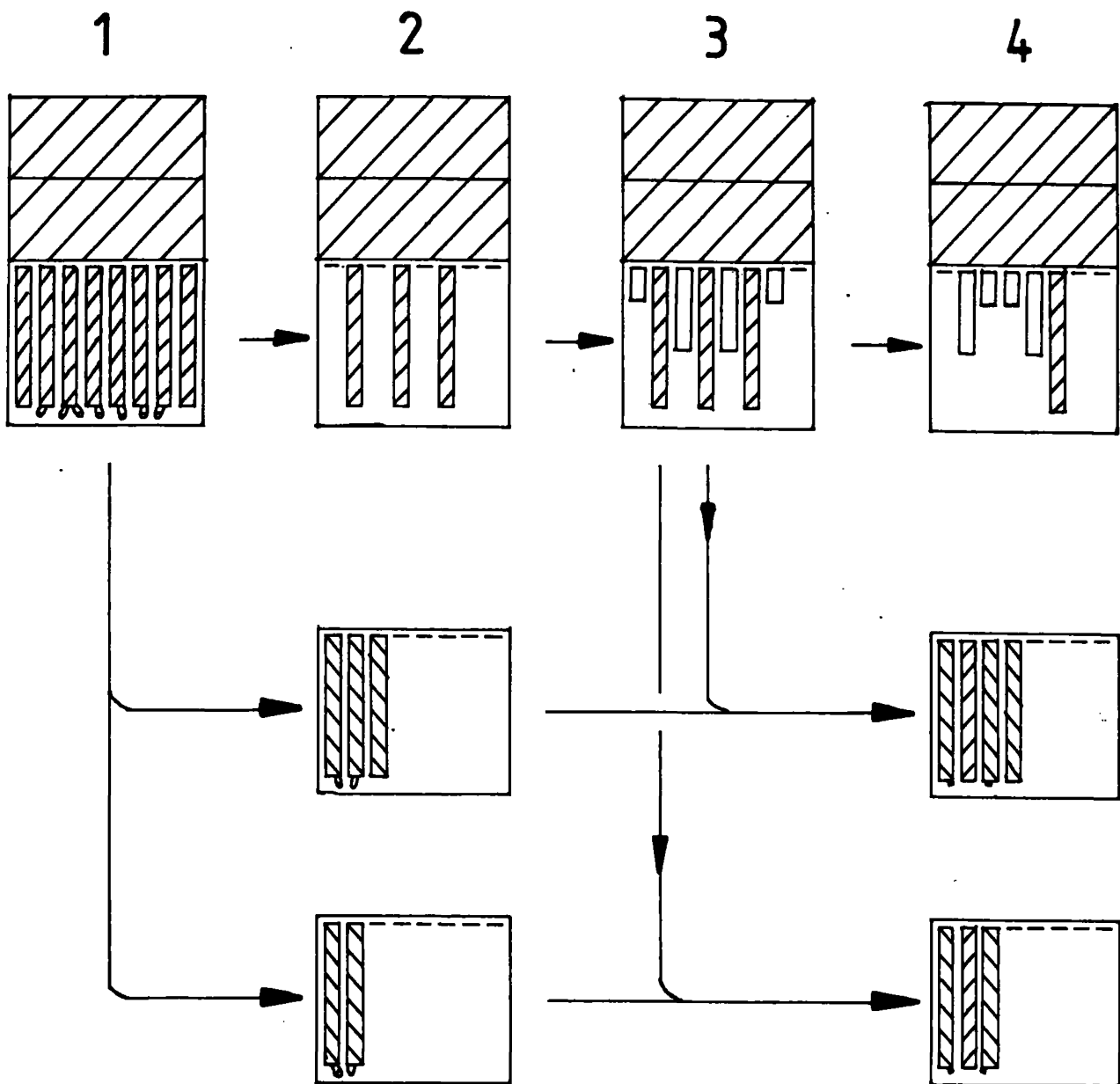

Figure 6.25: Summary of the procedure involved in colony dividing for swarm control and producing new colonies.

- Stage 1:** A colony with 8 combs in the brood box and 2 complete supers which produced queen cells at the onset of the honey-flow.
- Stage 2:** Dividing Colonies.
The existing queen is given 3 brood combs and all the supers which is going to be the honey producing colony. It is important to remove all the queen cups and queen-cells from the queen-right division.
5 brood combs with queen-cells are separated to make two queen-less divisions one with 2 and the other with 3 brood combs in them.
- Stage 3:** About 10 days later the queen right colony has produced more combs with brood.
- Stage 4:** Brood combs are supplied to the two colonies with new queens to stabilize them and to encourage the queens to initiate egg laying.



Figure 6.24: Managing a small colony such as a division with queen-cells. Note the feeder can to supply sugar syrup and the use of dummy board to protect the small nest.

6.4 Who Should Lead the Honey Production Colonies, New Queens or Old Queens ?

During the swarming season the existing queen will leave the existing nest site with part of the bee population. Then the original colony will be headed by one of the new queens that is just about to emerge from a maturing queen-cell. The queen-cell construction precedes the swarming. Therefore in the natural process of swarming the existing colony gets a new queen. However, in natural swarming the old queen takes anything between 25% to 75% of the population in the colony.

Also, it is often assumed that a new queen produced at the onset or during the honey-flow will perform better than her mother, due to her youthful vigour. Therefore often it is attempted to replace the honey producing colonies with new queens by removing the existing queens with a division of the colony. A somewhat similar procedure is practised in beekeeping with *Apis mellifera* (Western honeybee) in countries with a highly developed honey production industry called **re-queening**¹. However in a Sri Lankan context at present the following conditions favour the use of the older queen in honey producing colonies and the new queens produced by dividing during the current season are to be used in the next season (year).

- 1 Approach of honey-flow conditions will trigger higher growth rates which lead to congestion in the brood chamber. During this rapid growth phase a fresh comb will be completed to full size in about 7 to 10 days and egg laying rate may go up to about 600 per day. As a consequence of this, swarming becomes inevitable. Therefore this natural sequence can be followed to produce new queens and to keep productive foraging population intact.
- 2 During the honey-flow new queens in large colonies take a long period to initiate egg laying and can sometimes be more than 6 weeks. Moreover, quite often, the young queens in large colonies swarm out without initiating egg laying causing the remaining colony to turn “laying worker”.
- 3 Without a functional queen who is laying eggs properly the worker bees will not effectively collect nectar to produce honey. Therefore if a beekeeper depends on a colony led by a newly emerged queen the results can be disappointing if the new queen takes a long time to initiate egg laying.

Therefore the beekeepers should realize that what is important in a honey production colony is to have a functional queen irrespective of her age. Therefore a queen already engaged in egg laying can be more effective.

¹Re-queening in the context of well developed beekeeping industry with *Apis mellifera* (Western honeybee) is greatly different to what is discussed here. In those situations a beekeeper usually buys properly mated new queens often with specified weight of bees to replace the existing (old) queen in the hives, from a commercial bee-breeder at the beginning of the season. In fact a queen with a few workers are sent by post (see Table 4.1). But these techniques are still not applicable in Sri Lanka. Here, the natural process is followed to get new queens for the next season at the beginning of the present season while maintaining the population in the original colony with a last season's queen at a higher level for honey production.

However, the beekeepers has to make sure that there will be no congestion in the brood chamber (nest) for the queen to continue to lay even after dividing the colony for swarm control. It is important to have at least two spaces for fresh comb building in the brood nest at any time during the early stages of the honey-flow season (see Figure 5.34). Therefore it is advisable to remove brood combs with sealed brood to reduce the congestion that is building up and to supply these to small colonies with young queens to stabilise them (see Figure 6.25). In Figures 6.26 and 6.27 the mirror box view of the brood combs and the condition of the colony during the peak honey-flow period is shown. This colony was divided in time to suppress the swarming impulse at the onset of the honey-flow and therefore it does not show any tendency to swarm now, such as is shown in Figure 6.7.

6.5. Age of the Queen in Productive Colonies

Usually a queen has about 2 - 4 years of productive life. Therefore the older queens can be retained in the honey producing colony for a few seasons by properly timed dividing. However it is always safe to assume that after the first honey-flow season the queen may fail to lay eggs properly and therefore for the next honey-flow season the beekeeper should depend on the daughter colonies that were produced during the previous season.

In the event that there were colonies that performed exceptionally well during the last season, such colonies should be used to up-grade the stock by making more daughter colonies of them in the next season and by supplying their queen-cells to queen-less divisions of the other colonies.

6.6. Laying Workers: a problem in new colony production

In some instances, such as a young queen swarming away without laying eggs and the failure of the remaining colony to produce a new queen successfully will lead to a queen-less condition. When the bees have failed to make a queen larva, then conditions lead to the development of ovaries of some of the workers (see Section 1.4.2.1). Presence of a queen larva too can suppress the development of ovaries in workers. Workers who develop ovaries tend to take over the duties of a queen and then start laying eggs. Egg-laying could easily be recognized as these eggs are laid in large numbers in each cell (Figure 6.28). These eggs being unfertilised will give rise to drones and such colonies are sometimes called drone-laying colonies. These colonies will eventually die out as no workers have been produced. If such a condition occurs under normal beekeeping circumstances very little can be done to correct the situation and it is advantageous and profitable to join up such colonies with another queen-right colony as described in Section 5.3.3.9. If there is the possibility of giving a queen to the laying worker colony the queen should be introduced by the queen cage method described in Section 7.4.2.

One of the external indications of a colony turning laying worker is that the bees gather outside the hive body and often above the entrance. This behaviour may look somewhat similar to the over-flow of bees in pre-swarming congestion, where most of the bees cluster below the



Figure 6.26: Condition of a colony during the honey-flow period. The colony is transferred on to the mirror box to view the brood combs. The brood nest is complete with all 8 combs and the three supers full of bees will reward the beekeeper with a good harvest of honey. Same colony (#46) during harvest time is shown in Figures 9.2 & 9.4.



Figure 6.27: Condition of the brood nest of a honey producing colony during the honey-flow period. Due to timely swarm management at the onset of the honey-flow now the colony does not show any tendency towards swarming compared with Figure 6.7.



Figure 6.28: Comb with multiple eggs per cell due to some workers beginning to lay eggs. Workers develop their ovaries due to lack of queen-substance. (see Section 1.4.2.1 and also Figure 1.10)

level of the entrance. One of the distinct characters of the bees gathering outside the nest due to "laying worker problem" is that they deposit wax and sometimes build small combs on the clustering surface.

6.7. Queen Laying in Honey Supers: another problem that can take place during swarming season

If the transferring of mature brood combs to supers has taken place till the onset of the honey-flow there is a possibility for the queen to move to the supers for laying eggs. Then, the only way one could correct this situation is by placing such supers below the brood box till the queen starts to lay properly in the brood combs.

On the other hand if the brood nest in the queen-right colony is drastically reduced the re-building in the brood nest can become slower which makes the queen to move up. The queen coming to super to lay eggs during the active breeding season is long recognized in the Western honeybee (*A. mellifera*) and therefore the queen excluder was invented (see Table 4.1 p.79) to prevent this. However, the use of queen excluder is still not warranted in a Sri Lankan context yet, as this defect can be easily corrected with effective management.

Therefore, simple procedures such as timely (well ahead of the honey-flow season) transferring of mature brood combs to super frames and not reducing the brood nest of the queen-right or honey production colony beyond 3 brood combs and giving in-between spaces for quick re-build (see Figure 6.25) can help to overcome these problems.

6.8. Collection of Swarms and Natural Colonies

6.8.1. Collection of Swarms

A swarm which has settled within easy reach on a branch of a low grown tree is easy to collect. It can be easily taken by holding an empty hive (brood box or any other receptacle) under it and shaking the branch, causing the cluster of bees to fall in to the waiting receptacle (Figure 6.29). If a hive was used, once the swarm has fallen in, close the top with the crown board or the inner cover immediately. The queen guard should have been put on before the shaking was done. Often the bees will settle down peacefully to occupy the hive or may try to fly away again. If they try to fly away, because the queen guard is on the queen can not escape and the bees would come back. A few hours after the swarm has settled down in the hive, it is desirable to give them a feed in an inverted feeder.

If the branch on which the swarm has settled down cannot be shaken in, it is best to hold the empty hive complete with top-bars or frames on to the cluster carefully and slide the inner cover so that the swarm will get inside the hive. This has to be done very carefully and slowly, or the colony will fly away.

Before collection, a swarm can be stabilised by spraying or sprinkling some water. Wet bees are not so eager to fly away but tend to cluster. Sometimes some sugar is added to this sprinkling water to make it sweet so that the bees would start licking each other. Adding too much sugar may be undesirable as it causes the bees to be too sticky.

Hungry swarms are very difficult to collect and they keep absconding. Thus sprinkling a swarm with dilute sugar water and allowing the bees to feed on it for sometime will help to stabilize the hungry bees before collecting the swarm. Non-starving swarmings will settle in a hive with ease.

To catch swarms which are settled high up, it is best to use a basket (a kind of a scraping receptacle, keeping the bottom to a side) made out by bending the large leaf base of **Arecanut** or **Betel-nut palm** (*Areca catechu*: Palmae, the leaf base receptacle is called *kolapath gotuwa*) fixed to a long pole (Figure 6.30). To get such a swarm inside the "kolapath gotuwa", one has to be very slow. The "kolapath gotuwa" has to be held at one end of the swarm and moved very slowly through the swarm so as to get it inside. Often it is a good idea to apply some thick sugar syrup on the inner side of the "kolapath gotuwa" so that bees will start licking it and unintentionally enter the "kolapath gotuwa". Some times this process might take hours and a lot of patience is demanded. Once the swarm of bees have entered the "kolapath gotuwa" (Figure 6.30) it could be brought down and shaken in to a hive.

It is a good start to give a comb with good brood and stores to the newly hived swarm, if possible.

It is much easier to provide a nesting place and invite a swarm. In fact, many villagers do this. A clay pot with about 12 litres capacity could be placed in a crotch of a tree and during the swarming season, very often a nest-site-seeking swarm will occupy this. Once it is established it could be transferred into a movable comb hive or be continued as a pot hive. Just by placing an empty pot one can not expect a colony of bees to occupy it within a few weeks. It may some times take about an year or even more. It is just a matter of trying ones luck and in many non-urban areas swarms of bees are not too uncommon.

Similarly, if one happens to see or hear a swarm flying across the garden it is possible to stop it by banging metal. It is known that flying swarms could be stopped by metallic gongs or vibrations. The sound produced by hitting the mamoty blade with hammer or any metal object is effective enough to stop a swarm. Once it is done, the flying swarms tend to stop and settle down on a branch of a tree. Such a swarm can be collected as mentioned previously or a clay pot could be placed close to the swarm for the swarm to enter it, if one is unable to find a proper hive. Provision of nest sites such as empty pots, placed in the crotch of a tree in the home-garden is a practice that should be encouraged among all honeybee enthusiasts and other nature-lovers.

6.8.2. Collection of Natural Colonies

The most difficult thing in collecting natural colonies is to expose the nest by opening the access to it. One might have to cut through a trunk of a large tree, dig up a termite mound, remove big rocks, break a wall etc, etc. Where ever the nest site may be, what is important is not to disturb the nest in the process of finding access to it. Too much vibration and pounding will make the bees leave the combs and get to some other corner in the nesting cavity.

Having gained access to the nest, and assuming that the nest was not disturbed or disrupted, one should remove all combs one by one starting from one side. Here the use of smoke is essential. While comb removal takes place they should be fastened to the top-bars or frames as described in Section 4.8 (comb breakage and repair). Once all the combs are removed the hive with combs tied to top-bars should be held at the cluster of bees and if the bees are not unduly agitated, they may enter the hive to occupy the combs. If the cluster formation is in a place where the hive cannot be taken, it is best to take scoops of bees with the hand and put them in the hive. In this process, if the queen was located she could be caged and the cage could be inserted between two combs (see Section 7.4.2 and Figure 7.4). Then the cluster could be smoked to disperse the bees and the flying bees will come to the hive to settle. It is important to remember to do the comb transfer and tying as soon as possible in order to prevent chilling of combs. Bees will refuse to accept combs with dead brood in them and if this happens, the task of getting bees will be very difficult.

In certain circumstances it is much better to leave natural colonies and swarms alone if they are in difficult places to collect. It would be more profitable and convenient to purchase a colony of bees from a beekeeper.



Figure 6.29 A swarm is being hived by keeping the brood-box to the swarm.



Figure 6.30: A swarm that settled high up on a tree being taken inside the "Kolapath Gotuwa" to bring it down.

7. Supplementary Feeding for Prevention of Absconding and Pest Incidence

7.1. Absconding

Absconding or the desertion of nest site (or Hive) is the most difficult management problem of *Apis cerana* in Sri Lanka and several reasons are given for this behaviour such as shortage of nectar, genetical factors, frequent and or excessive disturbance and the existence of pests such as Wax Moths, Hornets, Ants, etc. It is clear from experiments carried out for several years that the shortage of nectar seems the most important factor responsible in causing absconding. Colonies could be made to abscond by excessive disturbance of the brood nest through artificial means, even when nectar is not in short supply.

The habit of absconding and the habit of remaining in the nest site has a distinct connection with the habit of brood-rearing in *A. cerana* and this connection can easily be recognized. A colony that would remain in the existing nest site would show a high propensity for brood rearing while a colony that has the absconding impulse shows a high antipathy for brood rearing. This tendency of propensity or antipathy for brood rearing can easily be recognized externally by the relative abundance or dearth of pollen carriers entering the nest (Figure 7.1). A quantitative estimate developed from the relative frequency of pollen carriers entering a hive per incoming bee and per time unit could be used in predicting absconding and preventing it¹.

7.2. Pollen Incoming Rate

The daily pollen collection of the foragers show a distinct pattern. The pollen collection does not take place throughout the day at the same rate. Instead, in many situations in Sri Lanka, over 90% of the daily pollen income is received during morning hours between 07:00 hours to 12:00 hours. Of these 5 hours, the most intense pollen collection period is confined to only about 3 hours, usually between 08:00 hours to 11:00 hours when more than 80% of the daily pollen income is received. Figure 7.2 shows the pollen income pattern in a colony with high propensity to rear brood, as observed throughout a day during the dearth period. Therefore the eagerness (or the indifference) to collect pollen should be evaluated during the time period where most of the pollen foragers are likely to collect pollen to identify the colonies that show a low tendency to collect pollen.

¹Punchihewa; RWK; Koeniger, N & Howpage, D (1990) Absconding behaviour of *Apis cerana* in Sri Lanka, pp 106-107. In Veeresh, GK; Mallik, B & Viraktamath, CA (Eds), *Social Insects and the Environment*, xxxi + 765 pp. 11th IUSI, Bangalore, India, ISBN 81-204-0532-3, Oxford & IBH Publishing Co. Ltd, New Delhi, India.

Punchihewa, RWK (1992) Absconding behaviour, pests and new management methods for *Apis cerana* in Sri Lanka, p 87. *Internat. Confer. Asian honeybees and bee mites*. ISBN 974-579-820-7, Chulalongkorn University, Bangkok, Thailand & IBRA, Cardiff, UK.

The relative pollen income of a colony or the empirical estimate of **Colony Performance Index (CPI)** is evaluated during the peak pollen-flow period of the day, when external conditions (such as rain) are not restrictive of foraging activity and the colony remains undisturbed for making observations at the entrance to the nest.

$$\text{CPI} = \text{Amount of Pollen Supplied per Bee} \times \text{Amount of Pollen Supplies per Unit Time} \times 100$$

or

$$\text{CPI} = \frac{\text{Number of Pollen Foragers entering the hive}}{\text{Total Number of Bees entering the hive}} \times \frac{\text{Number of Pollen Foragers entering the hive}}{\text{Observation Period in Seconds}}$$

or

$$\text{CPI} = \frac{(\text{Number of Pollen Foragers entering the hive})^2}{\text{Total Number of bees entering the time} \times \text{observation period in seconds}} \times 100$$

or in other words

$$\text{CPI} = \text{Bee intensity of Pollen Supply} \times \text{Time intensity of Pollen Supply} \times 100$$

In general, during the peak pollen in-flow period of the day, on an average a minimum of 12 bees should return to the hive for a one minute period and of these 12, at least 3 should be pollen-carrying.

Then at this point in time the CPI will be,

$$\text{CPI} = \frac{3}{12} \times \frac{3}{60} \times 100 = 1.25$$

When the in-coming of pollen has been reduced to this rate, it should be considered as an ultimate warning (CPI = 1.25) prior to absconding. Beekeepers should try to maintain the colonies at a higher CPI level by feeding sugar syrup prior to this CPI level. The danger of waiting until the colony reaches a low CPI level is that, by that time, the colony may have reached the stage when the worker bees have ceased their cleansing behaviour and defence behaviour. As a result of which Wax Moth larvae would have been allowed to trespass and lodge in the brood nest and/or Ants may have been allowed to intrude.

The estimation of CPI or the relative pollen-incoming rate during the period of highest intensity of pollen-gathering activity (Figure 7.2) will tell the beekeepers whether the colonies are getting ready to abscond. In the example given in Figure 7.2 the average CPI level evaluated throughout the high intensity pollen-gathering period was 29.60 ± 13.75 indicating a high propensity for brood rearing. What is important to know are the lower limits as discussed above. The upper limits can be anything. For instance during a honey-flow it may even go well

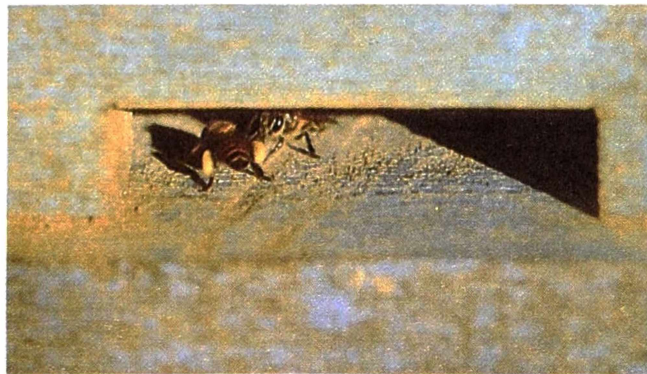

Figure 7.1: Observation of pollen foragers at the hive entrance is an easy and effective way of knowing about the conditions inside. Here a returning pollen forager inspected by a guard bee.

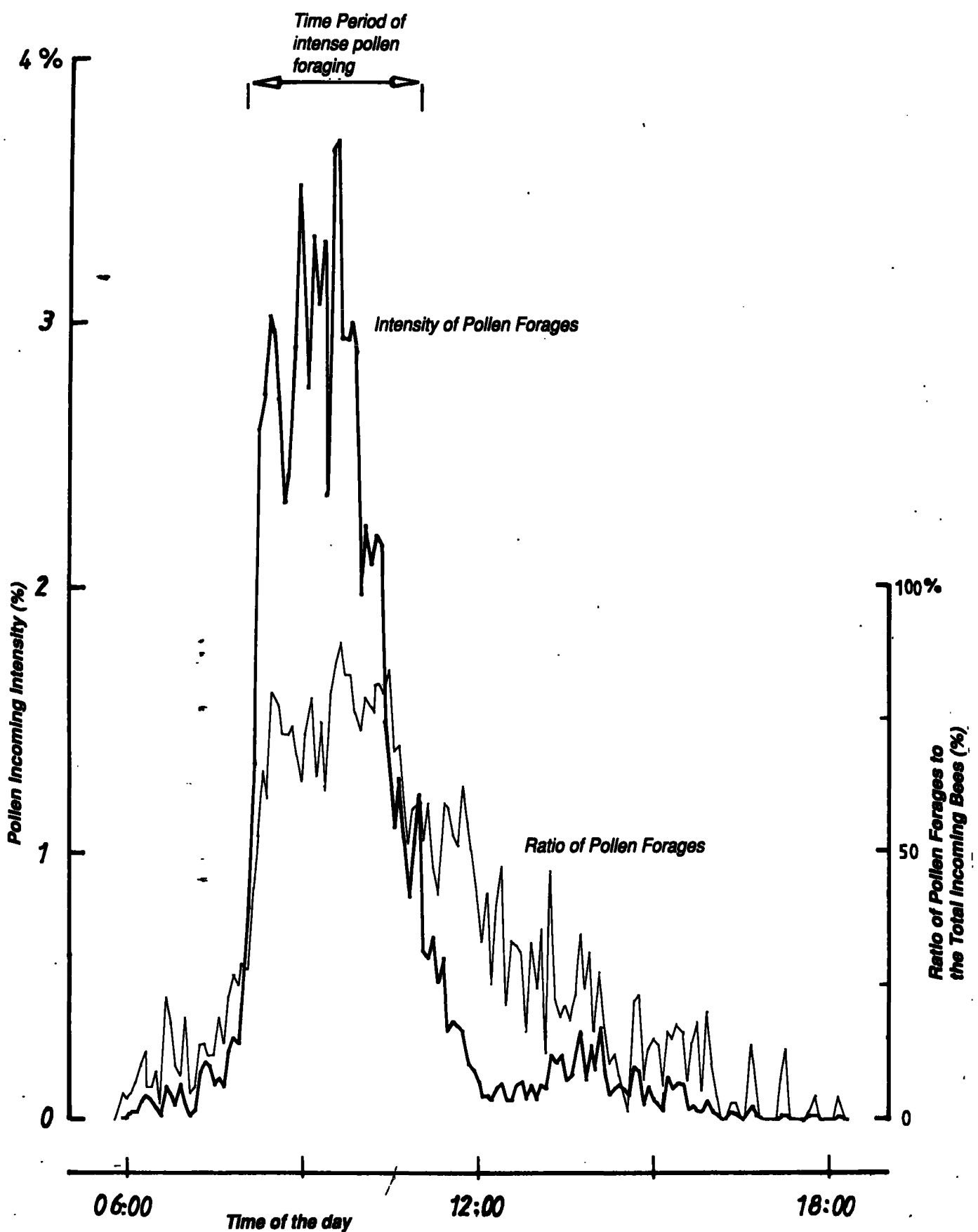
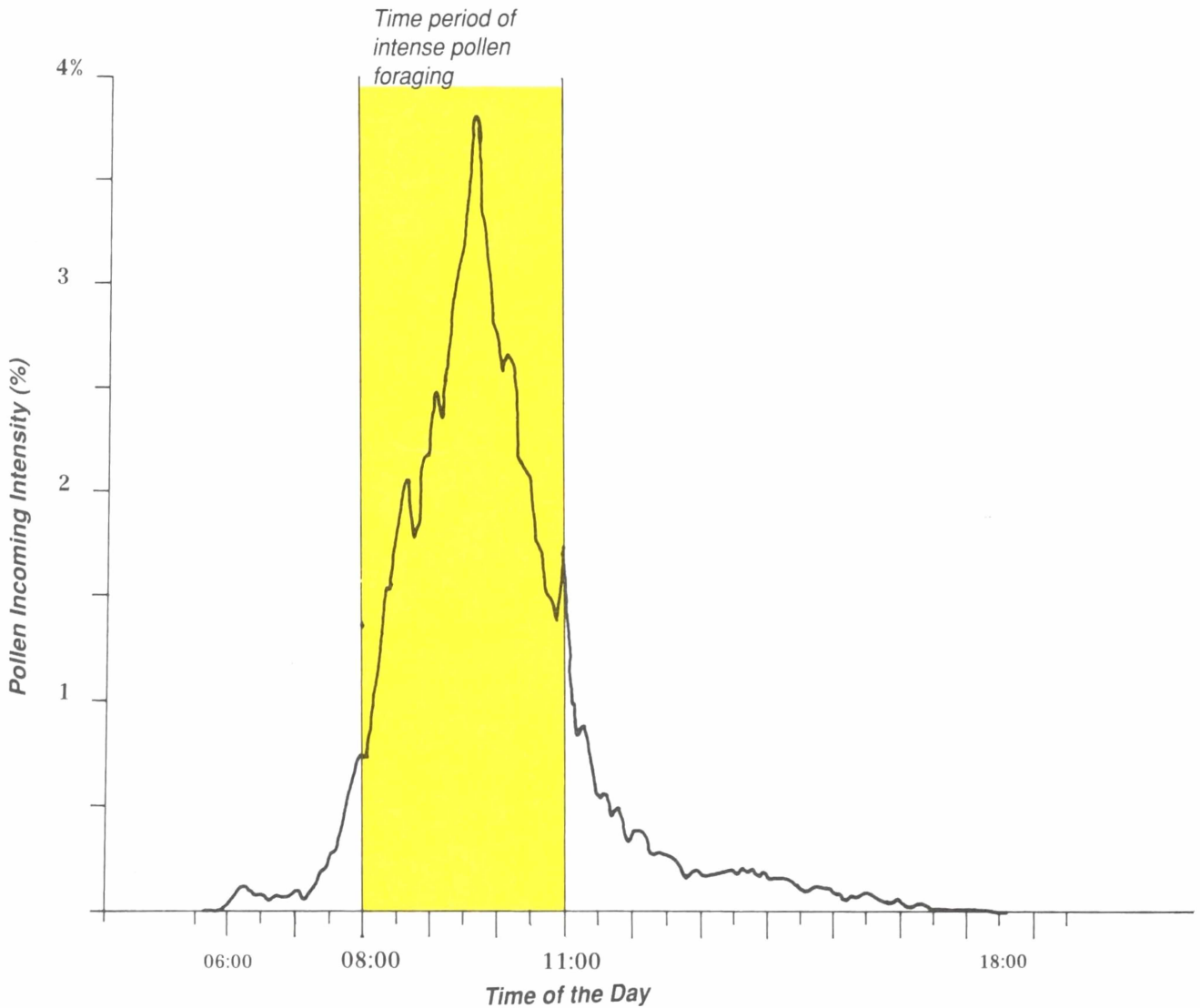

Figure 7.2: Intensity and ratio of pollen foragers returning to the hive during a whole day. Observations were taken continuously and recorded every five minutes. (1992 August 19th, Horana, Total number of bees returned to the hive 12,235 and total number of pollen carrying foragers 5,346 for this day. The observation colony had a nest volume of 20 liters with about 30,000 bees)

The General Pollen Foraging Pattern of the Day



Location: Horana , Sri Lanka (1992 May to December)

Figure 7.3: Average pollen forager intensity pattern of a colony evaluated weekly throughout a period of 8 months. 91% of the pollen foragers entered the hives between 07:00 hrs to 12:00 hrs and 80% of the pollen foragers entered the hives between 08:00 hrs to 11:00 hrs. (This graph based on nearly 100,000 observations between 1992 May to December).

above 100, and this only tells us that the bees are actively rearing brood and therefore they are actively collecting pollen. But to predict absconding what is important to know is their disinclination to rear brood.

The reliability of observing a colony of bees between 08:00 hrs to 11:00 hrs to evaluate the affinity to rear brood through the pollen incoming rate could be appraised by the curve in Figure 7.3. Here the average pollen forager intensity pattern is evaluated thorough out a period of eight months on a weekly basis when external conditions were not restrictive of foraging flights. This long term pattern also shows a close resemblance to the daily pattern in Figure 7.2 indicating dependable nature of this time period for evaluation of the affinity to rear brood; in many situations in Sri Lanka.

7.3. Preparation for Absconding

The shortage of nectar and/or excessive disturbance to the brood nest are the common causes of triggering the absconding impulse. Once a colony gets the absconding impulse, it shows a peculiar behaviour. The colony does not defend itself against intruders such as Wax Moth, Ants, etc. and ceases to rear brood in spite of the fact that the queen continues to lay. Therefore, the Wax Moth infestations of combs, broodlessness combs and presence of intruding insects such as Ants, which become apparent in colonies preparing themselves for absconding are secondary events, rather than primary causes of absconding. Hence, the management of *A. cerana* should be done in such a way that there is always a sufficient supply of nectar for continuous brood rearing activity and a minimal disturbance to the brood nest is ensured.

Before a colony absconds several stages of behavioural deviations take place inside the colony.

They are,

- 1** Reduction in brood rearing or disinclination for brood rearing.
- 2** Stoppage in cleaning behaviour.
- 3** Stoppage in defence behaviour.
- 4** Initiation of cannibalism where first the adult bees devours the young larvae, then the older larvae and later even the pupae.

Externally a progressive reduction in relative abundance of pollen-carriers entering the hive becomes evident if one makes daily observations at the hive entrance.

If the brood nest is disturbed exceedingly, the bees would perforate the capped brood and may initiate cannibalism. If Wax Moth larvae are introduced to such a colony, the bees would not exert any defence or cleaning behaviour towards them. Therefore the idea of frequent examination of colonies for the purpose of cleaning the Wax Moth from combs and floor boards may, in fact, be harmful by encouraging bees to abscond. It is best that colonies should be least disturbed during the dearth period. If the colonies are not starving but are supplied with syrup, they would do the cleaning themselves.

7.4. Prevention of Absconding

As a general rule, undisturbed colonies should not be allowed to give a CPI value below 2, during the peak pollen flow period of the day. If a colony seems to give a CPI value below 2 it should be rechecked. After confirming the low pollen-income rate, syrup-feeding should commence immediately and the colony should be watched for the elevation in the CPI value on the next day and day after. In this manner, the absconding rate could be kept at a minimum level. Therefore beekeepers can profit a lot by simply examining the hive entrance during the morning hours and this can be a reliable routine check on the condition of the colonies.

However, there can be instances where a colony shows a very low CPI (less than 1) value and this means, that the absconding impulse is firmly established there. In such an instance the colony may not respond to syrup feeding alone. Then, the only way to increase the propensity to rear brood is to give the colony a comb of brood along with sugar syrup. The brood comb so supplied should have sealed brood and stores of honey and pollen. This brood comb should be free from workers of the donor colony.

If the preparation for absconding has reached an advanced stage where the CPI value is zero or the beekeeper has no other way of finding a brood comb, the only option left is to make a "Pseudo-Absconding" of the colony to break the absconding impulse. The mechanism here is to allow the bees to fly away but to prevent the queen from going with them. This can be done in two ways, as follows.

7.4.1. The Queen Guard Method

Once the colony has failed to respond to sugar feeding, the combs should be checked. All combs now infested with Wax Moth larvae should be removed. There is no harm in removing all the combs, if they are devoid of any sealed brood. Put the queen-guard on. The colony should abscond in a few hours or if not the next day. The bees will fly away to abscond but will return to the hive because the queen can not escape. When bees return to the hive after the absconding attempt, feed them with about 500 ml of sugar syrup. They will re-establish themselves in the hive, just like a new swarm. If the old combs are not yet badly damaged by the Wax Moth, these could be given back to the colony to help in their nest building. This method works well with hives which are in good condition, where the queen cannot escape through cracks and crevices in hive parts.

IMPORTANT: There is no reason to keep the queen or entrance guard on permanently to prevent absconding. It is only a nuisance for the foragers in a healthy colony and a hindrance to cleaning-bees, drones, guard-bees, etc. The queen guard is a minor device in managing bees helpful in catching swarms, etc., and not a remedy for the problem of absconding. If the bees in a hive get the absconding impulse, they would fly away and the queen-guard will help to bring them back perhaps only once or twice. If the conditions for the bees are not improved they would repeatedly try to abscond and eventually go away even without the queen, in spite of the fact that such a colony will not survive long.

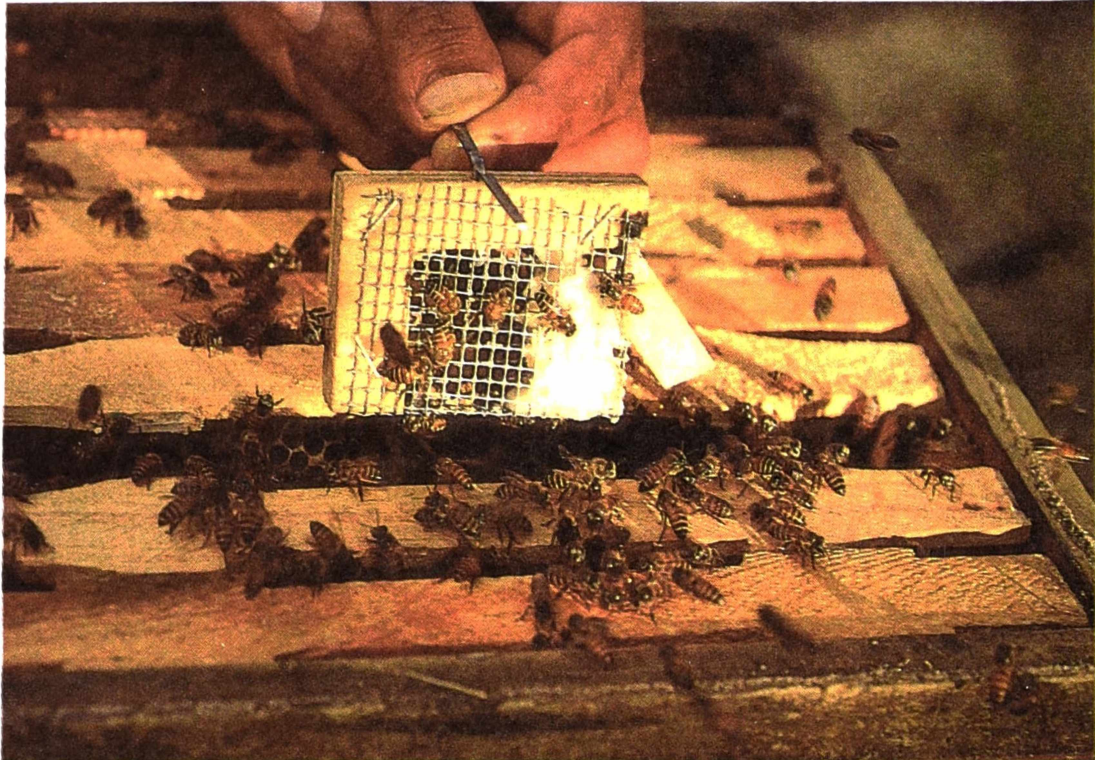

Figure 7.4: Queen cage with queen inside. The entrance plugged with candy paste before opening the door. The cage is about to be inserted between two top-bars. The wire on top now swung out helps to suspend the queen cage between two top bars.

7.4.2. The Queen Cage Method

At the time of colony cleaning, the queen should be searched and she should be caged. This is important in hives with cracks where the queen can escape with flying bees for absconding. As previously, within hours of cleaning the combs damaged by Wax Moth larvae, the bees would try to abscond but would return as the queen has not joined them. At this point one should feed them well and they will settle down like a new swarm. The queen should be released the next day. It is a good idea to plug the entrance of the queen cage with sugar paste (powdered sugar made to a paste added with a few drops of honey) before opening the cage door. The bees will eat through the sugar paste to release the queen (Figure 7.4). Immediate release of the queen may some times lead to balling her by the bees and subsequent killing.

The idea behind both methods mentioned above is to allow the bees to abscond if they want to do so. This is the best way to break their stimulus or the impulse to abscond. Once the bees get the absconding impulse strongly established, it is difficult to break it, unless they perform the ritual of absconding. Here we allow them to do it under our control.

7.5. Defence Behaviour

If combs infested with Wax Moth larvae were given to colonies with greater propensity for brood rearing and with high frequencies of pollen carriers entering, the bees would quickly shred the silken galleries and remove the Wax Moth larvae inside. Similarly, if predatory ants were lured into the nest by offering dead bees, soon the bees would kill the Ants that enter the nest and would drop them to the bottom.

Figure 7.5, shows the introduction of a Wax Moth infested comb to a colony. Non-starving colonies will instantly pull out the Wax Moth larvae even if they were to be introduced by force (Figure 7.6) while in colonies that are starving the Wax Moth larvae will trespass without any hindrance. Figure 7.7 shows the same comb in Figure 7.5 which is now completely covered with bees actively cleaning the Wax Moth larvae and their silken galleries. Figure 7.8 is the same comb after being cleaned in about an hour.

Similarly, non-starving healthy colonies exhibit effective defence against predatory Ants and hornets. The popular notion about the ability of strong colonies to defend against Wax Moths and Hornets does not mean colonies with a lot of bees, but colonies that are not hungry, irrespective of the size of the population .

Hornets can hunt bees only when the bees are stationary and are in the open. For instance a Hornet may devour a bee that forages on a flower or is strolling outside the hive. Hornets sometimes hover around hive entrances, searching prey and they would land on the hive only when the colony is weak due to starvation. Starving colonies are defenceless and fall prey to Hornets. Figures 7.9 and 7:10 illustrate the reaction to a Hornet by a non-starving colony of bees. In Figure 7.9, shows how a live Hornet tethered to a small wire is brought near the brood

nest and bees begin to react instantly. In a matter of seconds the bees make a mass attack and cluster round the hornet. The bees have a mechanism to generate heat in this bee cluster which is high enough to kill the animal inside in a few minutes. Figure 7.10 shows the heating mechanism of bees where they have raised the temperature of the cluster by 10°C above the normal brood incubating temperature, which is lethal for the hornet. The temperatures were measured by very small electronic temperature feelers (thermistors) attached to the Hornet and to brood combs. The temperatures were registered in the two electronic recorders in the background, where the one on the left records the brood incubating temperature and the one on the right registers the temperature around the Hornet. From Figure 7.11 it becomes clear that bees have not used their usual defence reaction of stinging the intruder, to kill the Hornet. Therefore, the bee cluster could be easily kept on the palm.

The inability of the Hornets to fly and hunt in closed spaces also should be used to discourage them from approaching hives. Hornets cannot fly too well through the spaces among foliage unlike in wide open spaces, but the bees can. Therefore if the hive entrance is somewhat concealed with foliage, such as shown in Figure 7.12, it will give less chance for the hornet but will give a better chance for the bees to mass attack a hornet who would try to approach the hive.

The Interaction Between Honeybee and Ants

Usually the Ants (there are more than 100 species of Ants in Sri Lanka) attack a colony of honeybees only when the bees are in a state of weakness due to starvation. A colony of bees in good condition can overcome intruding Ants. However there seems a special association between the Dimiyas or the biting large red tree ants or the Weaver ants (*Oecophylla smaragnida*: Formicidae: Hymenoptera) and the Mee Bees. Usually Dimiyas do not attack Mee Bees and the bees do not seem to possess any special adaptation to avoid them as well. The guarding Mee-Bees hover around the intruding Dimiyas to discourage them from entering the nest (see Figure 7.13). However, if any body part of the hovering bee is caught by the Dimiya the bee will be subjected to a mass attack by them. If Dimiyas intrude the nest, the Mee Bees will escape them by performing an emergency absconding process where all the adult bees abscond from the nest leaving the brood and food stores behind.

When a nest of Mee bees happen to be within the area of activity or influence of Dimiyas the bees will obviously fall a prey to them. Under certain environmental conditions Dimiyas seem to expand their area of activity or their niche. The vegetational conditions around the Mee Bee nest seem to determine the niche of the Dimiyas. When the ground area surrounding the bees nest or hive is covered with grass or other vegetation the Dimiyas are reluctant to approach and when the ground area is bare the Dimiyas are encouraged. Usually in dry season the Dimiya problem is more prevalent; also it has been observed that when other species of Ants such as Kalu Kuhumbi or small black Ants, Kadiya or the large biting black Ants, Ratu Kuhumbi or the non-biting red Ant, etc.) lodge at close vicinity to the Mee Bees nest the Dimiyas are discouraged. Usually these other species of Ants construct their nest within the space between inner cover and roof (see Figure 7.14). Therefore, the above factors could be



Figure 7.5: Cleaning behaviour 1: Introducing a Wax Moth infested comb taken from a colony that was in preparation for absconding to a non-starving colony. Note the silken webs of Wax Moth larvae covering some cells. Time 09:22:57.

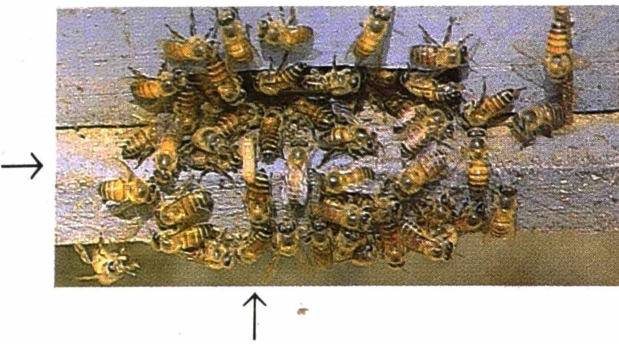

Figure 7.6: Cleaning behaviour 2: Wax Moth larvae carried away by bees. To locate the Wax Moth larvae project the arrows inside.



Figure 7.7: Cleaning behaviour 3: The bees have completely covered the Wax Moth infested comb to clean it of them. Time 10:14:24.



Figure 7.8: Cleaning behaviour 4: The view of the comb that is cleared of Wax Moth larvae and their silken galleries by the cleaning bees. The bees have taken about 58 minutes to clean the comb: Time: 10:20:17.



Figure 7.9: Defence behaviour 1: A tethered Hornet brought near the brood box and the bees start to react instantly. Time 10:52:27, brood rearing temperature 34.2°C (left indicator) and environment temperature taken next to Hornet 29.8°C (right indicator). To locate the hornet in the picture project arrows inside.



Figure 7.10: Defense behaviour 2: The hornet is entirely covered by bees and the temperature has risen to 44.0°C which is enough to kill the Hornet. Time 10:59:43.



Figure 7.11: Defense behaviour 3: The bees who clustered around the Hornet in making the high temperature bee cluster to kill it do not exhibit the stinging behaviour. However, due to the disturbance caused in taking the cluster on to the palm a small drop in temperature is evident. Temperature 41.3°C, Time 11:06:07.



Figure 7.12: Foliage in front of the hive entrance. This is a very effective way of discouraging hornets who would like to roam around hive entrances.



Figure 7.13: The conflict between the **Dimiya** (weaver ant) and the Mee Bee. The bee hovering above the Dimiya ant prevent it from invading the nest.



Figure 7.14: A type of a **Kadiya** (Ant species) which builds its nest in the space between the inner cover and the roof. There seems to be no conflict between other Ants and bees. In fact it is observed that when other species of ants lodge in the vicinity of the Mee Bees' nest, the Dimiya Ants are discouraged from coming near.

used in combination to overcome the Dimiya problem. It may also be practical to keep the hives away from the trees that bear Dimiya nests and or away from their foraging range. Application of a layer of thick petroleum oil or grease around the hive stand is another temporary solution in times of intense Dimiya attacks to discourage them from coming near the nest. The little honeybee or the **Danduwal Bee** uses a similar method to protect its nest from predatory Ants where a band of sticky resins are constantly applied on either side of the twig of the tree, where it builds its nest. This sticky protective resins layer is seen clearly in Figure 1.3 (on the upper left side) on page 6.

What is important in managing the Mee Bee is to understand its requirements and natural adaptations. Even though absconding is considered one of the major problems in beekeeping it is an important natural adaptation for its survival. A Mee Bee who is adapted to forage on a small foraging area is extremely prone to starvation due to shortage of food in places of scanty vegetation. Most of the human habitations are lacking in proper vegetation to support Mee Bees. Thus the only option left for the Mee Bees reared in such situations is to migrate to another environment with food availability when starvation begins. Or else the beekeeper has to provide the bees with supplementary feeding. Therefore, it becomes important for the beekeeper to determine the time of supplementary feeding and the simple technique of evaluating the Colony Performance Index (CPI) will help the beekeeper in doing so. By using the CPI the beekeeper as well as the bees can avoid the hassle in elaborate colony examination to clean Wax Moth infestations etc. Bees will do a much better job in cleaning their nest than the beekeeper as long as they are not starving.

Therefore, the management of *Apis cerana* would be easy if it is done in accordance with the specific characteristics of this bee. Absconding could be considered the most difficult management problem with this honeybee, but this character seems an obligatory survival strategy for this species when one considers its limited foraging range. Once the nectar supply within the foraging range depletes, it should change the foraging area. Therefore, it absconds, unless feeding is resorted to as an essential cultural practice. The shortage of nectar being the primary cause for absconding, the timing of supplementary feeding seems the most important factor in managing *A. cerana*. The empirical estimate of CPI will assist the beekeeper to decide on the time to feed rather than the elaborate examination of colonies for the protection from Wax Moths and Ants.

7.6. Supplementary Feeding

A desirable sugar solution for feeding could be prepared by adding 750 ml of hot water to 1 kg of sugar. This mixture yields about 1400 ml of syrup. This syrup could be fed with the use of any container but the 500 ml friction lid cans are more practical. There need be only a single hole in the lid for the bees to suck up the syrup (Fig 7.15). Especially when one is feeding small colonies, having a single hole is important, in order to prevent the syrup being robbed by large colonies from the neighbourhood. With a single hole in the feeder, the bees in a small colony can eliminate the outside bees coming to rob the feed, as there is only one feeding hole. In an apiary where there are several colonies of varying strength, it is better to feed them in the evening to prevent robbing.

The feeder filled with syrup should be closed and inverted over the top-bars or the frames with combs for the bees to feed from underneath (Fig 7.16). Feeding bees with open containers has been practiced by some beekeepers but this method has several disadvantages compared to closed containers. So it may be a better idea to feed in a closed container whenever possible.

Table 7.1: Response to Supplementary Feeding of Sugar in Honeybee Colonies at an Extremely High Stocking Rate of 17 Colonies per Hectare (1991 April to December. Horana, Sri Lanka).

Nest volume of the colony	1. Condition of the colony 2. Number of days required to build a new new comb	Average supplementary feeding rate per 10 day period n = Number of colonies [Total amount of sugar supplied during this 9 months period in paranthesis]
5 to 8 litres	1. Absconded	<200 ml (n = 9)
5 to 8 litres	1. Maintenance and very slow growth 2. More than 60 days	308 ± 28 ml (n = 38) [5.9 kg sugar per colony]
5 to 8 litres	1. Slow growth 2. about 28 days	383 ± 29 ml (n = 21) [7.3 kg sugar per colony]
8 to 16 litres	1. Growth 2. 14 to 21 days * Drone production and maintenance * Queen production was induced by increasing supplementary feeding rate by 50%	648 ± 87 ml (n = 5) [12.4 kg sugar per colony]
Over 16 litres	1. Fast growth 2. Less than 14 days * Drone production and maintenance * Queen production was induced by increasing supplementary feeding rate by 50%	811 ± 77 ml (n = 11) [15.5 kg sugar per colony]

It is necessary to have an extra super over the nest to keep the feeder cans (Fig 7.16). It is shown in the Figures in Section 5.3.3 that the inner-cover or the crown-board is always kept just above the nest area. But one should keep in mind that the inner-cover only demarcates the nest area and, if the colonies need to be fed, the inner cover should be above the empty super which contains the feeder in it. Supplementary feeding means an added cost of production and beekeeping is most successful in areas where it can be least. But one should also remember that supplementary feeding is a must to get large colonies with high populations of foraging bees, if one wants to produce a good amount of honey.

7.7. Other Aspects of Supplementary Feeding

7.7.1. Feeding Sugar

In many inhabited localities in Sri Lanka the major problem of maintaining honeybees is the lack of sufficient amounts of nectar due to the lack of nectar-yielding plants. However, the pollen supply seems adequate. Therefore supplementary feeding of colonies with sugar syrup is inevitable.

Data in Table 7.1 is given to show the various aspects of supplementary feeding from an experiment which was done in a situation with extremely high stocking rates, where 84 colonies of varying sizes were maintained in 5 hectares of land.

Many colonies could be maintained in an apiary but the cost of supplementary feeding will increase. Therefore it is more profitable to spread out the colonies through out the village so that cost of feeding could be minimized. Cost of feeding is a major recurrent expenditure. On the other hand, if one is interested in breeding bees, different levels of supplementary feeding can help to manoeuvre the population sizes and the production of queens and drones.

7.7.2. Feeding Pollen Substitutes

Under normal beekeeping conditions feeding with pollen substitutes is not necessary. However, if one is interested in breeding queens, especially during the dearth periods and when the colony densities are high, feeding pollen substitutes may be desirable.

During the lean periods, with an adequate supply of syrup a queen may lay between 350 to 500 eggs per day. However, all these eggs are not raised to become larvae. The proportion of eggs raised may be between 70% to 40%. But under poor conditions, this may even drop to zero. The workers eat the young larvae. To prevent this cannibalistic behaviour, it is important to give a protein substitute, as such, a pollen substitute (for proteins & vitamins,) is desirable. The recipe for a desirable pollen substitute is given below. However, one should keep in mind that a pollen substitute may not work under absconding circumstances. It works well only with colonies which get sufficient nectar or sugar syrup.

Table 7.2: Recipe for a Suitable Pollen Substitute.

Ingredient	Amount
1. Raw chicken eggs	250 g (5 whole eggs)
2. Sugar	350 g
3. Soybean flour	250 g
4. Honey	25 ml
5. Vitamin C (Ascorbic Acid)	100mg per 100g pollen substitute
6. Vitamin B complex	100mg per 100g pollen substitute

Important: All ingredients should be very well mixed to make a fine homogenous paste.

As shown in Figure 7.17 a semi-solid pollen substitute could be fed with the use of a polyethylene film. About 200 g of pollen substitute spread on a polyethylene film covered with a piece of paper is inverted over the brood combs. The paper should be below and the polyethylene film should be on top. The bees from the bottom will tear through the paper and will consume the pollen substitute. The pollen substitute should be spread to a thickness of about 5 mm and the bees should completely consume it within 5 - 7 days. If the bees do not consume it within that time, either the amount is too much for them or the bees are in preparation for absconding. If the bees are preparing to abscond it is easy to see the pollen substitute being dropped to the floor board. The floor board may accumulate the tiny pieces of torn-out paper. Therefore it is important that the beekeeper should be able to distinguish between torn-out paper from the thrown out pollen substitute which consists now of dried soybean flour after the sugary liquid has been sucked up.

7.8. Other Animals Associated with the Nest of Mee Bees and their Pest Status

Our Mee Bee is well adapted to the local environment on which it evolved for the past millions of years and it does not have any note worthy pestilence. However, we all know that, on some occasions insects such as **Hornets, Wax Moths, Ants**, Reptiles such as **Geckos and Garden Lizards**, Large **Spiders, Scorpions** and **Birds** such as **Bee Eaters, Drongos** etc., can inflict considerable injury on bees. Mee bees fall prey to these animals only when they are starving or in an alien environment.

Predation by birds such as Bee Eaters (Family: *Meropidae*) and Drongoes (Family: *Dicruridae*) is a good example of the injury caused in an alien environment. There are three species of Bee Eaters and Four species of Drongos in Sri Lanka and all of them or some of them are found in any part of Sri Lanka. These birds are strong flies and catch their prey while

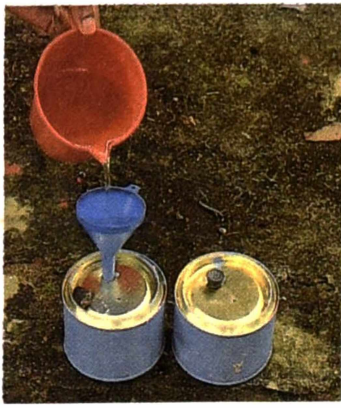

Figure 7.15: Filling 500ml of sugar syrup to a feeder with a single hole for feeding.

(The black Rubber stopper is used to close the larger filling hole. The smaller feeding hole is located to the right of the Rubber stopper.)



Figure 7.16:

Feeding can be inverted over the frames (or top-bars) of the upper part of the nest. Note the empty super to keep the feeder.



Figure 7.17: A pollen substitute being fed to a colony. The pollen substitute, which is a thick paste spread to about 5mm thick layer between a polythylene film on top and a piece of news paper below. Once this pollen substitute is given to a colony, the bees would cut through the paper from the lower side and begin to consume the nutritive paste. Normally it would take about 7 days for a colony with 6-8 brood combs to consume 200g of such a paste. Here the bees have almost completely consumed the paste kept on top of brood combs. Some fragments of the unremoved paper still attached to the paste is visible.

in flight in open areas. Therefore, the bees will fall prey to these birds when they have to fly through wide open spaces or the hives are kept in open areas. Our Mee Bee is well adapted to fly through foliage and tree canopies, perhaps to avoid predation by birds. In fact one good example of our bee's ability to fly among tree canopies is that the formation of Drone Congregation Areas (DCA) among canopies of trees (see Figure 10.3 p. 204) which may be an adaptation to avoid predation. The avoidance of insectivorous predation is important for the worker bees who has to fly through out the day light period as much as for the drones who fly only during a certain specific time period of the day. Therefore, hives should be placed in areas such that the entrance or the flight path in and out of the hives should not be exposed to wide open spaces. Infact garden Lizards approach the hives to feed on bees only when the hives are exposed to open spaces. As such the beekeepers should make every attempt to provide the bees with shelter and protection with the naturally occurring factors.

The Asiatic bee mite *Varroa* (*Varroa jacobsoni*: Varroidae: Arachnida) which was introduced to Europe in the recent past had become highly destructive to the exotic vector the Western honeybee (*Apis mellifera*) but does not show any detrimental effects on the natural vector Asiatic honeybee (*A. cerana*)². *Varroa* mite affects mildly on the drone brood of *A. cerana* and in fact it is not even obvious to many of us. Really speaking it is difficult even for a beekeeper to find *Varroa* mites in a colony. In many instances a flower mite which becomes common during certain times of the year has been mis-identified as *Varroa*. This flower mite, a phoretic symbiont is harmless to bees and it uses honeybees as a vehicle to disperse itself from flower to flower (see Figure 7.18).

In the same manner where the *Varroa* mite, a minor-parasite of the Asiatic honeybee has turned out to be a major-parasite in the Western honeybee; the diseases of the Western honeybee can be devastating to our honeybee or Mee Bee. Already such problems have sprung up in places where the Western honeybee has been introduced and it has caused the beekeepers in such situations to resort to the use of medications or chemotherapy where expensive drugs have to be used. Under such circumstances, the honey which is considered as a clean product of the nature is liable to get contaminated from those chemicals used as therapeutic agents. Fortunately in Sri Lanka we do not have such a problem and all concerned with honey and honeybees should make every effort to keep our present favourable situation unchanged.

On examining the animals associated with honeybee nests in Sri Lanka. *Tarentula* (*Divimakaluwa*, a type of a very large spider but not a real *Tarentula*) and other spiders, small white Scorpions (*Kiri Gonussa*), Geckos (*Huna*), other insectivorous insects etc., are not uncommon to find in close vicinity. But none of them are known to behave as major predator of bees and they seem to exist in harmony with those of the bees nest. Undoubtedly a few bees may fall prey to these predatory animals daily and in any case several hundreds of bees will

²Koeniger, N & Koeniger, G (1985) Change of host by parasitic mites in Asia after a new honeybee species is introduced. Proc. 3rd Internat. Conf. Apiculture in Tropical Climates, 1984 Nairobi. Kenya. p. 160-162. IBRA, UK.

Koeniger, N; Koeniger, G & Wijayagunsekara, HNP (1980) Beobachtungen uber die Anpassung von *Varroa jacobsoni* and ihren natuerlichen Wirt *Apis cerana* in Sri Lanka, Apidologie 12:37-40.

naturally be lost per day. The life span of a single worker bee is only a few weeks and the queen lays constantly to replace the lost ones.

As such our honeybee or Mee Bee is in perfect harmony with its natural enemies and these will intrude only when conditions are in their favour. Therefore, it is the responsibility of the beekeeper to maintain the environmental conditions in such a way that it is in perfect agreement with the natural requirements of the bees.

However, the most devastating threat faced by our bee is the detrimental influence created by the action of Man on his environment. All of us will have to find the way, and means to keep these detrimental effects at a minimum, especially the use of **xenobiotics as agrochemicals** has to be made with much care. These being xenobiotics they have the capacity not only to destroy the target pest organisms (in this instance an insect pest, a disease causing Fungi or a weedy plant) but may destroy other living organisms in the environment. Therefore, in the use of pesticides one has to be very careful about the amounts, time periods and the methods of dispersing these xenobiotics in the environment.

The protection of food plants of the bees and the provision of nesting sites for bees are also important aspects of environmental conservation.

The sustainability and stability of an agro- or any other eco-system depends on the diversity of species that it contains. What is important in sustainable agriculture or conservation farming is to conserve the species diversity in the eco-system. Honeybees and other wild bees help immensely in maintaining the stability of an eco-system as pollinators of plants. Today the greatest challenge to this stability has come from the use of pesticides that are dispersed in the environment. An agro-ecosystem with lesser diversity is less stable than a natural ecosystem and therefore vulnerable to invasion by other plants (which we call weeds), invasion by other insects (which we call insect pests) and invasion by micro-organisms (which we call diseases due to Fungi, Bacteria etc.). By using the xenobiotics to control pestilence we are making the ecosystem still weaker and now it is well known that the use of pesticides will create long term detrimental effects. Now it is increasingly becoming evident that the use of mixed cropping patterns (as opposed to mono-culture) has many beneficial effects in sustaining the stability of the eco-system.

Therefore, beekeepers who are dependent on the environment should be more concerned with the environmental conservation. On the other hand, as discussed previously many of the problems of beekeeping are due to the environmental deficiencies.

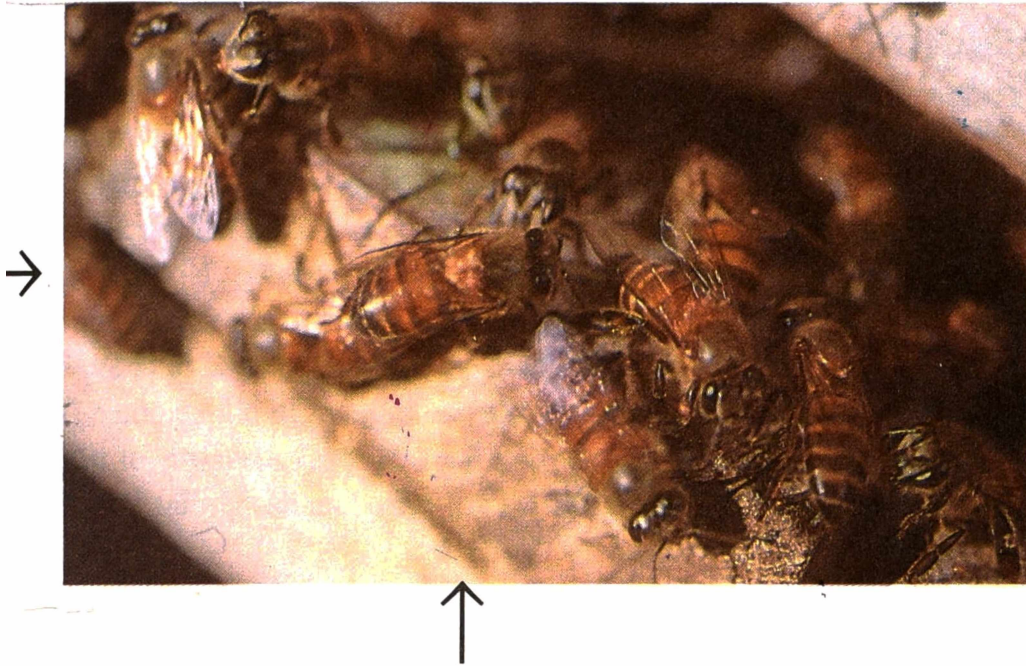

Figure 7.18: A wagging bee or a shaking bee at the hive entrance. Note the small light coloured cluster of tiny mites on the rear end of its thorax (project the arrows inside to locate the position). This bee is wagging its body to invite one of its nest mates to come and clear the mites. Another bee approaching the wagging bee is seen. These mites on the body of the bees are a free living species of mites called *Neocypholaelaps indica* (Acarina) and they are feeding on flower pollen. These mites use bees as a transport agent or a phoretic symbiont to go from flower to flower. Such wagging bees are a common site during certain periods of the year when certain types of flower are abundant.

8. Smoking

8.1. Smoker

Perhaps from time immemorial, Man knew that smoke has a controlling effect on honeybees and used smoke to drive away the bees when he was plundering their colonies. Often fire was used to destroy bees, such as in situations where colonies of Bambara Bees (*Apis dorsata*) were plundered. The effect of smoke on bees was discussed in section 1.5.3.1.

Smoking is an essential requirement in successful beekeeping and as such the apparatus used for this purpose is usually referred to as the "smoker". The inside of a smoker is illustrated in Figure 8.1. Any suitable material which can generate a mild smoke, such as wood shavings, Coconut husk, cardboard paper, etc., can be used to generate smoke. Whatever be the material used in the smoker, once it is kindled, it should be inserted into the burning chamber and the burning end of the material should be held downwards so that the burning will progress upwards. At the start, a few puffs of air from a bellows will help the burning to progress. What is important here is to have currents of air going through the burning material inside the burning chamber. The conical lid of the ignited smoker, when it is not being used, could be left open for the burning to progress fast. The air chamber below the perforated plate should always be kept free from falling ash and other debris for the proper functioning of the smoker.

A smoker is basically a device to generate some smoke and it can be of any suitable shape and kind. The simplest smoker such as a section of a Coconut husk burning at one end (see Figure 8.2), will generate a good smoke for a 15 to 20 minute period. What is advantageous in a smoker with attached bellows is that the smoke can be directed to any desired direction and can generate enough smoke as and when necessary (see Figure 8.3). Such a smoker is a valuable asset in beekeeping.

8.2. Smoking

Beekeepers use different methods to smoke hives before examining the colony and these are time tested and good. What is important in smoking is first to know the purpose of examining the hive. For instance, if the hive is examined to see the honey build-up in supers, one can simply separate the supers above the one that needs to be examined and send the smoke directly to that super to clear the bees from combs and then look in and pull out the combs if necessary.

Smoking can be detrimental to the bees if the smoke is hot. Hot smoke will irritate the bees and provoke their stinging reaction. Therefore one should remember to use cool smoke. As a practice the smoker should be held about 25 - 30 cm away from the bees to prevent hot smoke being blown on them. Bees move away from cool smoke but react violently against hot smoke.

If the purpose of examining the hive is to look for the queen to separate her for colony dividing, the procedure should be different. In such a situation, smoke should not be first directed at the hive entrance. If this is done it often makes the queen move to the supers, and finding her becomes a long and tiresome task. For the purpose of finding the queen, first the supers should be separated from the brood box and then the smoke should be sent to the top-bars of the brood combs. Afterwards, a few puffs can be directed at the entrance. This makes bees sufficiently smoked and as each comb is pulled out, some more smoke can be sent to subdue the bees further.

One has to remember not to over smoke since over-smoking will agitate the bees, thoroughly who will start running around which makes finding the queen very difficult.

If one wants to see the brood combs to determine the stage of growth in the brood box, it could be placed directly on a mirror box and smoke could be sent from below directly at the brood combs. This makes the bees move up, exposing the ends of brood combs where drone brood or queen cells could easily be seen (see Section 6.2 and Figures 6.6 & 6.7 for details).

Smoker with Bellows

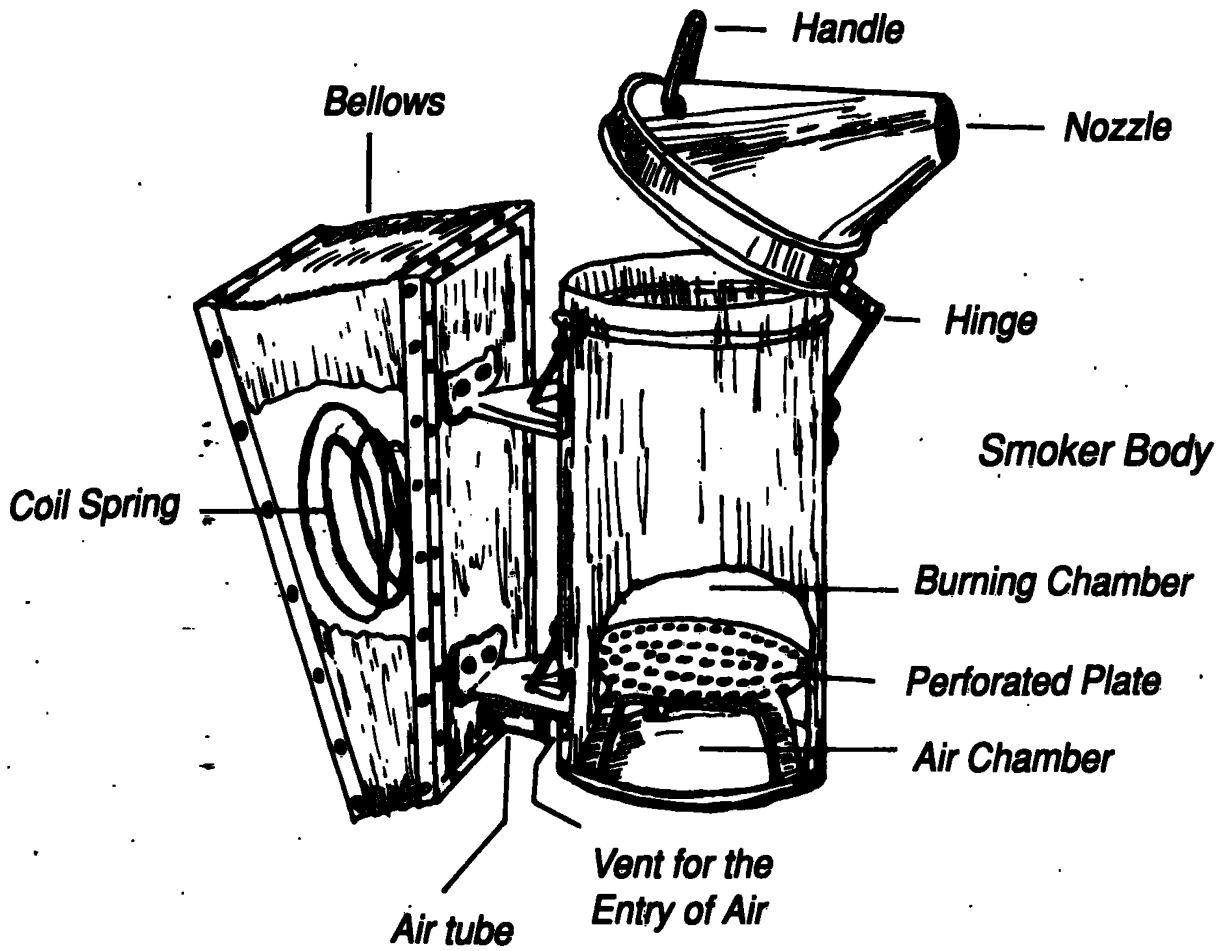

Scale: about $\frac{1}{2.5}$

Figure 8.1: Different parts of an effective smoker with bellows.

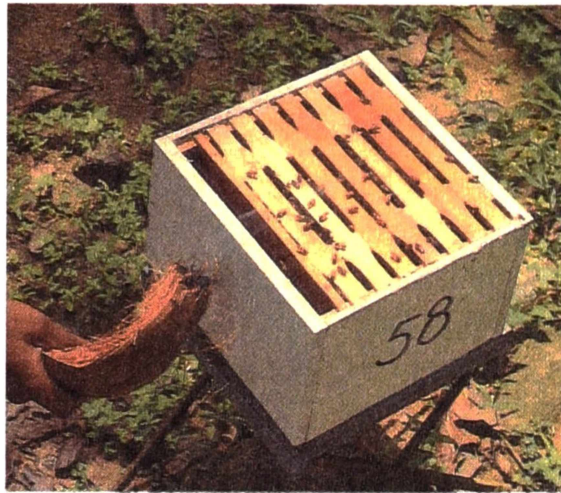

Figure 8.2: Smoking with a section of a Coconut husk. Here the main difficulties are to direct the smoke where it is needed and to generate a lot of smoke when necessary.



Figure 8.3: Sending some smoke above the combs will calm down the bees and make the brood box examination easier. A smoker with bellows is more effective.

9. Honey Extraction

9.1. A Honey-Flow

A honey-flow is the time period during which one or several species of plants in an area secrete nectar at a level which is over and above the normal maintenance, growth and reproductive requirements of honeybee colonies in the vicinity. Therefore, this nectar will get collected (stored) in honeybee colonies as Honey. This is the time period in which honey is available in honeybee colonies for harvesting.

Fruit trees bear only once a year in most cases and therefore most of the fruits are seasonal. Honey-flow in an area too is seasonal or annual. Therefore all the effort that has gone to manage honeybees during the non productive period has to be compensated for during the honey-flow period and the investment recovered.

Usually a honey-flow will last for 4 to 6 weeks. Due to climatic changes such as early rain, etc., the duration of a honey-flow can be as short as 3 weeks then the yield for that year will be poor. Similarly, honey-flow may extend up to 8 weeks in some years and during these better years beekeepers can harvest more honey. Usually the honey-flow from **Rubber** (*Hevea brasiliensis*: Euphobiaceae) lasts for about 6 weeks from the end of February to early April and the honey-flow from **Red Gum** (*Eucalyptus robusta*: Myrtaceae) lasts a similar period from mid August till the end of September.

9.2. Honey Stores in a Nest of Bees

Honey is stored in the upper most parts of combs in a colony of honeybees. In a moveable comb hive if supers are provided with empty combs for the collection of honey, first the honey gets collected in the super combs closest to the brood chamber and gradually extends upwards. In Figure 9.1 the cross section of the honey store distribution in a honeybees' nest is shown. Therefore, the mature honey gets stored first in the super next to the brood chamber and this is called the first super. A well-managed colony may have up to 6 supers or more. The maturity of the honey decreases as it extends to the upper most supers. Here what we mean by maturity of the honey is the water content. When the bees have succeeded in reducing the water content by fanning, they will seal with wax the cells which contain the mature honey. Ideally, the mature honey will have between 18% to 19% water and such honey will not ferment during storage.

During the honey-flow mature honey first appears in the first super within about a week from the commencement of the flow (Figure 9.2). If the colony has 4 supers or more, it is not unusual to find that all the honey combs in both 1st & 2nd supers are sealed and ready for extraction. And such sealed combs should be extracted immediately.

What is important is to remove the honey as soon as the honey combs are sealed. The supers that were extracted now with empty combs should then go to the top and supers with partly filled combs should be put in their place. As explained in Figure 9.3 the supers should be circulated.

With a well managed colony (such as one with 4 supers or more), it is possible to extract at least a single super every 5 to 7 days during a normal honey-flow which lasts for about 5 weeks. This can give a yield well over 10 kg per hive per year.

9.3. Removal of Honey

For examination of colonies during the honey season, one should separate the other hive parts from the 2nd super. This makes it possible to examine the first super and if the first super contains sealed honey combs, the second too should be examined until all the supers with sealed honey are recognized for removal of honey. These supers should now be removed and placed at the top of the hive and a few puffs of smoke be sent to drive the bees down. Make sure not to over-smoke them.

The supers now devoid of bees should be removed to the honey extraction site which may be a few meters away from the hive (Figure 9.4). The few bees remaining on combs could be brushed off with the use of a bee brush (see Figure 6.16) just before uncapping. At the extraction site, the sealed combs should be uncapped with a knife while holding the comb frame over a strainer placed on a collection vessel (Figure 9.4). This keeps the dripping honey free from wax fragments, and avoids spillage and waste. The uncapped combs are put in the centrifugal extractor and spinned to remove the honey (Figure 9.5). During the first spinning the extractor will remove honey only from the side of the comb which faces the barrel or the extractor body. To remove the honey on the other side, the combs have to be turned again, so that the side from which honey has not been removed will now face the barrel.

If the honey is to be extracted in the field, one has to be very quick as the bees may become a nuisance if they start coming to the extraction site. So one has to keep every thing ready and in place before starting to uncap the honey combs. It is a good idea to keep the smoker going at the extraction site to prevent bees coming there. Keep the lid of the smoker open and add pieces of coconut husk from time to time to keep it going. Make sure not to have flames but just smoke.

The honey extraction should be planned in such as to remove only a maximum of two supers only at a time and not more. This will help in reducing the time spent in extracting honey, because the more time is spent the likelihood of bees becoming a nuisance is also greater. When the honey is removed as soon as it has been sealed, it will help to relieve congestion in the hive and increase the availability of space which in turn, will help to get better yields.



Figure 9.1: The distribution of honey stores in a nest of Mee Bees (hive honeybees). The band of pollen stores in the combs of the brood nest (or brood chamber in a hive) clearly divide the Honey stores above and Brood nest below.

above is the Honey Stores
 ← The Pollen Stores
 below is the Brood Nest



Figure 9.2: The first super (left, yellow coloured) contains mature sealed honey ready to be extracted. The second super (right, white coloured) that was on top contains only immature unsealed honey not suitable for extraction yet.

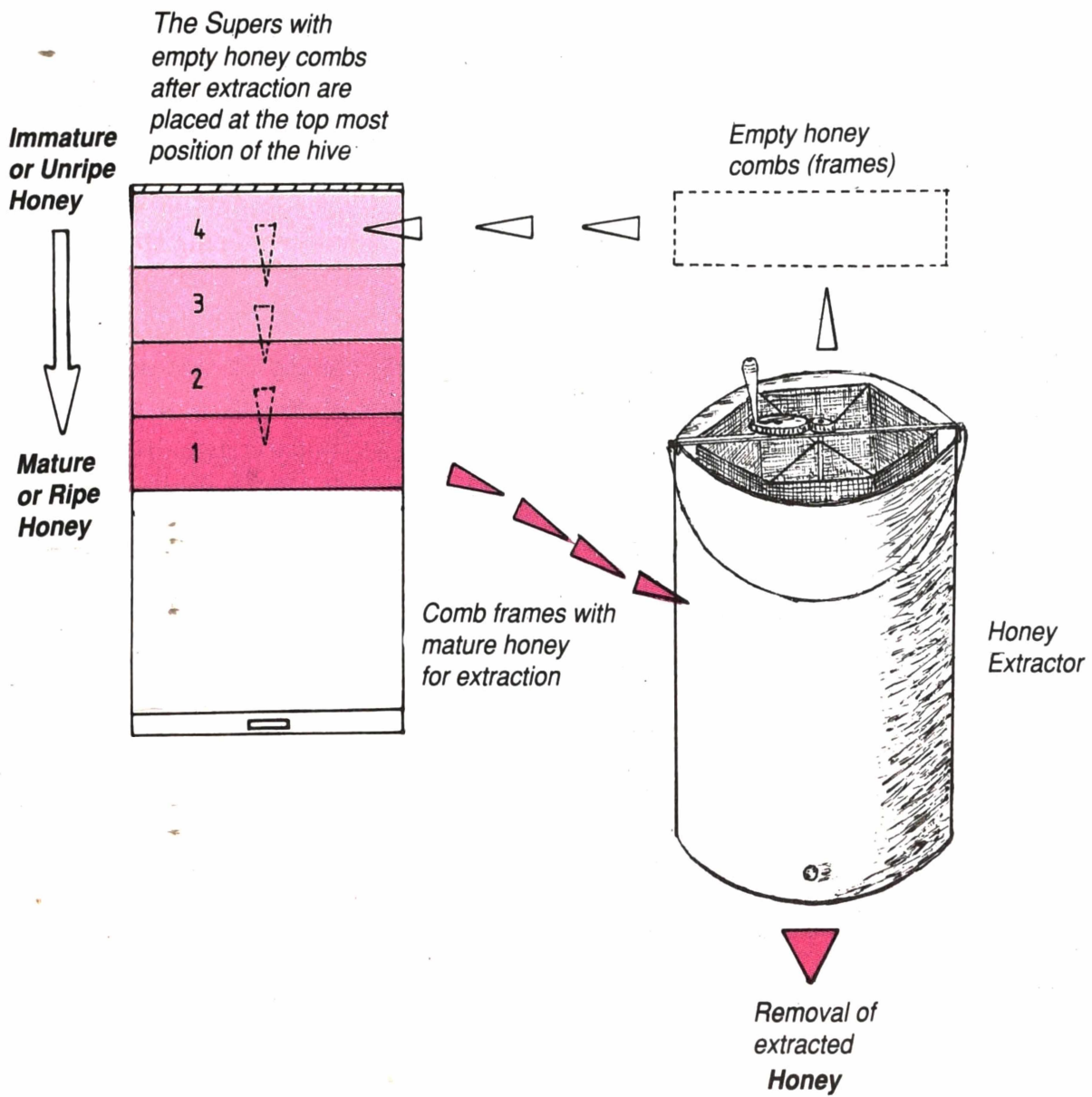

Figure 9.3: Honey extraction procedure: The first super with mature honey should be extracted first. Once honey is taken out, the empty super should be returned to the top most or the last (4th) position.

The supers with empty combs should be returned to the hive at the top-most position in the hive, so that the 1st super before becomes the last super after the extraction of honey. The procedure of extraction of honey from honey combs (or supers) and their return to the hive is explained in Figure 9.3.

9.4. Honey Extractor

The essential parts are described in Figure 9.5. The present extractor can hold 6 honey combs at a time. The honey that gets thrown out from de-capped honey combs when the handle is turned will get collected at the slanting bottom which has an out-let tube at the lowest level. This facilitates the removal of all the honey without any portion left un-removed. This out-let should be plugged (usually with a rubber stopper) while the combs are being spun.

It is important to wash the extractor soon after extracting honey on each day. Do not use any detergent or soap in washing. Use only clean cold water and place it up-side-down to drain all the remaining water. Otherwise, the remaining layer of honey on extractor metal parts will taint the honey that will be extracted later. The extractor body is usually turned out of galvanised iron sheets. Therefore, it is a good idea to coat the inside of the extractor with melted bees' wax (either Mee Bees' or Bambara Bees' wax can be used) for durability and prevention of any possible tainting of honey. Do not apply any anticorrosive paints or enamel paints on the parts of the extractor which comes in contact with the honey.



Figure 9.4: Extraction of Honey in the Apiary.

- Uncapping (removal of the wax sealing) the honey combs while holding over a strainer for extraction. Dripping honey will be collected in the vessel below the strainer will retain all the wax pieces. A honey comb frame to be uncapped on top of the hive.
- Note the smoker giving a smoke.
- Portable centrifugal honey extractor filled with uncapped honey frames ready to be rotated for extraction of the honey.
- The white coloured plastic vessels on the right foreground, are for the collection of honey from the extractor.
- After extraction of honey, the empty honey comb frames are kept at the top most position as explained in Figure 9.3. Note now the yellow super takes the last position (3rd super).

Portable Honey Extractor

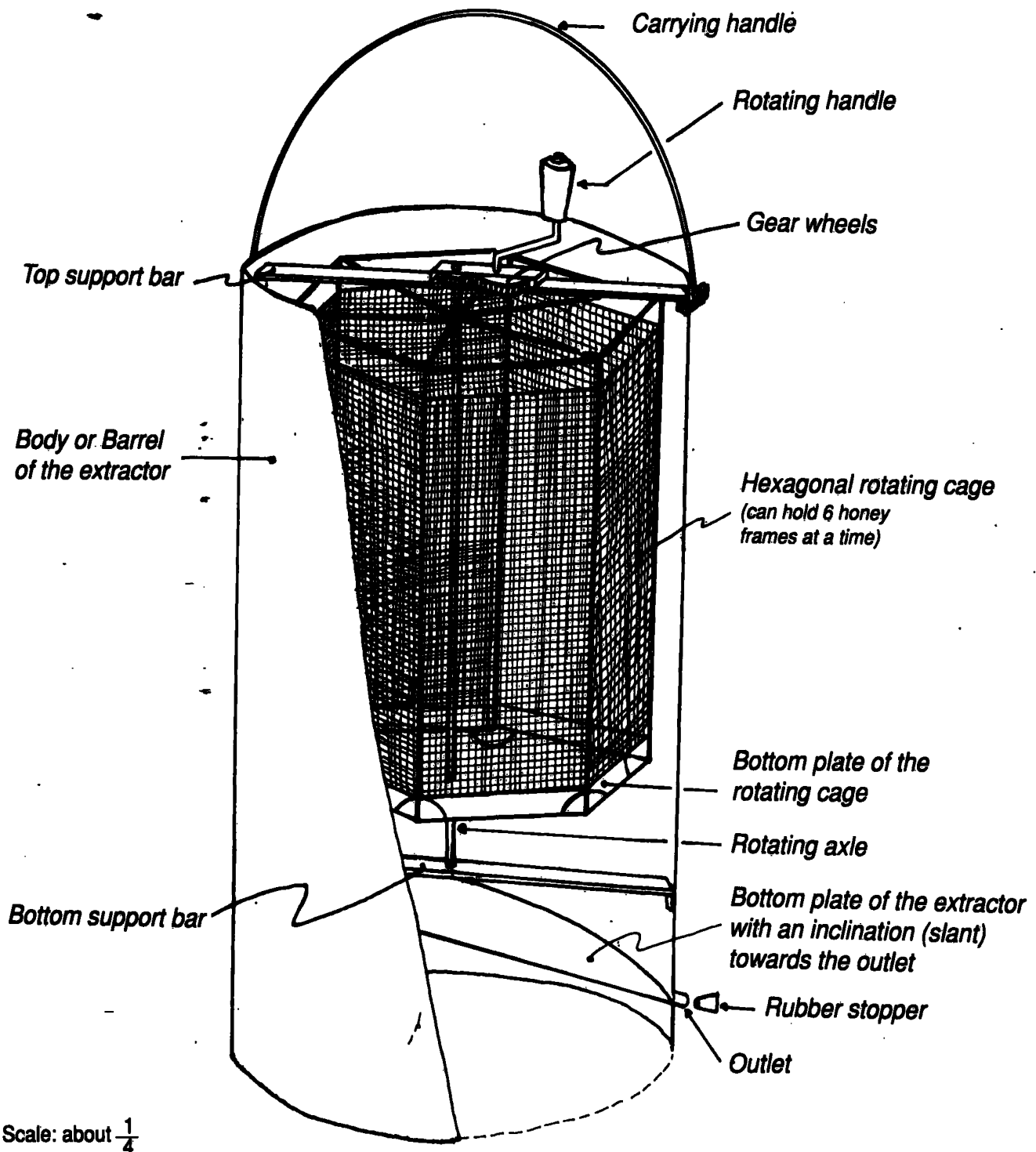

Figure 9.5: Details of a suitable portable honey extractor that is capable of holding 6 honey frames at a time. The handle help in its portability and such an extractor can be very handy.

10. Economics of Beekeeping

10.1. How to Start Beekeeping with Mee Bees

A beginner who wants to start beekeeping should have a clear understanding about the ways of the honeybees, his or her own capabilities and the environmental potential of the area intended for producing honey. It is emphasized that a beginner should have undergone training with an experienced beekeeper for at least 6 months. Of this training period 2 months should be during the dearth period on various aspects in management especially under the absconding impulse, another 2 months prior to the honey-flow season on aspects of management on swarming behaviour and production of new colonies and 2 months during the honey-flow period on honey extraction and colony maintenance. Even though one undergoes such a training period it is important to be able to get advice from an experienced beekeeper as and when necessary until full competency is gained. Therefore the possibility of associating with one or more beekeepers operating close to one's area is important. The Department of Agricultural Office, usually based at the regional Agrarian Service Centres or the Sri Lanka Bee Farmers' Association will be able to help in locating the Beekeepers of a particular area.

■ A district office of the **Sri Lanka Department of Agriculture** is situated in the major city of each **District** and a **Regional Agricultural Office** is at every regional Agrarian Service Centre to get information.

■ The present address of the **Sri Lanka Bee Farmers' Association** is

Sri Lanka Bee Farmers' Association,
- C/o, Natural Science Division,
National Museum,
Colombo 7.

■ In the **Horticultural Research and Development Institute** of the **Sri Lanka Dept. of Agriculture** at Peradeniya, there is a central unit for coordinating all activities related to Apiculture in Sri Lanka. The address is

Central Apiculture Unit,
Horticultural Research and Development Institute,
Gannoruwa,
Peradeniya.

This **Central Apiculture Unit** has a mandate to coordinate Beekeeping training requirements, maintaining inventory of Beekeepers in the Island, identification of Beekeeping problems, designing and directing National Research and Developments in Beekeeping, quality control & certification of manufacturers in beekeeping equipment and coordination of Beekeeping equipment supply.

A beginner should be careful about the number of colonies he or she wishes to maintain. He or she should neither attempt to keep a single colony nor try to keep more than five colonies. It is prudent to maintain only 2 or 3 colonies at the beginning till one is experienced enough. One of the major problem in managing the Mee Bee is the problem of absconding (see Chapter 7) and this can take place at any time. It is important to be able to obtain brood combs from elsewhere for the management of colonies getting into absconding phase and this necessity can most effectively be fulfilled only if one has another colony to supply them. It may also be handy to have an extra empty hive.

10.2. How Much Honey to be Produced ?

Beekeeping can be done profitably by anyone who is living in areas of good honey-flow conditions and is able to handle bees. In fact quite a number of our beekeepers do exist in such areas. Honey is produced from varying types of hives ranging from simple clay pots and logs to expensive movable comb hives.

On an average many beekeepers produce about 2 kg of honey during the season without much effort. At the same time there are many beekeepers who do not produce any. It is often thought that the modern movable comb hives will help to increase the yields. In a broad sense this may be so !. But one should remember that the modern hive by itself is no better than the simple pot or the log hive, as regards the increase in yield. What modern movable comb hives offer is the facility to manage the bees more efficiently to produce higher yields. Modern hives demand better knowledge about bees, more investment and higher managerial skills on the part of the beekeeper. If these conditions on the part of the beekeeper are fulfilled the movable comb hives are very advantageous.

Like in many modernized agricultural production systems, modernization and efficiency demand investment, which means money and skills. For example, the new breeds of high yielding varieties of Rice, as many of us know well, demand many inputs and better management from the farmers to give the best results. This is so with beekeeping too. Many inputs and better management are demanded from beekeepers for the best results. The preceding chapters covered the essential management practices and here we try to look at the profitability of beekeeping.

In this Chapter, in calculating the profits and losses more emphasis is given to the expenditure aspect than to the income aspect. Considered from this point of view during the first year an operation with 10 hives producing a minimum of 10 kg of honey per hive should break-even (see Tables 10.1 to 10.4). The main expenditure will be for the investment on hives, honey extractors and smokers. One should remember that, under the honey production systems discussed in this work, the smokers and honey extractors become essential, if one is thinking of using movable comb hives. A single honey extractor and a smoker can serve a large number of colonies. Therefore, to get the maximum benefit of these appliances, there has to be an increase in the number of colonies one is managing. This again requires further investment in terms of hives and colonies.

If appliances such as smokers and honey extractors could be shared among several beekeepers in a village, the initial capital would be reduced. But it is important to keep in mind that often decisions on management steps that should be taken with regard to colonies has to be done almost instantaneously with very little or no time for planning. Therefore, although one may have to share the appliances at the beginning for reasons of economy, in the long run, it may be advantageous for each beekeeper to have his own appliances at his disposal.

In the context of the above facts, it becomes clear that a profit-oriented beekeeping operation for honey production demands a sizable investment. Therefore, it is equally important that management should be fully planned to the maximum possible yield.

Tables 10.1 to 10.4 are presented here as a guideline for directing the beekeepers to a profit oriented production process. The steps involved in calculating the cost and returns can vary depending on different situations. However one should be concerned with the returns for the investment apart from the other non-monetary and immeasurable beneficial effects of rearing Mee Bees, such as recreational, environmental, etc. A guide for investment in terms of labour and time is given in Table 10.5 (p.190).

මියක් කඩන්නේ අත ලෙට් කෑමට නොවේ

"one plunders a nest of honeybees not for licking the hands"

- a Singhala proverb

One should indulge only in fruitful activities.

Table 10.1: Cost and Returns From Honey Production Depending on Different Apiary Sizes (Management done with a view to recovering all costs during the first year of operation).

First year

Apiary Size	5 hives	10 hives	15 hives	20 hives	25 hives
Expenditure (Rupees)					
Cost of hives (Rs.300 per hive)	1,500	3,000	4,500	6,000	7,500
Cost of colonies (Rs. 200 per colony)	1,000	2,000	3,000	4,000	5,000
Honey Extractor	600	600	600	600	600
Smoker	300	300	300	300	300
Supplementary Feeding (4 kg sugar per colony per year)	500	1,000	1,500	2,000	2,500
Incidentals	250	500	750	1,000	1,250
Sub Total	4,150	7,400	10,650	13,680	17,150
Total Expenditure (with 20% added for interest)	4,980	8,880	12,780	16,680	20,580
Income (Rupees)					
Sale of Honey (target yield 10 kg per hive & Rs 100 per kg)	5,000	10,000	15,000	20,000	25,000
Sale of Colonies (Rs 100 per colony)	500	1,000	1,500	2,000	2,500
Expected Annual Income	5,500	11,000	16,500	22,000	27,500
Actual Income (with 20% less due to market problems)	4,400	8,800	13,200	17,600	22,000
Profit + / Loss =	- 580	- 80	+ 420	+ 920	+ 1,420

Table 10.2: Cost and Returns From Honey Production Depending on Different Apiary Sizes in the Second Year of Operation (Management done assuming that all costs were recovered during the first year of operation).

Second Year

Apiary Size	5 hives	10 hives	15 hives	20 hives	25 hives
Expenditure (Rupees)					
Supplementary Feeding (4 kg sugar per colony per year)	500	1,000	1,500	2,000	2,500
Incidentals	250	500	750	1,000	1,250
Contingencies	250	500	750	1,000	1,250
Losses in the first year	580	80	-	-	-
Total Expenditure (with 20% interest)	1,896	2,496	3,600	4,800	6,000
Income (Rupees)					
Sale of Honey (assuming a 20% loss in yield or income)	4,000	8,000	12,000	16,000	20,000
Profit - 1	2,104	5,504	8,400	11,200	14,000
Sale of Colonies (Rs 100 per colony)	500	1,000	1,500	2,000	2,500
Total Income	4,500	9,000	13,500	18,000	22,500
Profit - 2	2,604	6,504	9,900	13,200	16,500

Table 10.3: Cost and Returns From Honey Production With a Beekeeper Starting With an Apiary of 10 Colonies in the First Year and Increasing the Apiary Size by 50% or 100% in the Second Year (Assuming that all costs were recovered during the first year of operation).

Second Year

Number of Hives	15 Hives (50% increase)	20 Hives (100% increase)
Expenditure (Rupees)		
Income lost in the 1st year by not selling colonies	500	1,000
Losses in Profit	80	80
Purchase of new hives	1,500	3,000
Supplementary feeding	1,500	2,000
Incidentals and contingencies	1,500	2,000
Sub Total	5,080	8,080
Total Expenditure (with 20% interest)	6,096	9,696
Income (Rupees)		
Sale of Honey (Rs 100 per kg)	15,000	20,000
Sale of Colonies (Rs 100 per colony)	1,500	2,000
Expected Income	16,500	22,000
Actual Income (20% less due to marketing problems)	13,200	17,600
Profit	7,104	7,904

Table 10.4: Cost and Returns From Beekeeping Operation in Table 10.3 When Continued to Third Year Without Changing the Apiary Size

Third Year

Number of Colonies (unchanged)	15 Hives	20 Hives
Expenditure (Rupees)		
Supplementary Feeding	1,500	2,000
Incidentals & Contingencies	1,500	2,000
Sub Total	3,000	4,000
Total Expenditure (with 20% interest)	3,600	4,800
Income (Rupees)		
By sale of Honey (Rs 100 per kg)	15,000	20,000
By sale of Colonies (Rs 100 per Colony)	1,500	2,000
Expected Income	16,500	22,000
Actual Income (with a reduction of 20 % due to market problem)	13,200	17,600
Profit	9,600	12,800

10.3. How much Honey Do We Need and For What Purpose?

In Sri Lanka, honey plays an important role as a common ingredient in the traditional medical practice. Honey is not considered as an item in the Sri Lankan diet but is more valued as a medicinal food.

Collection of honey from wild colonies had been the main source of supply in the ancient past as much as it is today. It could be estimated that about 25 tons are produced locally where more than, 10 tons come from honey-hunting. On an average, annually 20 tons are imported¹ mainly from Australia. Of the imported honey, almost 90% goes for the indigenous (ayurvedic) medicinal preparations². The present requirement for medically-related purposes is about 100 tons per year and thus the demand for honey is high. If produced in sufficient quantities over and above the requirement for medically-related uses, honey can be used as a common food ingredient like jam.

10.4. Apiary Layout

It was discussed previously that the Sri Lankan hive honeybee, *Apis cerana indica* has rather a short flight range. Its average foraging range is around a radius of about 300 m from its hive. Therefore beekeepers should not try to keep all or most of the colonies in a single site or at only a few locations since this leads to lowering of honey yields and an increase in the supplementary feeding costs.

As a practical and a viable alternative, a beekeeper can spread out his colonies throughout the village to reduce the competition for food by the colonies and this is particularly useful during the dearth and growth period to cut down on the cost of feeding. Similar operations are common in rearing cattle where most of the cattle-owners do not have their own pasture-land, but the animals are taken for grazing to the lands in the neighbourhood or the farmer cuts the fodder from elsewhere and brings it to the cattle shed.

There is no hard and fast rule about the apiary layout and it all depends on each individual situation. However, for an apiarist in a village it could be said that the furthestmost colony should be in a place where he can reach it in about 20 minutes by walking from his house (i.e about 2 km away). Some concepts on foraging range related to the apiary layout were discussed in Section 2.3.

¹ Sri Lanka Customs, External Trade Statistics 1985-1989, Colombo, Sri Lanka.

² Information Provided by the Ayurvedic Drugs Manufacturing Plant, Nawinna, Maharagama, Sri Lanka.

10.5. The Environmental and Socio-Economic Basis of Beekeeping

Evidence to suggest that Beekeeping was a traditional industry in Sri Lanka is still lacking, in spite of the fact that honey was used extensively in traditional medical practice, and was a much valued item in food. However, collection of honey from wild bee colonies has been practised since time immemorial with much legend attached to it. The management of honeybees was essentially a Western introduction to our country in the latter part of the 19th century and often during this period even the Western honeybees were introduced. The widespread popularity of beekeeping the world-over was due to the discovery of "bee space" in the United States by Rev. LL Langstroth in 1850s. This made the foundation for a new industry world-wide with the use of movable comb (frame) hives.

Our honeybee, *Apis cerana indica*, is often maligned as a low productive and problematic species, especially compared to her Western counterpart *Apis mellifera*. No doubt *A. mellifera* is a good honey producer. But in tropical Asia, *A. mellifera* requires lot of attention and care for desired performance. It encounters many problems such as attacks from *Varroa mites*, bee-eating birds, predation by hornets, etc. in a tropical environment. Therefore costly chemical treatment and other protective measures are necessary for the success of honey production with *A. mellifera*. Further, *A. mellifera* has her own brood diseases that requires medication. The brood diseases of *A. mellifera* can be devastating to our honeybee *A. cerana* as was demonstrated in other tropical Asian countries. This treatment may cause contamination of honey and progressively conditions become worse.

Fortunately, in Sri Lanka, we neither have *A. mellifera* nor the problems that come with her. *A. mellifera* that was introduced in the past may have died out due to inadequate attention.

Our honeybee who has co-evolved with her indigenous natural enemies, knows how to deal with them and lives in perfect harmony with them. It is also a point of extreme importance to remember that our honeybee has evolved in our tropical monsoonal forest which is very rich in plant species and in density. So in the thick natural forest, they have a great variety and abundance of forage. Therefore it was not necessary to have a large foraging flight range and as such they forage in a rather small area. The foraging range of the Western honeybee extends to several kilometers while for our honeybee, it is about 300 meters. The Western honeybee which evolved in the temperate climate, perhaps had to have a long foraging area to get enough food for the long winters while our honeybee evolved in the evergreen (and ever-flowering) tropical forest had no such environmental pressure.

Therefore, when our honeybee *A. cerana* lives in human habitations, the food supply obviously become lean and they are often hungry. Their frequent hunger makes them weak, prone to pest attacks and therefore low-productive. Then supplementary feeding becomes an important issue in managing them. For high productivity, supplementary feeding is a must even with *A. mellifera* since it is necessary to get a large population just before a honey-flow in spite of its long foraging range.

The so-called problems with our honeybee, such as excessive swarming and absconding are in a way inevitable and mainly due to local environmental shortcomings of the beekeepers. Therefore it is up to the beekeeper to help this honeybee to solve these problems, an inevitable course under such conditions.

The highest potential for honey production in Sri Lanka, lies in the Rubber growing areas which are under-utilized for the most part. Rubber plantations occupy about 10.5% of the total cultivated land area of Sri Lanka and 205,589 hectares are cultivated with Rubber. In comparison, in India 70% of her total production of 2.3 million kilograms of honey per year comes from the Rubber growing areas in the three states of Karnataka, Kerala and Tamil Nadu. As claimed by Indian authorities even this production comes only from a very small portion of the total Rubber area in India which is about 230,000 hectares.

From Table 10.5 it becomes clear that beekeeping need not be a full time occupation but can be a worthy side-line business for an enterprising person. Such persons can profitably utilize a valuable natural resource to increase the family income and nutrition that would have gone waste otherwise. Moreover, our honeybee is in perfect harmony with the natural environment of Sri Lanka and does not require any treatment against diseases, pests or predators. As we have seen earlier, it is a good defender and good producer.

Table 10.5: An Estimate of the Probable Time Required for an Operation Consisting of 10 hives.

Colony Condition and Required Management Practices	Time Needed Number of hours per week	Duration Number of months
Growth Period - Supplementary feeding - Transferring old brood combs to supers - Super building up and preparation - Increasing nest size	3 - 5 hours	5 - 6 months
Pre-Honey-flow Period - Colony dividing - New colony production	5 - 10 hours	1 month
Honey-flow Period - Honey extraction once a week	10 - 15 hours	1 - 2 months
Dearth Period - Reducing nest size - Preservation of old combs - Supplementary feeding	3 - 5 hours	4 - 5 months

This manual offers the prospects for managing this honeybee. Therefore, with the available technology, it qualifies to be an ideal candidate for a new, small scale viable industry.

Beekeeping technology, like any other technology, has to be learned by practising it. Though literature and other media may help to get a better knowledge about bees, these are essentially auxiliary. Anyone who is able and willing to work with bees can gain competency in managing honeybees profitably. Such enterprising persons should initially work with another beekeeper to gain the competency in handling bees. As such this manual is only a guideline. In the past as much as Vedda children learnt to gather honey by imitating their adults (see Front cover, inside) and played games on honey hunting, even today beginners will have to learn beekeeping by doing it practically.

***"One must learn by doing the thing,
for though you think you know it,
You have no certainty, until you try."***

**Sophocles (496 - 406 BC)
Trachinae**

"In personnel, natural aptitude has had little opportunity for development and with the present comparative absence of beekeeping practice will not be easy to obtain. In recruitment from the higher educated circles, there is the handicap of the very academic and theoretical setting with which higher education in Ceylon has been so closely bound, which has to be dealt with. In consequence of such education the development of practical ability has fallen far behind that of critical ability, resulting in a system of 'advising' which in effect is 'getting the other fellow to do it rather than do it yourself.' This is a well established characteristic of the mentality developed amongst the educationally privileged classes of a colonial country; but it is generally fatal to practical achievement and would be particularly so to beekeeping".

B.A. Baptist³,

**"Beekeeping with special reference to its development in Ceylon"
(22nd November, 1956)**

³Baptist, BA (1956) Beekeeping with special reference to its development in Ceylon, Presidential Address, on 1956 Nov. 22 (Quoted from page 115, paragraph 3) Agriculture and Forestry. 12th Annual Sessions, Ceylon Association for Advancement of Science, Part II, p. 99-118 Colombo.

A successful beekeeper will utilize a valuable natural and renewable resource such as nectar that would have gone waste otherwise. This will improve the family nutrition and income. At a national level it will contribute to alleviate rural under-employment and unemployment, and will form the base for new small-scale local enterprises. Further, beekeeping can form an integral component in conservation farming which is important be in perpetuating productivity in an agro-ecosystem and as such will be helpful in our own survival.

Therefore the following supportive activities will come into being, such as;

- 1** Manufacture of beekeeping appliances.
- 2** Production of colonies for sale to beekeepers.
- 3** Honey collection, processing, packing and marketing.
- 4** Bee-breeding and queen-rearing, which are more specialized activities in later stages (see Sections 10.6.3 & 10.6.4).

thus finally helping in national development.

One might add that beekeeping requires a friendly environment and also, in return, creates one.

10.6. The Future of Beekeeping: an epilogue

10.6.1. Crop Pollination Requirements

Even though **crop pollination**, **wax production** and **honey production** are all components in apiculture the last seems the most prominent and widely practiced technology. Wax production can be considered as a by-product of honey production. In Sri Lanka the attention given to the pollination requirement of crops had been very little or none and more over there had not been a significant necessity to consider this as an important aspect. So far, in agricultural planning, the highest emphasis was given for the production of Rice. Now, as we are reaching self-sufficiency in our Rice production the future agricultural planning will emphasise more on the production of other field crops, vegetables and fruits. Then the significance of crop pollination will surface as a component of yield and the indispensable nature of **Insect and Bee Pollination** will be realized. In such a situation beekeeping will not be confined to the rearing of Mee Bees for honey production but other honeybees such as Bambara Bees, Danduwel Bees, Kanawe Bees and other Bees such as Carpenter Bees and many species of other wild bees (see Table 10.6) will have to be utilized to bring about effective pollination. The scientists will have to design effective ways and means of rearing and managing the effective pollinator for each crop⁴.

The colourful, attractive and fragrant blossoms of higher plants have evolved to attract pollen dispersing animals. Bees are the most effective and efficient pollen dispersing animals for several reasons, such as their great abundance, their quick flying ability, their tendency to visit several flowers of the same species in succession and the consistency in visiting them (or flower fidelity); their need for large quantities of nectar and pollen and moreover their specialized bodily adaptations such as specialized hairs (see Figure 1.18) to trap and hold several thousands of pollen grains have made them unique in their service to nature. The value of bees for pollination of wild and crop plants are incalculable. Therefore, in Sri Lanka several hundred species of bees are doing a great service in maintaining our food supply and nature, which in effect is helpful in our own existence. Therefore bees should be given protection for the sake of our own survival.

As evidence for the importance of crop pollination the effective pollination of **Cardomon** flowers (*Elettaria cardamomum*: Zingiberaceae) is brought about by Bambara Bees, is a good example. Similarly **Passion fruit** (*Passiflora edulis*: Passifloraceae) has evolved in its native South America to be effectively pollinated by Carpenter bees (*Xylocopa* species). During the decade of 1970s when Passion fruit juice had a good market value, many growers who attempted to grow passion fruits commercially had problems in effective pollination.

⁴In many parts of the world several species of bees other than the hive honeybee and non-social bees are being utilized for effective pollination. In India **Kanawe** bee is used. Especially in the USA several species of non-social bees are being used commercially for crop pollination. Of these the **Alkali bee** (*Nomia melanderi*: Halictidae) which builds its nest by making burrows in fine salty sand and **Leaf cutter bee** (*Megachile rotundata*: Megachilidae) which builds its nest in the dried up pith of plants by lining it with cut pieces of leaves are the well-known examples.

Table 10.6: A Brief Mention of the Families of Bees Which Can Be Important for Crop Pollination.

Super Family Apoidea

- | | | |
|---|----------------------|---|
| 1 | Family Apidae | - Honeybees. Social bees who store honey and pollen in their nests. |
| 2 | Family Colletidae | - Plaster bees or Membrane bees. Many build their nests in the soil. The female bee line their brood cells with a liquid mixture of chemicals which harden to form a clear transparent membrane which is water proof. |
| 3 | Family Halictidae | - Sweat bees named because some of them are attracted by human sweat. Build their nest in soil and many of their nests are spread out in a particular location. |
| 4 | Family Andrenidae | - Digger bees. All species nest in the soil. Many species have their nest in dense aggregations. In some species two or more females use parts of a single nest like communal nest. |
| 5 | Family Megachilidae | - Leaf cutter bees. Many species are important pollinators of crop plants. Use cut pieces of leaves to line the nest. |
| 6 | Family Anthophoridae | - Carpenter bees. Carpenter bees drill into wood to build their nest. Some of the prominent members of this family are shown in Figure 10.2. |
| 7 | Family Melittidae | - Some species build their nest with mud. |

These four families are not found in the Indian Sub-continental region. They are;

- 8 - Family Stenotritidae
- 9 - Family Oxaeidae
- 10 - Family Ctenoplectridae
- 11 - Family Fideliidae

Therefore, the Passion fruit growers had to use humans to pollinate the flowers artificially with the use of painting brushes. The pollination requirements of many crops cultivated at present are being fulfilled by several species of bees and the importance of bees as a component of yield is already being realized in **Tala** or **Sesame** and in **Coconuts** (see Figure 10.1). The importance of bee pollination for proper seed set in **Sun flower** (*Helianthus annuus*: Compositae) which can be an important crop in the future is well-known.



Figure 10.1: A Mee Bee pollinating a Tala (Sesame) flower.

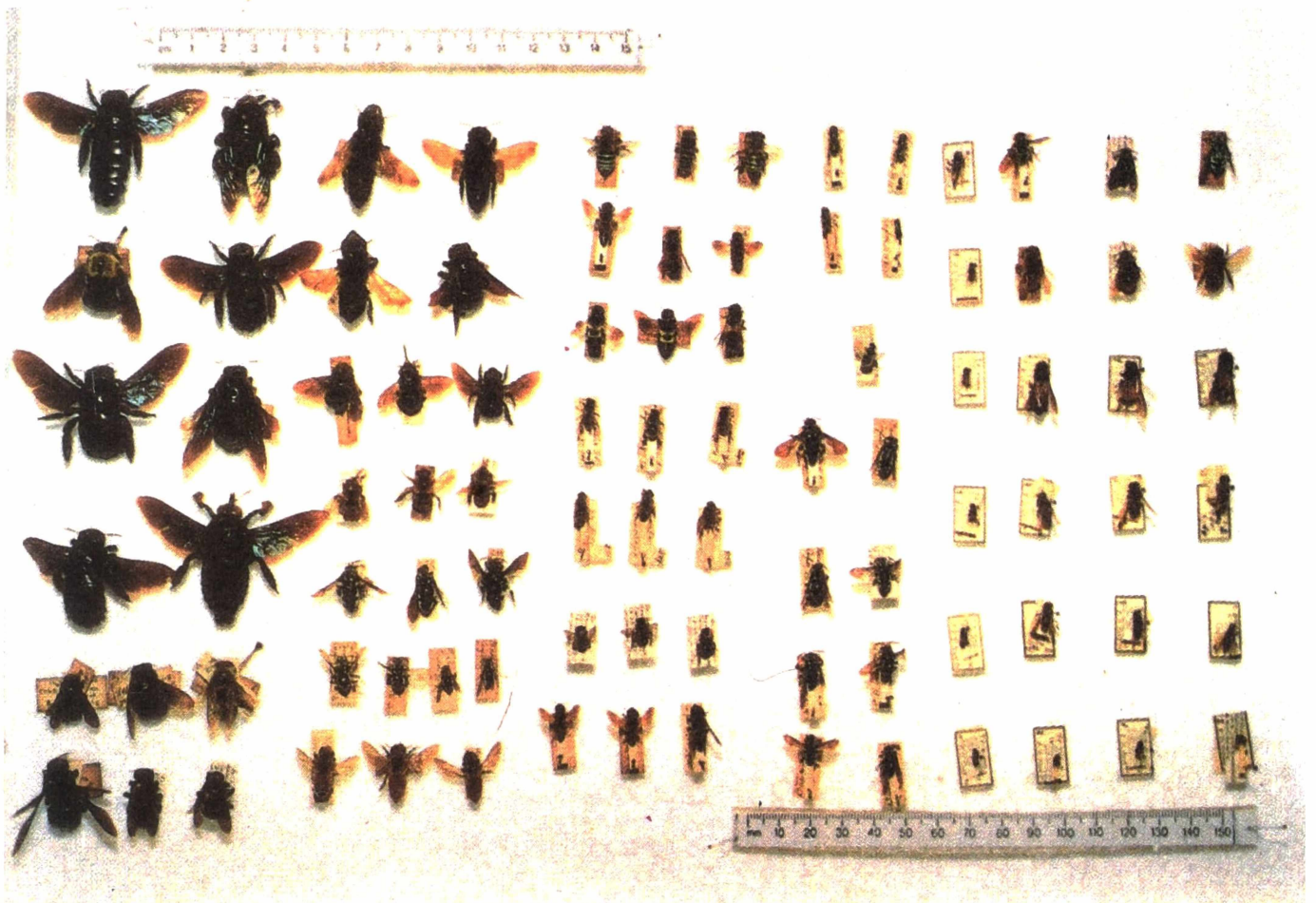

Figure 10.2: Some of the Native wild bees of Sri Lanka that can play an important role in crop pollination. On the left hand side are the large Carpenter bees (Family: *Anthophoridae*, Genus: *Xylolopa*). Note the great variation in size and coloration. (From the Bee Collection of the Entomology Division of the Sri Lanka National Museum).

The complex relationships and special adaptations developed both by bees and the flowers could easily be observed if one watches two common plants used in indigenous medicinal preparations, **Ath thora** (*Cassia alata*: Leguminosae) and **Wara** or **Ela wara** (*Calotropis gigantea*: Asclepiadaceae) where the Carpenter bees are well adapted for this purpose. Similarly many of us may have seen the Carpenter bees who visit to pollinate the showy, pendulous flowers of **Thunbergia** (*Thunbergia grandiflora*: Acanthaceae) an ornamental creeper in home gardens (see Figure 10.2).

The pollination requirements of **Gherkins** (*Cucumis anguria*: Cucurbitaceae) grown by the farmers in the Dry Zone of Sri Lanka for export, perhaps is one good occasion to demonstrate the importance of bee pollination. One of the major problem faced by the **Gherkin** farmer is the low quality fruit set caused by insufficient pollination and to remedy this many attempts had been made to rear Mee Bees in Gherkins fields with not too impressive results. Therefore, this problem should be tackled in a more systematic manner aimed at devising means for pollinator management as much as the application of cultural practices such as land preparation, fertilizer usage, irrigation, pest and disease management etc., For this purpose the initial step should be to identify the most effective pollinators and then to device ways of rearing them in the Gherkin fields. It is important that both farmers and exporters pay their due attention to this problem.

10.6.2. Factor Analysis of Honey Production

Even though the bees are an important component in nature conservation and in economic crop production the future of the beekeeping industry may rest on the economics of honey production. When analyzing the factors contributory to honey production as mentioned in Chapter 2 the following relationships become apparent. In the following account all the contributory factors are being examined and visualized to seek their significance in improving productivity in beekeeping for honey production. In this analysis the unit of production is considered as a single colony of honeybees.

$$\text{Honey Production} = \text{Population of Honeybees} + \text{Nectar Secreting Plant Community} + \text{Climate} \quad \text{---} \quad \boxed{1}$$

The effectiveness of a Population of Honeybee in honey production, in the above formula can be seen clearly by expanding it as follows,

$$\text{Population of Honeybees} = \text{The Size of the Population} + \text{The Flight Range of the Population} \quad \text{---} \quad \boxed{2}$$

The population size in equation $\boxed{2}$ can be further expanded as or it is dependent on,

$$\text{Population Size} = \text{Genetical Factors} + \text{Environmental Factors} \quad \text{---} \quad \boxed{3}$$

The Environmental Factors in equation **3** can be further expanded as,

$$\text{Environmental Factors} = \text{Natural Factor} + \text{Artificial Factors} \quad \text{---} \quad \mathbf{4}$$

The artificial factors in equation **4** can be visualized as the management procedures adopted by the beekeeper then,

$$\text{Environmental Factors} = \text{Natural Factors} + \text{Management} \quad \text{---} \quad \mathbf{5}$$

Climatic Factors in equation **1**, Environmental Factors in equation **3** The Natural Factor is equation **4** and **5** could all be grouped as **Natural Environmental Factors**. Then the equation **1** could be expanded as follows.

$$\begin{aligned} \text{Honey Production} &= \text{Genetical Factors} + \text{Management} + \text{Flight Range} \\ &+ \text{Nectar Secreting Plant Community} \\ &+ \text{Natural Environmental Factors} \end{aligned}$$

In this book a higher emphasis was given to the "**management**" or the artificial manipulation of a nest of honeybees. Other factors connected with management such as the flight range and prevention of undesirable effects of natural factors too were discussed to some extent. However, with regard to the **genetic improvement** in honeybees only a very brief mention was made in Section 6.3 (p.135) with a suggestion to up-grading of the stock with "colonies having superior features related to productivity". Nevertheless it should be remembered that the availability of honeybee strains or varieties with higher productive capacity is one of the most important factors directly related to increasing honey yields.

The genetic make up of the honeybee queen who is the only reproductive animal is most influential in determining the characteristics of a colony of honeybees. Therefore, our attempts should be directed at changing the characteristics that are desirable in our favour and to improve them further. Breeding and improvement of honeybees will help in increasing the income of the beekeepers as well as they may help in overall improvements of the agricultural productivity of a country.

10.6.3. The Need for and the Problems of Breeding Honeybees

Undoubtedly for the development of Agriculture it is essential to have improved varieties of seed and planting materials and improved strains of livestock breeds. These improved varieties of plants and animals responded well to various agronomic practices and animal husbandry methods and thereby gave higher yields. Therefore, in Beekeeping for honey production too such an approach needs to be adopted.

Unfortunately, so far there exist no improved variety of honeybees in the tropical Asiatic region. In this region what is utilized in beekeeping are the colonies captured from the wild but not any upgraded strains through breeding. The non-existence of a traditional beekeeping practice in this region may have been a contributory factor for this deficiency.

Western nations have reared bees from time immemorial and beekeeping has been one of their traditional industries. However, even with such a long tradition in beekeeping they have not been able to breed strains of bees that are comparable with the accomplishments in breeding other farm animals. Especially when one compares the achievements made by the Westerners⁵, Indians and Chinese⁶ in breeding farm animals all these nations seem to be at a fairly preliminary stage in relation to breeding bees.

As it is well-known, the most important factor in controlled breeding is the ability to control the mating or the reproductive activities of the parental animals. If the mating cycle of the parental animal could be controlled they could be selectively bred among animals who possess characters desirable from breeders' or farmers' point of view.

The first recorded effort to achieve control mating of honeybees were attempted by Réaumur of France by confining queens and drones together in a glass cage in 1740. In 1771 Anton Janscha of Austria described the mating process that take place outside the hive and the importance of the "mating sign" (see Figure 10.4, p.205). Dzierzon (1811-1906) of Germany, who is considered the father of practical beekeeping in Central Europe discovered that drones were produced from unfertilized eggs or by parthenogenesis. Huber (see p. 78) tried to inseminate queens artificially without success and Watson in 1926 (see p. 79, Table 4.1) made the first successful demonstration in artificial insemination in honeybees.

Unfortunately, unlike with the other domesticated animals in the case of honeybees the reproductive or the mating process cannot be artificially guided or controlled. As reasons for this inability the following phenomena connected with the natural mating behaviour of the honeybees could be given:

- 1 Honeybees who live as social colonies cannot mate, reproduce or live as an isolated pair unlike non-social insects. For an example the silk worm, another domesticated insect, has been bred for centuries to suit Man's needs. This phenomenon could easily be understood by contemplating the life cycle of butterflies.
- 2 A honeybee colony consist of a single fertile female or the queen and her daughters. Both these two castes are important for the productivity of the colony. However, the genetic characters of these two types of individuals are not identical. Therefore, one individual can not be taken as the unit of selection but the whole colony. When a colony with superior characteristics are found, to propagate this, the virgin queens and drones from this particular colony have to be selected. Then the selection has to be based on the performance of the 3rd generation or the grand daughters of the original queen. As such the desirable characters of the original queen may have been changed significantly in the 3rd generation.

⁵Due to long term selective breeding and improvement of Cattle, Goats, Poultry, etc., Westerners and Indians have inherited farm animals with improved productive potentials.

⁶The Chinese, along with other farm animals have bred and improved strains of Silk Moth (*Bombyx mori*: Lepidoptera) for the commercial production of Silk for thousands of years.

- 3** The peculiar nature of the sex determination process in honeybees has imposed another difficulty in breeding among closely related individuals unlike with other domesticated or farm animals. When closely related individuals are bred a phenomenon called "homozygous sex allele combination" can take place and this is lethal to the offspring in the case of honeybees.

The Phenomenon of Lethal Homozygous Sex Allele Combination in Honeybees

In bees as well as in other members of Hymenoptera, a fertilized egg will give rise to a female individual and an unfertilized egg produces a male individual. Therefore, female animals possess a Diploid genetic make up and male animals possess a Haploid genetic makeup. In other words a female animal has a gene combination received from both mother and father (diploid) and a male animal receives his genes only from the mother (haploid).

The following brief analysis will help us to understand the genetic or gene manipulation that leads to the "lethal homozygous sex allele combination" in the offspring. The offspring inherit their characteristics from parents through a group of molecules named as **genes**. There are specific genes concerning each particular character. These genes could be considered as a basic factor in carrying the characteristics of the parents to the offspring. Therefore, a gene is the unit of inheritance that is transmitted in a **gamete** (a mature reproductive or germ cell, in male it is the **sperm** and in female it is the **ovum**) and controls the development of characteristic by **interaction with the other genes**, the **cytoplasm** (part of the cell outside the nucleus, genes are contained in the nucleus) and the **environment**. As there can be alternative forms of a characteristic (coming from both parents) these alternative forms of a gene is called **alleles**.⁷ In many cases more than two alternative forms affect the same characteristic and these are called multiple alleles.

The alleles concerning a single characteristic can be dominant or recessive or intermediate. Where a single gene concerned, when two different alleles are together such a combination is called a **Heterozygous** state. The expression of the characteristics concerning a gene depends on the expression of the dominant allele. When two alleles of the same type exist in a gene location then such a state is called **Homozygous** state. For an example, the existence of several alleles becomes clear when one looks at the fur colour of cats and dogs which has a very high variability.

⁷The nucleus of a cell contains some structures called **chromosomes**. These chromosomes contain the genes that transmit characters from one generation to another. The chromosomes are capable of self duplication through successive cell generations. The number of chromosomes contained in the cell nucleus is a constant number for each particular animal (or plant) species. For an example the **somatic cells** (the body cells or the cells other than reproductive cells such as sperms and ova) of honeybee has 32 chromosomes the reproductive or gamete cells (sperms and ova) contain half this number or 16 chromosomes. In the case of Drones even their body or somatic cells also contain only 16 chromosomes or half the number of chromosomes in the worker and the queen honeybees. Therefore, the Drones are identified as haploid animals and female individuals as diploid. It has been calculated that the sex determining gene in honeybees has 16 to 17 alternatives or 16 to 17 sex alleles. The sex genes are conventionally named as the X gene. Therefore, these alleles could be further named as X_a, X_b, X_c..... upto X_p or X_q using the letter of the English alphabetical order.

When we consider the sex determination in honeybees, the sex gene is called X and various alternative forms of the alleles could be marked as X_a , X_b , X_c ... etc., Therefore, in the formation of fertilized egg where both the ova and sperm combines, there can be two forms of alleles such as X_aX_b or X_aX_c or X_aX_d or X_cX_betc., or it can be considered to have diploidy at the sex determination gene locus or gene site. The drone, that is produced from an unfertilized ovum has only a single allele at the sex determination gene locus or can be considered as haploidy. The genetic manipulation in honeybees in sex determination is briefly illustrated in Table 10.7. It becomes clear from Table 10.7 that the productivity or condition of a colony of honeybees has to be estimated by the combined performances of the individuals of two generations, i.e. egg laying queen (parental generation) and the worker bees (offspring or filial generation).

Further it also becomes clear that if in-breeding takes place between siblings or fertile sisters (virgin queens) and brothers (drones) of the same colony 25% of their offspring is bound to die due to lethal inbreeding⁸ when considering the average of all possible combinations (see Table 10.7).

- 4 The reproductives (drones and virgin queens) mate or copulate outside their nest and while in flight (see Figure 10.3). This phenomenon is completely beyond the beekeepers control and all attempts to mate queens in enclosed spaces have failed. Therefore, it imposes an additional difficulty in bringing about controlled mating similar to the other domesticated animals.

However, due to the long tradition in Bee Culture among Western nations it has given rise to the selection of high productive strains based on certain geographical regions. The **Golden Italian Bees** and the **Black German Bees** are two well-known examples of honeybee stocks with good productivity in Europe. The **Buckfast Bees** in England is another productive strain due to the out come of a selective breeding programme that operated for a few decades in the recent past. The artificial insemination technique for honeybees invented in 1926 (see Table 4.1) which is still being improved and refined can be a powerful breeding tool in the near future. However such techniques have to be further perfected and refined to suit our honeybee, *A. cerana* who has distinctly different morphological characters especially with regard to the reproductive organs and the quantities of sperms are much lower than that of *A. mellifera*.

⁸Homozygous sex alleles give rise to diploid drones. Diploid Drones are non-viable under natural circumstances and they could only be reared under artificial conditions with special attention. The sex determination process is briefly outlined below.

Allele Composition of the Sex Gene	The Resulting Nature of Individual	Survival
Heterozygous Diploid (X_aX_b)	Female (2n)	Viable
Homozygous Diploid (X_aX_a)	Male (2n)	Non-viable
Haploid (X_a)	Male (n)	Viable

Table 10.7: The Genetic Manipulation of Honeybees in Sex Determination and in the Production of Homozygous Offspring When Three Sex Allels (X_a , X_b & X_c) are Taken as an Example.

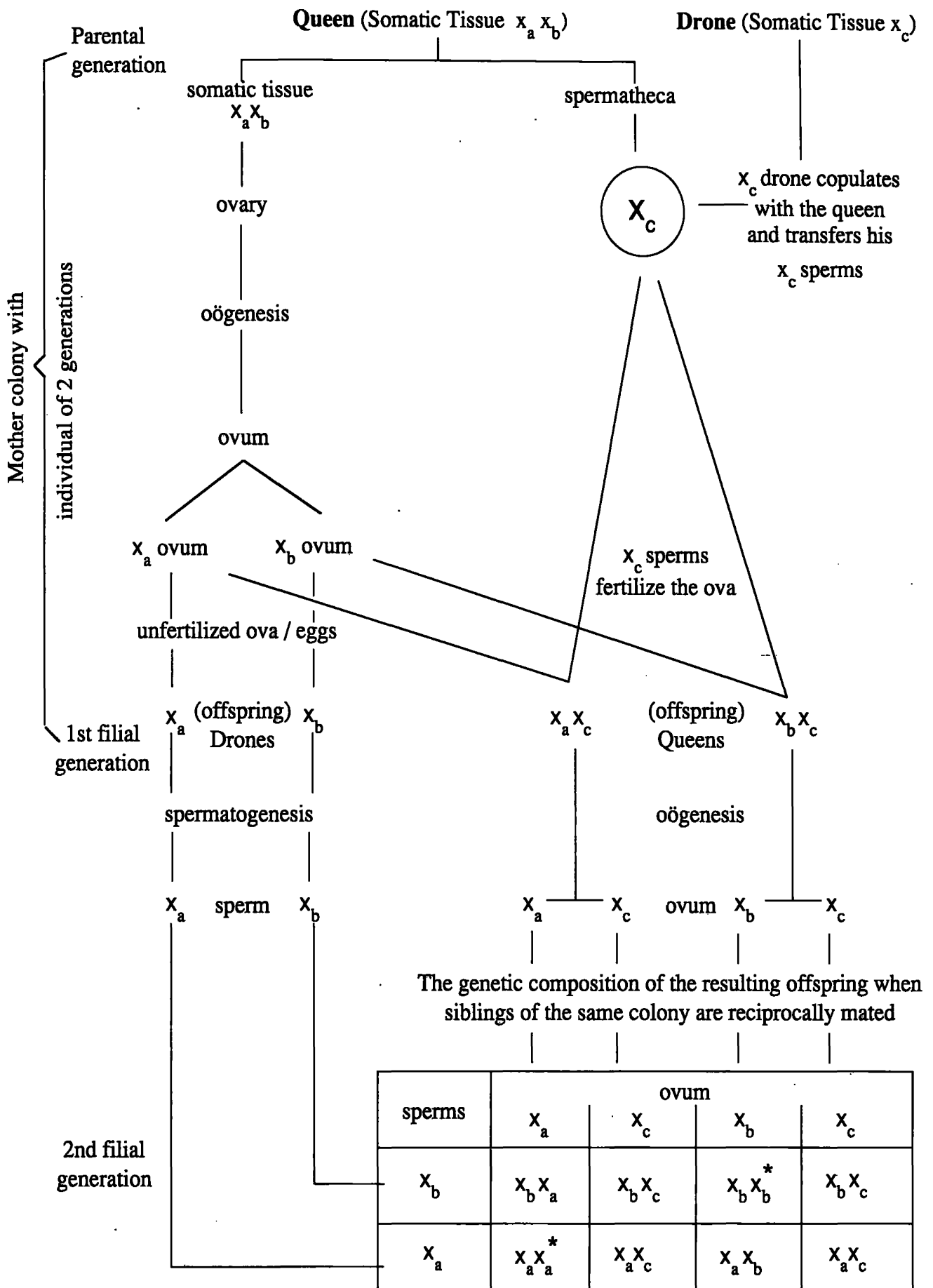

* 25% of the individuals are Non-viable or homozygous in the 2nd filial generation.

10.6.4. Action Plan for the Improvement of the Indigenous Mee Bee or the Local Hive Honeybee

According to the recent findings based on the observation of the natural mating behaviour of the indigenous Mee Bee such as the drone flight period, drone congregation area formation, drone flight range, flight period and duration of the virgin queen, etc.; there are strong evidences to suggest that the mating process could be controlled artificially to some extent. It was found that our Mee Bee forms its DCA at a very close distance from its nest or hive (often within 200 metres and very frequently within 100 metres). The drones who fly at the DCA expecting the arrival of a mate seeking young queen do so in a free space among the canopies of trees which offer them the natural protection from predatory birds. Figure 10.3 shows a typical DCA of *A. cerana* drones in Sri Lanka. Therefore, the drones of the colonies selected for breeding can be arranged in such a way, that they fly in a DCA naturally selected by them in the close vicinity. Then obviously the mate seeking queens too would use this DCA in the close vicinity for successful mating⁹.

Therefore, the supplementary feeding could be done in such a way as to maintain a large number of colonies within a relatively small area (see Table 7.1) so that the drones and the virgin queens will fly in to DCAs in the close vicinity from their hives. An other advantage of keeping a large number of colonies close to each other through supplementary feeding is that, such an apiary can comprise all the necessary sex alleles (X_a , X_b , X_c ... upto X_q) to prevent lethal inbreeding or keeping this potential set back at a minimum level. The Figure 10.4 shows a successfully mated queen soon after returning to her hive with the **mating sign** in a controlled breeding experiment. Therefore, what is more appropriate for Sri Lanka in improving the productivity of the indigenous Mee Bee is to interfere with her natural mating behaviour skillfully and ingeniously, to turn it to our advantage as previously stated. This process could be called a "**Controlled Natural Breeding Method**" which may be more practical and relatively easy under our conditions.

Here, one of the major problems will be to find (or select) the foundation stock to be used as the original parents of the breeding stock. For this selection it is imperative to estimate the productivity of each colony that is intended to be the foundation stock. Then it becomes necessary to evaluate the productivity and other characteristics related to productivity.

⁹Punchihewa, RWK (1992) Mating behaviour of *Apis cerana* in Sri Lanka is advantageous for controlled natural breeding. *Apidologie* 23: 348-349.

Punchihewa, RWK; Koeniger, N & Koeniger, G (1990 a) Congregation of *Apis cerana indica* Fabricius 1798 drones in the canopy of trees in Sri Lanka. *Apidologie* 21:201-208.

Punchihewa, RWK; Koeniger, N & Koeniger, G (1990 b) Mating behaviour of *Apis cerana* in Sri Lanka. p 108 "In Veeresh" GK; Mallik, B & Viraktamath, CA (Eds) *Social Insects and the Environment* xxxi + 765 pp' ISBN 81-204-0532-3, Oxford & IBH Publishing Co. Ltd. New Delhi 11001, India.

Therefore at the beginning, honeybee breeding methods have to be tested out under more controlled conditions such as in Agricultural Research Institutes and once the techniques are perfected the technology could be adopted and practiced with ease by the beekeepers. Already our attempts have been pursued along these directions and with time the beekeepers will be able to obtain thorough-bred-bees with improved productive potentials.

It has been commonly asked whether it is possible to use already improved Western honeybee (*Apis mellifera*) strains to hybridize and improve the local bee? Biologically two distinct species of animals can not mate successfully and produce a viable offspring. Even though, *A. mellifera* and *A. cerana* are two closely related species of hive honeybees their genetic makeup is such that they are unable to mate and reproduce successfully. Further the morphological characters of the reproductive organs of these two species of hive honeybees too are incompatible reciprocally.

Moreover when these two species were artificially inseminated reciprocally by overcoming all the existing difficulties for successful mating, the resulting zygotes (fertilized ovum) die out before they reach the embryonic stage. There has been no success in crossing to produce *A. mellifera* X *A. cerana* larva due to genetic incompatibilities. Therefore, there exist several anatomical, morphological and cytological incompatibilities in preventing the production of a hybrid *mellifera* X *cerana* honeybee.

Then we are left to find an alternative way to improve the productivity of our hive honeybee, *A. cerana*, in her own environment.

It is a point of interest to note that now several South-East Asian Nations including Sri Lanka have embarked on a joint effort to improve the native *A. cerana* through a cooperative breeding and improvement programme.

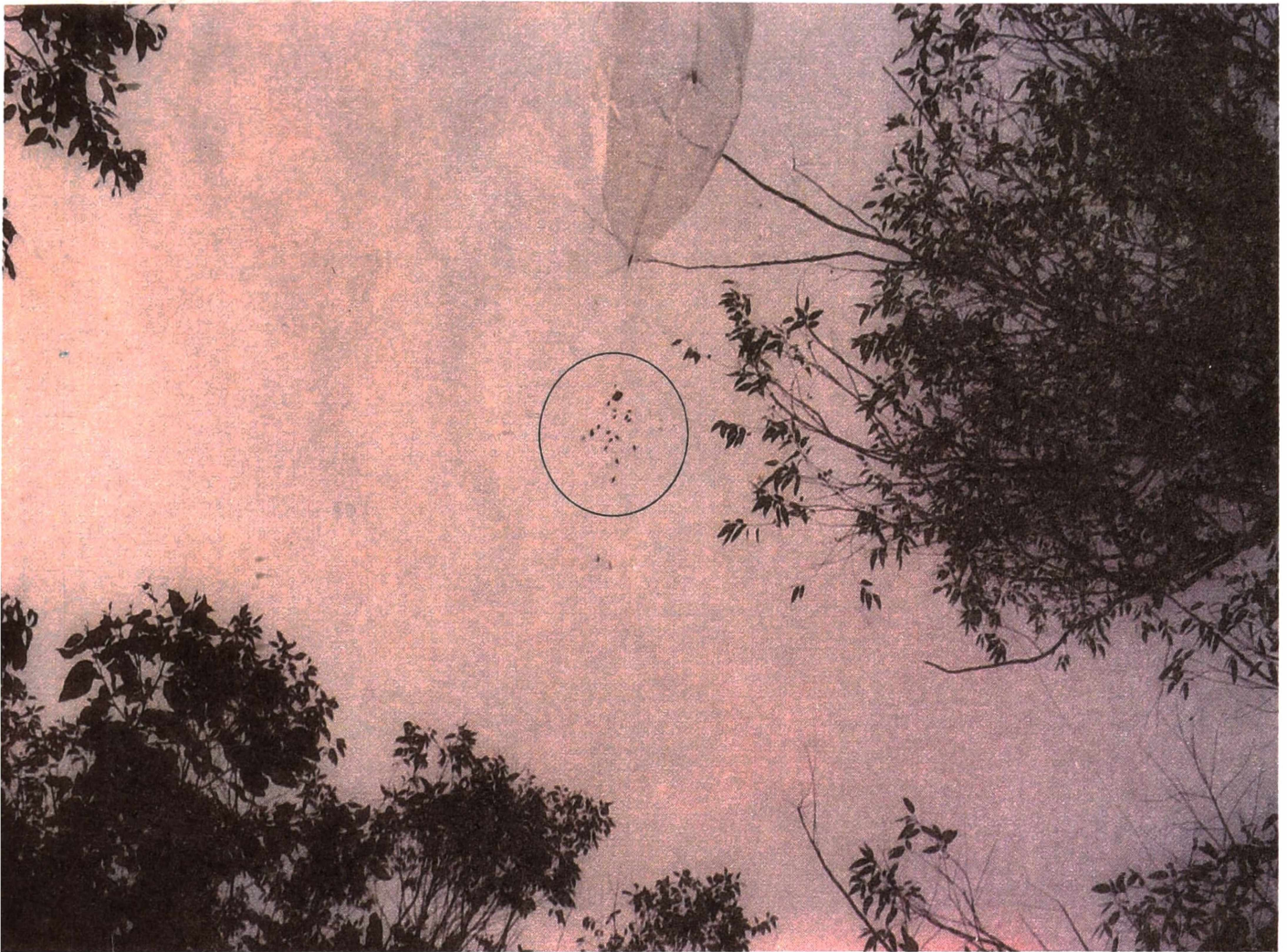

Figure 10.3: Controlled Natural Breeding Experiments 1: A Drone Congregation Area (DCA). The demonstration of a DCA of the Indigenous honeybee among the canopies of trees by providing a caged queen to the DCA with the use of a Hydrogen balloon. The drone congregation around the queen is shown by the circle. A caged queen can not mate at all and here a queen is floated in the DCA to demonstrate its existence and to study its characteristics. In such experiments it is not necessary to use a live queen but it is possible to use a small piece of wood (5 x 5 x 10mm) impregnated with queen substance (1mg of 9-ODA dissolved in Alcohol) as a dummy queen.

The drones get attracted to any flying object traversing through DCA and in fact the flying drones get attracted even to a small stone thrown at the DCA or to other insects flying across it such as Hornets, Dragon flies, Butterflies etc. However, to form a stabilised congregation or a so-called comet of drones such as shown in the picture it is essential to use a live queen or the queen substance or the queen pheromone.



Figure 10.4: Controlled Natural Breeding Experiments 2: A young queen soon after returning from her mating flight in her mating colony with the "Mating Sign" intact. The mating sign or the mucus plug deposited by the last drone to mate with her will be removed by the workers in a little while after her return.

Under the above circumstances a possible way of improving the indigenous Mee Bee could be viewed to follows:

- 1** Selection of naturally existing colonies by estimating their productivity (**Selection of Strains**). Presently this takes place as all colonies are collected from the wild.
- 2** The search for an identification of morphological characters that are related to productivity and their utilization later for selection of strains can help to reduce the time taken for the selection of productive strains. (**Use of morphological characters related to productivity in breeding**).
- 3** To setup and develop a breeding gene pool by collecting high producing strains (**Breeding Gene Pool**).
- 4** To maintain a sufficient number of colonies from different sources in the breeding gene pool so as to prevent lethal in-breeding (**Prevention of In-breeding**).
- 5** Periodical introduction of new strains to the breeding gene pool (**Introduction of New Strains**).
- 6** The production of hybrid strains of bees with a better productive potential with the use of presently available knowledge on the mating behaviour of the indigenous honeybee to manipulate the Drone Congregation Area (DCA) formation and there by directing a controlled natural mating process (**manipulation of the DCA for Hybrid Strain Production or the use of Controlled Natural Breeding Method**)⁹.

Therefore our efforts should be made in these directions. It is clear from the above account that the beekeeper existing all over the Island can contribute immensely to build a breeding gene pool of better productive strains of Mee Bees. Better productive strains could be identified by the use of improved management methods (many of which are discussed in this manual), by evaluating the response given by bees to these management methods and by keeping records of their productivity.

As such breeding of improved Mee Bees have to be a collective effort both by beekeepers and scientists where they have to depend on the naturally existing Mee Bee colonies and the other related natural resources.

10.7. The Natural Resources We Inherit for the Development of Apiculture

Even though historically we do not seem to possess a tradition of Bee-culture, Honey had been an important and a common ingredient in our traditional medical practice. Attempted honey production may not have been a necessity due to the existence of large areas of forest, which supplied sufficient quantities of this commodity. Even at present honey hunting still takes place near forested areas.

It could be judged from the amounts of honey that comes from the forest through honey hunting that we possess suitable strains of honeybees in them that could be used for breeding high quality bees for the development of the honey production industry.

These forests also have not only a productive strain of Mee Bees but a large resource of other types of bees that could be used in crop pollination. Therefore, our forests contain an invaluable resource and a reserve of bee fauna that can contribute to honey production and crop production. As such we have to protect and preserve the forests, the natural birth place of all our bee fauna for the posterity and prosperity.

The Rubber growing region and the Red Gum growing region have to be utilized optimally for the commercial production of honey. One good example to demonstrate the potential that exists in the Red Gum region is the migration of Bambara Bee colonies to this region during the flowering of these trees. Therefore, our attempts should be directed at increasing the per colony yield in the Red Gum region and to popularize honey production in Rubber growing regions. Both these attempts will help to utilize a natural resource at an optimum level. Figure 10.5 illustrate the distribution of natural resources available to us for the development of Apiculture.

Figure 10.5: The Natural Resources in Sri Lanka for the Development of Apiculture and the Major Climatic Zones

- The Rubber growing and Red Gum growing areas have a good potential for honey production.
 - The forest contains a valuable genetic resource that could be used for the improvement of the local hive honeybee or the Mee Bee.
 - In these forests there exist many other species of bees that could be used in crop pollination.
 - The honey hunting that takes place in the forests and in near by semi-forested areas still render a great service by providing the bulk in the local honey supply.
-

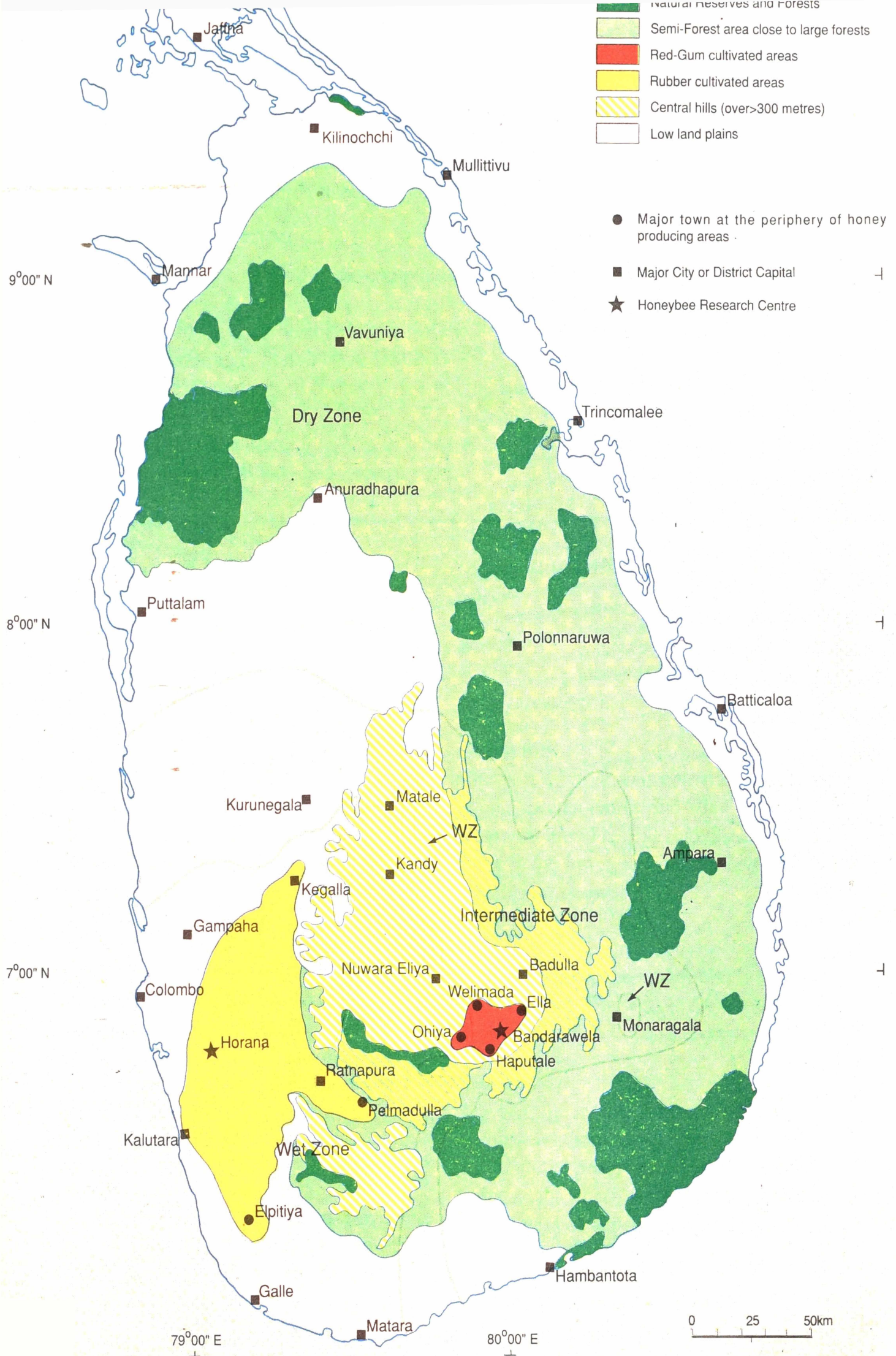

11. GLOSSARY

The objective of this glossary is to help the non biological reader to understand the meanings of some of the specific words used in relation to honeybees that may not sufficiently be explained in the text.

The following books were used in the compilation of the glossary.

Michener, CD (1974) *The Social Behaviour of the Bees*, xxi + 404 pp. Harvard University Press, Cambridge, Mass., USA. (ISBN 0 - 674 - 81175 - 5)

Steen, EB (1971) *Dictionary of Biology*, vii + 630pp. Harper & Row Publishers, New York, London, etc. (ISBN 0 - 06 - 463321 - 7)

Wilson, EO (1971) *The Insect Societies*, x + 548 pp. Harvard University Press, Cambridge, Mass., USA. (ISBN 0 - 674 - 45495 - 2)

Absconding

Departure of a whole colony of honeybees from existing nest site for a new nest site.

Altruism/ Altruistic

Self destructive behaviour performed for the benefit of the others.

Apiary

A place where honey bees are kept, especially a collection of hives maintained for honey production.

Bee / Bees

Insects constituting what is usually called the superfamily Apidea. A group of insects primarily evolved to derive its nourishment from flowers. A sterile female who does all work required by the colony for its sustenance other than the reproductive functions. Usually called a worker. (see also Honeybee)

Bee Milk

Larval food of honeybees, secreted by nurse bees and probably mixed with some crop

(honey stomach) contents. (see also Royal Jelly)

Brood

A collective term for immature stages, viz. eggs, larvae & pupae.

Brood Box

The part of hive that contain all the brood combs, pollen stores and some honey stores where all brood rearing activities takes place. Usually the lower section of a hive assembly. (see Honey Supers)

Cell

A prepared space in which a single immature bee is reared. The worker and drone cells are hexagonal, while the queen cell is circular.

Colony

The mature female bees working in a nest with the immature stages being actively cared for, usually progressively fed. A group of individuals which construct nests and rears offspring in a cooperative manner.

Comb

A construct made by bees with wax they secrete and composed of two layer of regularly arranged hexagonal cells connected from their bottoms and sides. Comb construction takes place vertically downwards (towards gravity). (see also Nest)

Communication

Action on part of one member of a colony that alters the behaviour of another member of the colony. Sending of signals that influence the behaviour or development of others usually in the same colony. (see Dance, Pheromone)

Dance

A specific types of body movements in honeybee (Genus *Apis*) to communicate the location of food sources and new nest sites to the other colony members. Body movements of communicative importance usually performed on the combs of honeybees crowded with other nest mates.

Dividing

Multiplication of colonies by separating the old queen with a few brood combs and allow the queenless part to produce a new queen.

Division of Labour

Differing activities of the members of a colony. (see Polytheism and Polymorphism)

Drone

A male honeybee. (see Worker)

Feedback Mechanism

When the output of a system determines the input, especially to modify or control the input. A controlling mechanism in an organism by which functional activity is regulated through factors which are returned or fed back to the controlling centre with resultant inactivation (depression) or activation (stimulation).

Floor Board

The bottom most part of the hive assembly. The component on which the rest of the hive rested upon.

Foraging Range

The distance from the hive within which the worker bees are able to gather the food.

Hive

A man made container in which a colony of bees live.

Honey

Nectar that had been collected by the bees and partly digested, that is the sweets are broken down to simple sugars (mostly Glucose & Fructose) and from which a part of water has been evaporated.

Honey-flow

The time period which one or several species of plants in an area secrete nectar at a level which is over and above the normal maintenance, growth and reproductive requirements of honeybee colonies in the vicinity. Therefore this nectar will get collected (stored) in honeybee colonies as Honey. The time period which the honey is available in honeybee colonies for harvesting.

Honeybee

A bee of genus *Apis*. In this manual *Apis cerana indica* worker.

Honey Suppers

The part of hive that contains the honey stores for the extractions by the beekeeper. The honey suppers are usually kept on top of brood box. The section of the hive that contains honey for harvesting.

Inactive Ovary

The ovary that does not produce ova or eggs. The ovaries of the worker bees are reduced in

size and inactive. The queen substance prevent the development of ovaries in workers.

Inquiline

An organism that hives within the nest or abode of another, as insects that live in the nest of termites, ants and bees.

Inquilinism

The relation in which a socially parasitic species spends the entire life cycle in the nest of its host species.

Insectivore

Any insect eating plant or animal.

Insects

Any member of the animal class Insecta (Hexapoda), air breathing arthropods with a body of three parts. (head, thorax and abdomen), three pairs of legs, usually two pairs of wings. Head bear one pair of antennae and a pair of compound eyes. Comprise the most numerous group of animals with nearly 800,000 described species.

Larva

The worm-like wingless, immature, feeding form which hatches from the egg in insects which undergo complete metamorphosis. Larvae (pl.)

Laying Worker

A worker that develops her ovaries in the absence of a queen or queen substance and start to lay eggs. Laying worker colonies could be easily recognized due to multiple eggs in a cell.

Metamorphosis

A change in shape or form which an animal undergoes in its development from egg to adult as seen in insects. (Example: Egg, Larva, Pupa, Adult such as in the case of

Bees who under go a complete metamorphosis or Egg, Nymph, Adult such as in the case of Cockroaches who undergo an incomplete metamorphosis).

Migratory Beekeeping

The management of bees for the exploitation of several honey-flows that take place in different locations at different time periods. The honeybee colonies are moved into an area of nectar secreting plants so as to have such plant communities within the average foraging range of the honeybees.

Nectar

The sweet fluid secreted by the nectaries of plants, commonly in flowers and in the case of Rubber the major nectaries are situated on the petioles of the leaflets.

Nest

A construct made by the bees in which the young are reared, adult live with their food stores.

Nest Site

The location of the honeybees nest. In the case of *Apis cerana* it is usually naturally protected hollow dark space, such as in a hollow tree trunk, a rock crevice. Often people provide nest sites by keeping a hollow log or a clay pot in a tree in the home garden to invite a swarm of nest site seeking honeybees.

Nurse Bee

A worker bee that feeds and cares for larvae.

Orphan Colony

A colony that has lost its queen or when the existing queen is unable to functional normally.

Ovary

The organ which produces ova or eggs.

Parasite

An organism which lives in or on another organism from which it derives its nourishment.

Pheromone

A chemical substance in small quantities of which serve for chemical communication among individuals in a colony. In principal it is a chemical secreted by one individual that affect the behaviour and or physiology of another of the same species. (see Queen Substance)

Phoresis

A form of symbiosis in which the host transport the symbiont.

Polarized light

A type of light waves in which the direction of vibration lies in a single plane. The light comes from blue sky is partly polarized, with both the direction of vibrations and the intensity of polarization depends on the position of the sun. Honeybees are sensitive to polarized light and therefore they are able to determine the position of the sun without seeing it. Humans are unable to see polarized light.

Pollination

The transfer of pollen from an anther to a stigma of a flower, accomplished by the wind, water, insects, birds, bats or artificially.

Polyethism

Division of labour among members of a colony. In social insects a distinction can be made between caste polyethism in which morphologically different individuals (eg. honeybee queen and workers) or castes are specialized to serve different functions and age polyethism in which same individual passes through different forms of specialization as it grows older such as

different functions of the honeybee worker depending on its age. (see Polymorphism)

Polymorphism

Coexistence of two or more functionally different castes within the same sex such as honeybee queen and workers. Functionally queen is responsible for reproductive functions and workers are responsible for all other functions other than reproduction.

Predator

Living by killing and eating other animals. The one which capture and kill other animals for food.

Pupa

In insects with complete metamorphosis, a dormant inactive stage between the larva and the adult. Pupae (pl.)

Queen

The reproductive female in a colony that is primarily active in egg laying and totally inactive in foraging.

Queen Cage

A special wire cage where queen could be confined when necessary.

Queen Cell

The specially constructed cell usually at the edges of brood combs which are larger than the worker cells to raise new queens. (see also Supersedure Queen Cell)

Queen Court

A group of workers that form a circle around a queen of a honeybee colony, ordinarily antennating and licking her and sometimes feeding her.

Queen Rearing

Procedure adopted in making new queen to replace the older ones.

Queen Right

Referring to a honeybee colony that contains a functional queen.

Queen Substance

The inhibitory pheromone secreted by queen honeybee that prevent construction of queen cells by workers and enlargement of the ovaries of workers. Originally, the set of pheromones of which the queen honeybee continuously attracts and controls the reproductive activities of the workers. But now normally used to designate 9-oxy-2-decenoic acid (9-ODA), the most potent component of the pheromone mixture. (see Pheromone)

Re-queening

Replacement of the existing old queen with a young queen. Usually done just before or at the commencement of the honey-flow.

Royal Jelly

Bee milk deposited in queen cells. Secretions from the mandibular glands of workers that serve as food for the developing queen larvae. Usually the young workers who are called nurse bees secrete more of this to feed young larvae up to the age of 3 days.

Social Homeostasis

The maintenance of steady state at the level of the society either by control of the nest micro-climate or by the regulation of the population density, behaviour and physiology of the group members as a whole.

Somatic

Pertaining to the body cells in contrast to reproductive cells.

Spermatheca

The reservoir in the queen in which sperm cells are stored after mating and from which they are released to fertilize eggs.

Super Organism

Any society, such as the colony of honeybees possessing features of organization analogous to the physiological properties of a single organism. Honeybee colony, for example, is divided in to reproductive castes (analogous to gonads) and worker castes (analogous to somatic tissue).

Supersedure

The production of a new queen to replace an aging one, still present in the colony.

Supersedure Queen Cells

Queen cells constructed under the supersedure impulse (when the functional queen is lost or become invalid due to an injury caused to her). They are generally constructed on the comb face (or surface), as opposed to normal queen cells at the edges of combs, under the swarming impulse.

Supplementary Feed

The food supplied by the beekeeper in excess of what is naturally available to the bees from the plants in the foraging range.

Swarm

A queen and workers that establish a new colony of honeybees.

Swarm (primary)

The first swarm sent out from an existing colony which is headed by the old queen. That is, the existing queen leaving the nest with a group of workers allowing a daughter to take over the reproductive functions. Usually this happen any time between queen larva development and virgin queen emergence.

Swarm (secondary)

One of the new queens may also leave the nest with a group of workers. Generally considered detrimental for honey production

as this would lead to progressive reduction of colony strength.

Swarming

Natural multiplication process of honeybees. Usually take place before the honey-flow season or during a period of food abundance. Queen and a large number of workers depart from the parental nest and fly to some exposed site. There they cluster while scout bees fly in search of a suitable new nest site. (a cavity)

Swarming Season

The time period at which the honeybee colonies will naturally reproduce. Usually take place before the honey-flow season or during a period of food abundance.

Symbiont

Either of two organisms living together in symbiosis.

Symbiosis

A mode of life in which two organisms of different species live in intimate association

with each other depending on the the nature of association. This relationship can be named as mutualism, parasitism, phoresis or inquilinism.

Top-bar

Specially prepared strip of wood for the honeybees to built combs, which is made in such away to give the required bee space between parallel combs and with an arrangement to get the bees to build combs straight.

Wax

Secretions from the eight wax glands situated in the abdominal sternites which they use to construct combs.

Worker

An sterile female bee who does all the functions for the sustenance of the colony other than reproduction. (see Bee)

Xenobiotics

A compound foreign or strange to life, such as agricultural pesticides.

12. REFERENCES

Today no book is considered complete without a list of references that were used in making it. However such a long list of references to fulfill that conventional requirement may serve very little purpose here for the beekeepers. The few occasion where a reference is made here are to some of the work carried out in Sri Lanka and to some of the classical reference material available on the topics discussed in the text. It was nothing but compelling to mention. These are referred as headnotes or footnotes in the relevant places in the text pages itself.

Among all species of animals, honeybees are the most widely studied species. Many countries have their own journals on beekeeping. For the preparations of this book in a broader sense the following publications were used:

- **Bee World, Journal of Apicultural Research and Apicultural Abstracts** (International Bee Research Association or IBRA, Cardiff, UK).
- **Apidologie** (Elsevier Science Publishing New York & Paris).
- **American Bee Journal** (Dadant & Sons, Inc., Illionis).
- **Gleanings in Bee Culture** (Al Root Co., Publishers, Ohio).

These perhaps may be the most comprehensive and up-to-date of all publication in English.

With regard to the management of Sri Lanka's honeybee, *Apis cerana indica*, only a handful of references are available and even these are, in one way or the other, based on the literature available on the western honeybee *Apis mellifera*. Even then, its usefulness for beekeeping with *Apis cerana* is rather questionable or very limited. For an instance according to the information recorded at the IBRA in 1992 & 1993 there has been 1508 and 1419 research and other reports pertaining to apiculture were published throughout the world respectively. Among these large number of publications in 1992 there were only 43 and in 1993 only 50 reports relevant to the Asiatic honeybee *Apis cerana*. Even from this relative small number, the information contained in relation to its use for beekeeping direct was rather scarce. Therefore many of the management procedures discussed in this book are based on already concluded on on-going experiments conducted currently.

To enlighten the reader on the historical facts about the development of beekeeping in Sri Lanka some writing of the pioneers are given in the pages to follow. Special mention may be made of a pioneer piece of writing on beekeeping published in Sri Lanka authored by Mudaliyar Samuel Jayatillake and published in the Royal Asiatic Society Journal in 1881 (see Appendix 12.1). Mudaliyar Jayatillake in 19th century was also the first known beekeeper in Sri Lanka (Ceylon) who, on his own statement, took to beekeeping, having seen the wasteful methods adopted in honey hunting. Attention may be also focused on the 287 paged book published in Singhala language authored by Mr. AP Goonatillake (1916) in his indefatigable attempt to popularize the new industry of beekeeping in Sri Lanka (see Figure 12.1). In Appendix 12.2 is the preface written by another pioneer, Mr. C Driberg for Mr. Goonatillake's book which clearly summarises the events which took place during the first half a century of Beekeeping in Sri Lanka (then Ceylon).

CEYLON BEE CULTURE.

BY SAMUEL JAYATILAKA, MUDALIYAR.

(Read April 7th, 1881.)

I have been interested in the culture of the honey bee of Ceylon for about the last 25 years, from accidentally observing at first the mode of bee-keeping by bee-hunters and others in the Wanui, a remote part of this district (North-Western Province.) I set myself to work at once in trying to improve the system. By the courtesy of Mr. Ferguson, the senior Editor of the "Ceylon Observer," I was enabled to secure works on practical bee-keeping, and by carefully reading these I endeavoured to improve the primitive means adopted by the native apiculturists, but without success. My thanks are also due to E. T. Sharpe, Esq., and R. Morris, Esq., who encouraged me much in the pursuit of my experiments by getting out for me English bee-hives and apparatus for working them.

There are four species of honey-bees in Ceylon:—

- 1.—*Mi-Ḷ*: *Apis Indica*;
- 2.—*Dandawē*—*අඳුරු*: *Apis Florea*;
- 3.—*Bambarā*—*බර්බ*: *Apis Horvata*; and
- 4.—*Kana Veyiyā*—*කනවේයියා*: *Trigona*.

The *Mi Messé* (*Apis Indica*) is the common honey-bee of Ceylon, and the only species kept by natives. I have had a few colonies of these from the very beginning, and in the way of improvement I have transferred them to pots of quite a different shape from the ordinary narrow-mouthed pitchers used by natives, which required the destruction of the pot to get at the honey, thereby causing considerable destruction to bee-life. The pots I substituted are in two sections: the first section or entrance narrow-mouthed and of large which are

into the second, which is flat and deep. When the first section, or mouth-piece with an opening of about 10 in. across, is taken up, the honey-combs are easily removed without any injury to the combs or to the bees, saving the brood combs intact within it. Directly the honey-combs are removed the mouth-piece is again replaced, tied fast, and placed in its proper position, when all the bees return to it and begin to work as if they were never disturbed. At this critical stage, however, they are fed for a few days with jaggery and water, which is made into a thin light syrup, and placed close to the mouth of the pot in a flat vessel. In this manner I have always had a supply of honey for house use, and occasionally to spare for my friends. With regard to the English bee-hives, I have made little or no progress with them. The bees take to them easily, but it is an elaborate and long process to keep them as long, as they shew a disposition to get out. By continual feeding they may be regularly established in them, and when once established they keep on and build their combs and fill the stock hive; but I have never been successful in inducing them to take to supers, which may be attributed to my want of ingenuity and experience to adapt the frames to their mode of comb-building, or to the bees preferring pots, which are I believe cooler than the boxes.

The bees are easily moved about in combs in frame boxes, and hence it is my impression that they can be by competent persons easily reared according to the European system, and with profit and advantage.

The native system of bee-keeping is very simple indeed. They invariably sweeten the pot intended to be used as a hive by fuming it with resin, and place it in a cool elevated position, securing the mouth of the pot with a little honey during the swarming season. The wild bees take to them without the least trouble and begin building their combs, and filling them. When the proper season comes round they break the pots, blow into them to drive the bees aside, and abstract

all the honey as well as the brood combs; the former they retain, and the latter are thrown away, a great waste of material and reckless destruction of bee-life. When the next swarming season comes round, which is between March and April, a fresh pot is fumigated with resin, is placed in the same position as the next supply of honey, which is obtained in July or August. The largest supply the natives so obtain is about three or four bottles of liquid honey. With regard to the wild bees, the natives have in the crevices and hollows of rocks and trees, which are removed by bee-hunters in proper season, and which they consume the produce of their labour, and abandon the empty combs and betake themselves to the woods; and it is generally believed by the natives, that when the swarming season comes round they return to their old haunts and set to work again.

Dactylis.—*Dactylis* (*Apis Florea*) is an unprofitable bee, producing very little honey. It attaches its solitary semi-circular comb by 5 in. to the branch of a tree. Its honey is valued by the natives as being cool and nice, but this species is not well adapted for rearing purposes, as its produce is very

small. *Dactylis* (*Apis Dornata*) is a large bee prettily marked with yellow and black, and makes a large quantity of honey, about two to three gallons. It constructs its hive, a large comb about 3½ ft. by 2½ ft. in a peculiar shape, attaching it to the branches of very lofty forest trees, or securing it to the sides of high rocks with its two ends fastened up, and having a narrow opening in the middle. It is with great difficulty got by bee-hunters, and only by those used to such kind of work.

At the proper season three or four experienced men start on the expedition armed with knives and ropes and a quantity of straw and other materials (for smoking and harrying the bees). Having reached the woods where the bees are located the hunters commence operations on a calm day. First they

out the bees by a heavy fire of straw, when the bees fly high in the air in a straight line; meanwhile one of the hunters cuts the hive, and lowers it down by means of a rope attached to a basket, and hastens down in time to avoid being stung; his companions, who preceded him, throw the hive into the fire directly it comes down, in order to burn all the straggling bees in the comb, and remove away the hive at once, for the Bombaras when provoked are very persistent in stinging, and the poison is as potent as that of a wasp. People are known to have died of the death by swarms of these. This is not to be taken as a warning, considering that they go to work without any of the usual precautions. It is believed—and my experience confirms the belief—that they do not rebuild their combs, but place anew a portion of the comb is left in the hive, and the queen bee uninjured. The honey of this bee is highly esteemed, and is considered an excellent luxury among the natives. It is not however so thick as the *Dornata* bee honey. I have never heard of any attempts being made by natives to domesticate them like the common honey bee of Ceylon; and it is my impression that any amount of attention to domesticate them will prove fruitless. One of the peculiar characteristics of this species is that, unlike the common bees, they go about gathering materials for the construction of their hives only during the evening twilight, and myriads of them are seen at that hour in the Mora, Kōu, and other flowering forest trees during the season.

4th. — *Kava Veyiyā* (a tiny bee belonging to the *Trigonæ*), produces a small quantity of honey which it makes in the hollows of rotten trees and crevices of rocks and dilapidated buildings. I have seen and examined a great many of these combs, which are irregular in shape; they never yield more than a tea-cupful of honey, which has a rather acid taste, and is only used for medicinal purposes. Their combs are generally about four or five inches in circumference, and the cells partially filled

Appendix 12.1: The First Document on Beekeeping in Sri Lanka.

No. 23:--1881.]

SEE CULTURE.

31

with honey and the rest with their brood, like other honey bees, and kept separate. When interfered with or disturbed, they would buzz about one's ears and nostrils, but in other respects they are perfectly harmless and may be easily handled.

Since writing the above I have been taken by surprise by Mr. Benton, a good authority on Bee Culture. His visit to Kurunegala is for the purpose of hunting for the Bambará (Apis dorsata). A narration of his valuable experience has afforded me much information, and I indulge in the hope that this will enable me to compete with my difficulties more successfully in the future.

A person of Mr. Benton's acknowledged ability and experience would do much for Ceylon in opening up a branch of industry so easily conducted and yielding so large a return, but of which the natives are so lamentably ignorant.

Facsimile of the Published Lecture of Mudaliyar Samuel Jayatillake delivered to Royal Asiatic Society on 1881 April 07th. (Page 31 of the RAS Journal)

Figure 12.1: The first Beekeeping Handbook Published in Sri Lanka.

BEEKEEPING IN CEYLON

BY

A. P. GOONATILLAKE.

Halgampitiya, Veyangoda.

පුළුතැන්විට ලියැවුණ සර්වමුහුර්තය

හෙවත්

පුළුතැන්විට ලියැවුණ විනාශය.

— (මු) —

වේදනාකාරී ප්‍රකාශනවලින්

ඒ. පී. ගුණතිලක

සිසිල්

සම්පාදකයා.

— — —

හෙතරජගොඩ

ලංකානිලක මුද්‍රාපත්‍රාලය

මුද්‍රිතයි.

—

1916



මෙහි සඳහන් පෝෂණය කිරීම සඳහා සේවය කළ
නා ර හ ස භා ව.

The Beekeeping Manual written and published by Mr. AP Goonatillake (right bottom) in 1916 and some of the early personalities active in the field of Beekeeping. (top right is Mr. C Driberg)

PREFACE.

Rational beekeeping, based upon modern humane methods, has come to be adopted in Ceylon only within the past few years, and that, too, by but a limited number of amateur apiarists. A comparatively large amount of honey and wax is still being taken from our forests by the crude and cruel practice of driving away, and often killing, the bees with the aid of the torch and other barbarous means.

The earliest pioneer in the attempt to introduce rational apiculture was Mudaliyar C. Jayatilleke of Kurunegala. After him came Mr. J. H. Holloway of Wattegama, and Mr. W. H. Wright of Mirigama, followed by Mr. Chas Andree of Kurunegala: all of whom adopted various types of boxhives in rearing the common honey bee of the East, while some also experimented with European (chiefly Italian) bees.

The nucleus of the movement for the encouragement of beekeeping in the Island was the small apiary started by the writer at the late School of Agriculture. In 1904 the Ceylon Agricultural Society appointed a committee with Mr. J. Harward as Chairman, and the following members:- Messrs. E. E. Green (Govt. Entomologist), M. Shanks, C. Drieberg, Herbert Campbell and A. P. Goonatillake. The Society is specially beholden to two gentlemen for the active and sustained interest they have taken to prove the advantages of modern apiculture, as carried on in England, America, Australia and the Continent. I refer to Mr. M. Shanks and Mr. A. P. Goonatillake.

ii.

The former, who possesses a sound knowledge of the life history and habits of the honey bee, and has considerable experience of hive-manipulation, has acted in the role of "guide, philosopher and friend" to all who have sought his assistance; while the latter, with the facilities available to a country gentleman with ample means at his disposal, has made the fullest use of the opportunities presented to him for carrying out experiments and making demonstrations on an extensive scale. Mr. Goonatillake's book on the subject, written for the benefit of his countrymen, is only another example of his anxiety to popularise rational beekeeping and establish it as an industry. In the West Indies apiculture has, within a comparatively few years, risen to considerable importance, and the similarity of conditions there and here leads one to hope that the same success will attend our efforts in Ceylon. If ever such success is attained the credit will be in no small measure due to the author of this work, on the preparation and publication of which it is evident he has expended much time and trouble. The great value of the book lies in the fact that the writer is not a mere compiler but has carried out in actual practice what he preaches.

I would commend the work to the notice of all who have opportunities of taking up beekeeping and of pushing it as a home industry in the villages of Ceylon.

Pemdeniya,
11th May, 1915.
C. DRIEBERG,
Secretary, C. A. S.

The Preface written by Mr. C Drieberg, for Mr. AP Goonatillake's Beekeeping Manual reveals the early history of Beekeeping in Sri Lanka (Ceylon).

13. INDEX

Animal (ani.)	Plant (plt.)	Place Name (p.n.)
9-ODA 13, 204		
9-oxo-2-decenoic acid 13		
abdomen 32-35		
abscond 13		
absconding 13-14, 23, 28, 42, 50, 53, 149, 154, 157, 159, 162, 164, 182, 190, 209		
absconding causes 149		
absconding due to starvation 149, 154		
absconding emergency 158		
absconding impulse 74, 94, 115, 154, 155, 157,		
absconding prediction 149		
absconding prevention 149, 155, 157		
absconding propensity 149, 155		
abundance of nectar 124		
abundance of pollen carriers 154		
acceptance of the queen cell 135		
adult worker 30		
age determined polyethism 31		
age of queens in honey producing colonies 141, 142		
agricultural planning 193		
Agricultural Research Institutes 203		
agro-chemicals 168		
agro-ecosystem 168, 192		
agronomic practices 197		
air-conditioning 28, 30		
alarm pheromone 14		
Albizia (<i>A. lebeck</i> : Leguminosae) (plt.) 43, 54		
alien environment 165		
alimentary canal 34		
Alkali bee (<i>Nomia melanderi</i> : Halictidae) (ani)193		
allele composition 200		
alleles 199		
Alley, H 79		
altruistic act 31		
altruistic behaviour 31, 209		
American Bee Journal 215		
	Ampara (p.n.) 208	
	analysis of factor 196	
	Andrenidae (ani.) 194	
	animal behaviour and neuro - physiology 14	
	animal husbandry 55, 197	
	animal kingdom 2	
	animals associated with the nest of mee bees 165	
	Ant & Bee conflict 158	
	antenna 32-35	
	antenna comb 32	
	antennate 13	
	Anthophoridae (ani.) 194	
	Antigonon (<i>A. leptopus</i> : polygonaceae) (plt.) 43, 45	
	Ants 1, 2, 6, 8, 35, 149, 154, 165	
	Anuradhapura (p.n.) 208	
	anus 33-34	
	apiarist 4	
	apiary 4, 164, 178, 184, 209	
	apiary layout 52, 188	
	apiary site-selection 50, 52, 115	
	apiary sizes 185, 186, 187	
	Apicultural Abstracts 215	
	apiculture 4	
	Apidae 1, 3, 194	
	Apidologie 215	
	Apiology 8 (see Mellitology)	
	Apis 3	
	<i>Apis andreniformis</i> 3	
	<i>Apis cerana</i> 3, 7, 11, 13, 23, 25, 42, 65, 154, 202-203	
	<i>Apis cerana indica</i> 4, 5, 62, 82, 188, 189	
	<i>Apis dorsata</i> 3, 4, 5, 25, 42	
	<i>Apis florea</i> 3, 4, 6, 25, 42	
	<i>Apis koschevnikovi</i> 3, 23	
	<i>Apis laboriosa</i> 3	
	<i>Apis mellifera</i> (Western honeybee) 23, 141, 189	
	Apoidea 1, 2, 3, 8	
	appearance of drone brood 124, 126	
	appearance of queen-cells 124	
	appliances - beekeeping 73	
	Apterigota 2	
	areas of eggs 94	
	Arecanut (<i>Areca catechu</i> : Palmae)146	
	Aristotle 14	
	artificial control of queen-cells 135	
	artificial factors 197	
	artificial insemination 198, 200, 203	
	Asiatic bee mite <i>Varroa (Varroa jacobsoni</i> : Varroidae: Archinida) 167	
	Asiatic honeybee (<i>A. cerana</i>) 167	
	Ath thora (<i>Cassia alata</i> : Leguminosae) (plt.)196	
	auricle 32-33	
	Australia 188	
	Austria 79, 198	
	auxiliary appliances 78	
	auxiliary tools 73, 74	
	avoid predation by birds 167	
	Ayurvedic drugs 188	
	Bacteria 168	
	Badulla (p.n.) 42, 208	
	Badulla district 118	
	Baker, SW 43	
	balling queen 13, 157	
	Bambara Bee (<i>A. dorsata</i>) 4-5, 14, 23-24-25, 53-54, 59, 63, 81, 170, 178, 193	
	Bambara Bees - night foraging 23	
	banana fibre 75, 80	
	Bandarawela (p.n.) 53, 208	
	Bandarawela areas 47	
	Bandarawela region 118	
	Baptist, BA 44, 63, 191	
	batik industry 82	
	Batticaloa (p.n.) 208	
	Bed bugs (ani.) 2	

- Bee & Ant conflict 158
 Bee 1, 209
 bee behaviour 64
 bee breeding 192
 bee brush 74, 134, 175
 bee chain 96
 bee culture 200
 bee dance 14, 16, 24, 26
 bee diseases 167, 189
 Bee eaters (family: *Meropidae*)
 (ani.) 165
 Bee eating birds 189
 bee escape 79
 bee fauna 207
 bee forage 43
 bee hissing 26
 bee intensity of pollen supply
 150
 bee leg - parts of 33
 Bee Louse (*Braula coeca*:
 Diptera) (ani.) 11
 bee milk 28, 209
 bee pests 157-162, 165-169,
 189-190
 bee population 41, 81
 bee products 51
 bee services 51
 bee space 57, 59, 60, 62, 68, 79
 bee strands 94
 Bee World 215
 bee yard 4
 Beekeeper inventory 181
 beekeepers 4, 181, 183
 beekeeping 22, 41, 181
 beekeeping appliances 73-74,
 192
 beekeeping beginner 181-182
 beekeeping - how to start 181-
 182
 beekeeping technology 191
 beekeeping tools 73-74
 beekeeping training 181
 beekeeping with Mee Bees 181
 Bees 1, 2, 3, 8, 209
 Beetles 3, 64
 beginner 181, 182
 behaviour of the animal 55
 behavioural adaptations 29
 behavioural deviations 154
 behavioural modifications 55
 bellows 170, 172-173
 Benton, F 63, 218
 Betel nut palm (*Areca catechu*:
 Palmae) (plt.) 146
 Bingham, T F 79
 birds 165
 Black German bees 200
 body hair of bees 32-33
 body parts 32, 35
 Bokalawel (*Derris uliginosa*:
 Leguminoceae) (plt.) 44
 boron treated Rubber wood 74
 bottom bar 81
 bottom board 66
 brace combs 60
 Bracheria (*B. brizantha*:
 Graminae) (plt.) 45
 branched hairs 32
Braula coeca (Bee louse) 11
 brain 34
 breeding and improvement of
 honeybees 197
 breeding and improvement
 programme 203
 breeding bees 198
 breeding farm animals 198
 breeding gene pool 206
 breeding high quality bees 207
 breeding queens 164
 Britain 63
 British hive 63
 brood 8, 84, 209
 brood box 59, 66, 71, 73, 85,
 106, 115, 128, 130, 135, 145,
 148, 209
 brood box examination 173
 brood box examination time
 requirement 125
 brood chamber 59, 65, 81, 90,
 105-106, 111, 174
 brood comb 94, 102, 130, 155
 brood combs 72, 102, 105, 128,
 137-138-139, 165, 171
 brood diseases 167, 189
 brood incubating temperature
 158
 brood nest (brood chamber) 85,
 88, 95, 98, 102, 108, 150,
 154, 176
 brood rearing 59
 brood rearing ability house bees
 124
 brood rearing - antipathy 149
 brood rearing - disinclination for
 154
 brood rearing - propensity 155
 brood rearing - temperature 160
 brood section 9
 broodlessness 154
 brushing the nurse bees 133
 Buckfast bees 200
 Bugs 2
 Burnens, Francois 78
 burning chamber 170
 burr combs (brace-combs) 60
 Burutha (*Chloroxylon swietenia*:
 Rutaceae) (plt.) 44
 Butler, C G 63
 Butterflies 3, 204
 Calliandra (*C. calothyrsis*:
 Leguminoceae) (plt.) 43, 49
 candy paste 156
 cannibalism 154
 cannibalistic behaviour 164
 Cardomon (*Ellettaria cardamo-
 mum*: Zingiberaceae) 193
 carnivorous wasp 1
 Carpenter bees (*Xylocopa*
 species) 1, 193-196
 Cashew (*Anacardium*
occidentale: Anacardiaceae)
 (plt.) 43
 caste differentiation 31
 castes 29
 cattle owners 188
 causes of absconding 149
 causes of swarming 121
 Cedar (*Cedrus* sp.) (plt.) 74
 cell 9, 10, 209
 Central Apiculture Unit 181
 Central Europe 198
 centrifugal extractor 175
 centrifugal honey extractor 70,
 79, 179
 Ceylon Beekeepers' Association
 63
 chains of bees 94

- chemical treatment 189
 Chinese 198
 chromosomes 199
 citral 14
 claw 33
 clay tiles 66, 71
 cleaning 28
 cleaning bees 30
 cleaning behaviour 150, 154, 159
 climate 196
 climatic changes 174
 climatic conditions 41-42
 climatic potential 41
 climatic zones of Sri Lanka 42, 208
 Coconut (*Cocos nucifera*: Palmae) (plt.) 36, 43, 194
 coconut coir 134
 coconut husk 170, 173, 175
 cocoon 81
 Coffee (*Coffea arabica*: Rubiaceae) (plt.) 43
 cohesion 14
 coir rope 74
 Coleoptera (ani.) 3
 collecting natural colonies 147
 collection of swarms 145
 Colletidae (ani.) 194
 Collins, A 79
 Colombo (p.n.) 208
 colonial country 191
 colonies 182
 colony 8, 14, 41, 209
 colony condition 190
 colony dividing 94, 130, 132
 colony examination 86
 colony growth rates 91
 colony layout 134
 colony life 13
 colony maintenance 181
 colony members 27
 Colony Performance Index (CPI) 150, 155, 162
 colony population 114
 colony productivity 202
 colony size - optimum 106
 colony volume 41
 comb 5, 8, 9, 10, 210
 comb area 95
 comb breakage 80
 comb breakage and repair 75, 76, 80, 147
 comb building 28
 comb building bees 30
 comb examination 125
 comb foundation 68, 70, 75, 79, 82, 85, 87
 comb guide 67-69
 comb space 59, 95
 comb space management 95
 comb spacing 60, 62
 comb thickness 59, 60
 comb transfer after uniting 113
 comb transferring 102, 106
 combs 8, 210
 combs storage rack 120
 commercial bee breeder 141
 commercial honey production 50, 207
 commercial production of honey 50, 207
 communal nesting 54
 communication 13-14, 23, 210
 communication centre 26
 communication dance 13-24
 communication in honeybees 13
 communication signals - chemical 14
 communication signals - physical 13-4
 comparison - worker & drone brood 128
 competition for food 53, 188
 compound eye 32-33
 condition of the brood combs 128
 condition of the colonies 155
 conflict between Ants & Bees 158
 confusion among the bees 37
 congestion 121
 congestion in the brood chamber 141
 congestion in the hive 86
 conservation farming 168, 192
 contamination of honey 189
 continuation of growth 102
 control mating 198, 202-206
 controlled natural breeding 205
 Controlled Natural Breeding Experiments 204, 205
 Controlled Natural Breeding Method 202, 206
 Coral vine (plt.) (see Antigonon) 43
 corbicular (pollen basket) 32-33
 cost factor 50
 cost of beekeeping appliances 182-187
 cost of feeding 188
 cost of production 164
 cost of supplementary feeding 183-187
 costs and returns of beekeeping 184-187
 court bees 30
 court formation 7, 11, 13
 CPI (Colony Performance Index) 150, 155, 162
 coxa 33
 crop (honey stomach) 34-35
 crop pollination 4, 194, 195
 crop pollination requirements 193
 crop production 207
 crown board 66, 71, 164
 Cypress (*Cedrus sp.*) (Plt.) 74
 cytological incompatibilities 203
 cytoplasm 199
 Dadant, H 79
 Dammar bee 4
 Dammar honeybees 6
 Damsalfies (ani.) 2
 dance 15-23, 210
 dance communication 13-25
 dance following 15-16, 19-20, 30
 Danduwel bee (*A. florea*) 4, 6, 14, 23-24-25, 59, 81, 162, 193
 daughter colonies 115, 142
 dead brood 147
 dearth period 95, 115, 118, 154, 164, 190
 decline of the colony population 114

- defence behaviour 150, 154, 157, 160
- deliberately finding the queen, the need for 94, 129
- deliberately seeing the queen 94, 129
- Demaree, GW 79
- Dep, AC xiii
- desertion of nest site 149, 209
- detached sting 39
- detergent 178
- devastating diseases of honeybees 167, 189
- development of apiculture 207
- Digger bees (ani.) 194
- Dimiya (weaver ant) (*Oecophylla smargnida*: Formicidae) 161
- Dimiya problem 162
- Dimiyas 158
- diploid 28, 199
- Diptera (ani.) 3, 11
- diseases 167
- diseases of Western honeybee 167, 189
- disinclination for brood rearing 154
- distribution of honey stores 176
- disturbance of the brood 149, 154
- dividing 137, 210
- dividing colonies 139
- dividing for colony multiplication 68
- division of labour 29, 31, 210
- division of labour - caste determine 31
- Division of Labour - morphological 31
- Divul (*Feronia limonia*: Rutaceae) (plt.) 44
- Diyatalawa (p.n.) 54
- donor colony 135, 155
- Doolittle, GM 79
- Dragonflies (ani.) 2, 204
- Drieberg, C 63, 215, 219-220
- drone & worker brood comparison 128
- drone 8, 10, 27, 28, 210
- drone brood 106, 124, 126, 128, 167, 171
- drone brood in newly built combs 124, 126
- drone cells 125, 126
- drone combs 28, 106, 126
- Drone Congregation Area (DCA) 27-28, 167, 202, 204, 206
- drone flight 124, 202
- drone flight period 27-28, 124, 202
- drone laying colonies 142
- drone production 163
- drones 28, 35, 201
- Drongos (family: *Dicruridae*) 165
- dry season 42
- Dry Zone 42, 44, 53, 208
- dry zone forest 43, 48
- dry zone honeys 48
- Dufour's gland 34
- dummy board removal 111
- dummy board 70, 73, 66, 95, 98, 114, 138, 140
- dummy queen 204
- Dzierzon 198
- eco-climatic conditions 42
- eco-climatological 62
- eco-climatological zones 207
- eco-system 168
- economics of beekeeping 113, 181
- educationally privileged classes 191
- effective pollination 193
- effective smoker 79
- egg 9-10, 27
- egg laying 7, 27, 86, 97, 139, 141
- egg laying machine 94
- egg laying queen 7, 27, 200
- egg laying rate 27, 124
- eggs 9-10, 27
- electronic recorder 158
- electronic temperature feelers (thermistors) 158
- Elawara (see Wara) (plt.) 196
- Ella (p.n.) 54, 208
- Elpitiya (p.n.) 208
- emergency absconding process 158
- energy conservation 26
- entrance guard 71, 73, 155
- environment 41, 199
- environmental conditions 42, 95, 158
- environmental deficiencies 168
- environmental factors 196-197
- environmental pressure 189
- environmental potential 41
- environmental shortcomings 190
- epipharynx 34
- Eucalyptus (*E. robusta*: Myrtaceae) (plt.) 118
- Eucalyptus plantations 53
- Europe 167
- evolution 1, 189
- excessive swarming 121-123
- expanding the nest 98-110
- expenditure 184-187
- expenditure for beekeeping 182-187
- extra floral nectaries 46
- extracting honey 178
- extraction of honey 115, 178
- extractor 175, 179, 180, 182
- eye brush 32
- eye - compound 32-33
- eye - simple 33-34
- Fabritius, Mi 24
- Fabritius, Mo 24
- Factor analysis of honey production 196-197
- failures in beekeeping 64
- family nutrition and income 192
- fanning bee 35, 38, 174
- feedback mechanism 26, 210
- feeder 73, 100, 163, 166
- feeder can 140, 162, 164, 166
- feeders 162
- feeding bees 163
- feeding pollen substitutes 164
- feeding small colonies 162
- feeding sugar 164
- feeding the queen 28
- femur 33

- Fernando, EFW 44
 fertile female 28, 29, 198, 199
 fertilizer usage, 196
 field bees 30
 field crops 193
 filial generation 200
 finding the queen when
 necessary 129
 Flies (ani.) 3
 flight muscles 34
 flight range (see foraging range)
 22, 35, 50, 188, 189, 197
 floor board (cement) 65
 floor board (combined with hive
 stand) 74
 floor board (wooden) 65
 floor board 40, 64, 66, 69, 73,
 75, 81, 154, 210
 Flower mite (*Neocypholaelaps
 indica*: Acarina) (ani.) 167,
 169
 flower visiting insects 1
 flowering plants 32
 flying mature drones 124
 food processing 28
 food supply 98
 forager population 41
 foraging area (see flight range)
 50
 foraging bee 12, 14, 30
 foraging population 141
 foraging range - long
 A. mellifera 189
 foraging range - short *A. cerana*
 22, 35, 188
 foraging range 41, 50, 188-189,
 210
 fore leg 32
 fore wing 33
 forest fire 36
 Formicidae (ani.) 2
 frame 69, 81
 frames 82, 85, 125, 163
 frames or top-bars - suitability
 65, 68
 France 79, 198
 Free, JB 14
 freezing combs for killing wax
 moth larvae 116
 fresh comb 84
 friction lid cans 162
 friendly environment 192
 Frisch, KV 14
 fructose (mono-saccharides) 35
 Fruit flies (ani.) 3
 fruits & vegetables 193
 Fuchs, S 26
 functional queen 141
 Fungi 168
 future of beekeeping 193
 Gadawski, R 20
 Galle (p.n.) 208
 Gampaha (p.n.) 208
 Garden Lizards (ani.) 165
 Geckos (*huna*) (ani.) 165, 167
 gemete 199
 genes 199
 genetic improvement 197
 genetic incompatibilities 203
 genetic manipulation 200
 genetical factors 196-197
 geraniol 14
 Germany 79, 87, 198
 Gherkins (*Cucumis anguria*:
 Curcubitaceae) (plt.) 196
 Giant Honeybee 4, 5
 Gingilly (plt.) (see *Tala*) 43
 Ginisapu (*Michelia champaca*:
 Magnoliaceae) 74
 Glenings in Bee Culture 215
 Gliricidia (*G. sepium*:
 Leguminosae) (plt.) 43
 glossa 34
 glucose 35
 Golden Italian bees 200
 gonads 29
 good defender 190
 good producer 190
 Goonatillake, AP 63, 215, 219-
 '220
 Grass hoppers (ani.) 2
 gravitational direction 16
 gravity 81
 grease 162
 Greater Wax Moth (*Galleria
 mellonella*: Pyralidae) (ani.)
 82
 Grimm, A 79
 growth of the population 114
 growth period 118, 190
 growth phase 95
 guard bees 30, 31, 38
 guarding 28, 35
 gut 34
 hair 33
 hair - plumose 33
 hair - simple 33
 Hakgala (p.n.) 53
 Halictidae (ani.) 194
 Hambantota (p.n.) 208
 haploid 28, 199-200
 Haputale (p.n.) 54, 208
 Harbison, JS 79
 harmonious coexistence of
 honeybees and pests 165-
 168, 189-190
 harmonious living 189
 harmony 168
 harmony between bees and
 enemies 167-168
 head - honeybee 32-34
 healthy colony 94, 96
 Hemiptera (ani.) 2
 herbivorous 1
 heterozygous 199
 heterozygous diploid 200
 Hexapoda (ani.) 2
 high stocking rate 163
 high temperature bee cluster
 158, 160
 high yielding varieties of rice
 182
 hind leg 32
 hind wing 33
 hive 8, 40, 55, 57, 182, 210
 hive - to take the blame for
 failures in beekeeping 64
 hive-construction 74
 hive design criteria 62
 hive designing 59
 hive entrance 171
 hive honeybee 3-4, 81, 193
 hive location 37, 40
 hive manipulation 68, 75
 hive position 36
 homeostasis 7, 11, 13, 213
 homogenous paste 165

- Homoptera (ani.) 2
homozygous 199
homozygous diploid 200
homozygous offspring 201
homozygous sex allele combination 199
honey 165, 182, 210
honey maturity 174
honey as a medicinal food 188
honey build-up 170
honey chamber (supers) 59, 66
honey chambers 70
honey collection 192
honey combs sealed 175
honey extraction 118, 134, 174-175, 181
honey extraction procedure 177
honey extractor 70, 73-74, 79, 180, 183
honey extractor - portable 180
honey fermentation 174
honey flow 28, 41, 44, 50-51, 54, 85-86, 93-94, 106, 112-115, 118, 121, 124, 135, 138-139, 141-143, 145, 174, 181-182
honey flow period 95, 174, 190
honey frames (super frames) 67, 89
honey hunters xii-xiii, 63
honey hunting xii-xiii, 43, 57, 207
honey immature 175
honey importation 188
honey making 35
honey mature 35, 175
honey producing colony 133
honey production - factors 196-197
honey production 4, 51, 193, 196-197
honey production colonies 141
honey production in Sri Lanka 190
honey production industry 207
honey removal 175
honey stomach 34-35, 209
honey storage 85
honey stores 28, 102
honey stores in a nest of bees 174
honey supers 59, 66, 70, 72, 82, 210
honey unsealed 9, 175
honeybee brood 10
honeybee communication centre 26
honeybee enthusiasts 146
honeybee mites - parasitic 167, 189
honeybee - pests 157-162, 165-169, 189-190
honeybee population 196
Honeybee Research Centres 208
honeybee workers 32
honeybee's nest 82
Honeybees 1, 3, 4, 82, 194, 210
Honeybees Stinging 3-4, 6
Honeybees Stingless 3-4, 6
Honeybees True 3-4
Hoppers (ani.) 2
Horana (p.n.) 208
Horticultural Research and Development Institute 181
Hornet (ani.) 149, 157-158, 160, 165, 204
hornet - killed by Mee Bees 157-158, 160
hot smoke 170
house bees 12, 30, 35
How to start beekeeping with Mee Bees 181
Howpage,D 149
Hruschka,F 79
Huber,F 78, 198
human habitations 162, 189
hungry bees 146
hungry swarms 146
hybrid *mellifera X cerana*: impossibility 203
hydrogen ballon 204
Hymenoptera (ani.) 1, 2, 199
hypopharyngeal glands 28, 34, 124
IBRA 215
in breeding 200, 207
inactive ovary 11, 210
income 184-187
increase in the density of bees 121
India 190, 198
indigenous (ayurvedic) medicinal preparations 188
initiate egg laying 141
initiating growth 98, 101
inner cover 37, 40, 66, 71, 74, 95, 100, 114, 164
inquilin 11, 210-211
insect and bee pollination 1, 4, 193
insecta 2
insectivorous insects 167, 211
insectivorous predation 167
Insects (ani.) 2, 211
instrumental insemination 79, 198, 203
interaction between honeybee and ants 158
Intermediate Zone 42, 208
International Bee Research Associations (IBRA) 215
intestine 34
inventory of beekeepers 181
investment 182
investment of beekeeping 182-187
investment recovered 174
invisible initial infestation of wax moths 116
irrigation 196
isopentyl acetate 14
Isoptera (ani.) 2
Jaffna (p.n.) 42, 208
Janscha,A 198
Jayasinghe,DM xiii
Jayatillake,S 63, 215-218
Journal of Apicultural Research 215
judging the growth 98, 114
jute strings 75
juvenile stages 27
Kadiya (ani.) 158, 161
Kaha mara (*Peltophroum pterocarpam*: Legaminoceae (plt.) 43
Kalawel (*Derris scandrens*: Leguminoceae) (plt.) 44, 48

- Kalu kuhumbi (ani.) 158
 Kalutura (p.n.) 208
 Kanawe bee (*Trigona*) 4, 6, 193
 Kandy (p.n.) 42, 208
 Kannagara,AW 63
 Karnataka (p.n.)190
 Kegalle (p.n.) 208
 Kerala (p.n.) 190
 Kevan,PG 20
 kidney (vertebrate) 35
 killing a hornet 158, 160
 Kirikon (*Walsura pisida*:
 Meliaceae) (plt.) 44
 Knox,R 43
 Koeniger,G 24, 53, 167, 202
 Koeniger,N 20, 24, 26, 28, 53,
 149, 167, 202
 Kohomba (*Azadirachta indica*:
 Meliaceae) (plt.) 44
 kolapath gotuwa 146, 148
 Kon (*Schleichera oleosa*:
 Sapindaceae) (plt.) 44
 Kumbuk (*Terminalia arjuna*:
 Combretaceae) (plt.) 44
 Kurunegala (p.n.) 208
 labial palps 33, 35
 labial palpus 34-
 labium 33, 35
 labrum 33
 land preparation 196
 Langstroth,LL 57, 79, 189
 larvae 9-10, 211
 larval stage 9, 27
 laying worker 11, 141-142, 211
 Leaf cutter bee (*Megachile*
 rotundata: Megacilidae)
 (ani.) 193
 lean periods 164
 Lepidoptera (ani.) 3, 198
 Lesser wax moth (*Achroia*
 grisella: Pyralidae) (ani.) 82
 lethal homozygous sex allele
 combination 199
 lethal inbreeding 200
 life span 27
 Lindauer,M 23
 liquid transfer 12, 35
 little honeybee 4, 6
 living in harmony 189
 Lizards (ani.) 167
 Locusts (ani.) 2
 log hive 56
 long foraging range 189
 losses from beekeeping 184-185
 low productive honeybee 189

 Lunumidella (*Melia dubia*:
 Meliaceae) (plt.) 74
 Maha dhang (*Syzygium cumni*:
 Myrtaceae) (plt.) 44
 maintain the growth 98
 major predator 167
 malpighian tubules 34-35
 management 181, 197
 management of a colony 81, 127
 management of a nest of
 honeybees 99
 management of honeybees 189
 management of old combs 85
 management of swarming 121,
 129, 181
 management phase 118
 management practices 118, 190
 managing bees 155
 mandibles 32-34
 mandibular gland 13, 34
 Mannar (p.n.) 208.
 Mantids (ani.) 2
 mass attack 158
 mass attack to kill a hornet
 160
 Matale (p.n.) 42, 208
 Matara (p.n.) 208
 mated queen 141, 205
 mating 14, 205
 mating colonies 138, 205
 mating cycle 198
 mating flight 27-28, 205
 mating flight period 124
 mating sign 198, 205
 mature (old dark) combs 81
 mature comb 88-90
 mature honey 9, 35, 177
 mature queen-cells 135-136
 maturity of the honey 174
 maxillae 33, 35
 maximum annual supplementary
 feed 113
 medicinal food 188
 Mee Bee (*Apis cerana indica*)
 hive honeybee 4, 14, 23, 25-
 26, 42, 53, 59, 63, 81, 158,
 161, 167-168, 176, 178, 182,
 193, 195-196, 262,
 Megachilidae (ani.) 194
 Mehring,J 79, 87
 Melipona 3
 Meliponinae 3
 Mellitology 8
 membranous wings 33
 mending broken combs 75-76,
 80
 metamorphosis 9, 27, 211
 Mi (*Madhuca longfolia*:
 Sapotaceae) (plt.) 44
 micro-organisms 168
 middle leg 32
 mid gut 34
 migration 53
 migration of Bambara bees 53,
 207
 migratory beekeeping 50, 211
 mild smoke 170
 mirror box 125, 127, 128, 138,
 171
 mirror box advantages 125
 mirror box usage 128
 mirror box view 128, 142, 143
 mirror box working principle
 127
 Mites (*Arachnida*) (ani.) 167,
 169, 189
 Mites harmless to bees 167
 modernized agricultural 182
 Monaragala (p.n.) 208
 monoculture 168
 moon light foraging - Bambara
 Bees 23
 Mora (*Nephelium longana*:
 Sapindaceae) (plt.) 44
 morphological 29
 morphological adaptations 30
 morphological characters 200
 Mosquitoes (ani.) 3
 moth balls (naphthalene balls)
 116
 moths 3

- mouth parts - honeybee 32-35
movable comb (frame) hives
189
movable comb hive 55, 57, 75,
82, 95, 174
movable combs 60
movable frame 79
movable frame hive 57, 65
movable wall 70
Mullaittivu (p.n.) 208
multiple egg laying 142
multiple eggs 144
Nasonov's gland 12, 14, 34
national development 192
National Museum 181, 195
National Research and
Developments in Beekeeping
181
Native wild bees of Sri Lanka
195
natural adaptations 162
natural colonies 75, 145, 168,
189
natural enemies 155-162, 165,
167-168, 189-190
natural environmental factors
197
natural factor 197
natural foraging dance 22
natural protection from
predatory birds 202
natural reproduction 121
natural requirements of the bees
168
Natural Resource in Sri Lanka
207
natural resources 207
nature conservation 196
nature lovers 146
nectar 43, 164, 211
nectar bees 30
nectar collection 35
nectar secreting plant
community 196, 197
nectar shortage - a cause of
absconding 149
nectar yielding plants 164
Nelu flowering (*Strobilanthus*
spp.: Acanthaceae) 53
Nelu plants 53
nerol 14
nerve cord 34
nest 5, 6, 8, 82, 123, 211
nest architecture 25, 58-59
nest of Bambara Bee 5
nest of Danduwel Bee 6
nest of Kanawe Bee 6
nest of Mee Bee 5, 123
nest site 82, 83, 211
nest size 4
nest volume 95, 152, 163
nesting place 146
nests of honeybees 5, 6
new combs 81, 85
new queens 141
new strains 206
niche 158
night foraging - Bambara Bees
23
non social bees 193
non starving colony 157, 159,
162
non starving swarms 146
notch 32-33
nurse bees 28, 30, 106, 124, 130,
211
nursing 28
nutrition for growing 98
Nuwara Eliya (p.n.) 42, 53, 208
obligatory survival strategy 162
observation colony 152
observing the queen 96
ocelli 33
Odanata (ani.) 2
oesophagus 34
off season feeding 115
Ohiya (p.n.) 54, 208
old (mature) comb 84
old brood combs 71
old combs 81-82, 85, 155
old combs - management 85
old combs shaving off by bees
85
old queens 141
olfactory clue 15
oögenesis 201
optimum honey production 106
optimum nest size 114
optimum population 41
orders of insects 2
orientation pheromone 14
orphan colony 11, 13, 211
Orthoptera (ani.) 2
ovaries 13, 34, 142, 201, 210-
211
ovary 34, 211
over crowding 50
over flow of bees 142
over smoking 36, 171
ovipositor 35
Ovum 199, 201
Palu (*Manikara hexabdra*:
Sapotaceae) (plt.) 44
Panabokke, CR 42
paper method 113, 119
parasite 167, 212
parasitic bee mites 167, 189
parental animals 198
parental generation 200
parthenogenesis 198
parts of a bee hive 66-67
parts of a bee leg 33
Passion fruit (*Passiflora edulis*:
Passifloraceae) (plt.) 193
Passion fruit growers 194
pasture land 188
pectan 32-33
Pelmadulla (p.n.) 208
Peradeniya (p.n.) 181
pest and disease management
196
pest incidence 149
pest status 165
pesticides 168
pests 149, 157-162, 165-169,
189-190
petroleum oil 162
pharynx 35
pheromones 12-13, 212
phoresis 212
phoretic symbiont 167, 169
physical communication 14
physical communication ability
25
physiological 29
Pinus (*Pinus* sp.) (plt.) 74
plain polarized light 20, 23, 212

- plant bugs 2
- Plaster bees (ani.) 194
- plumose body hair 33
- poison gland 34, 39
- poison sack 34, 36, 39
- polarized light 20, 212
- pollen 8, 45, 51
- pollen basket (corbicula) 32-33
- pollen bees 30
- pollen brushes 32-33
- pollen collection 32
- pollen comb 32-33
- pollen dispersing animals 193
- pollen forager intensity 152-153
- pollen forager ratio 152
- pollen foragers 151-152
- pollen gathering activity 150
- pollen grain 32
- pollen incoming rate 149
- pollen production 51
- pollen sources 43
- pollen stores 102, 176
- pollen substitute 164-166
- pollen substitute - feeding 165-166
- Pollen substitute - recipe 165
- pollen supply 164
- pollen supply bee intensity 150
- pollen supply time intensity 150
- pollination 1, 32, 93, 168, 193-196, 212
- pollinators 1, 168, 193-196
- Polonnaruwa (p.n.) 208
- polyethism 30, 212
- polyethism age determine 30, 31
- polyethism caste determine 31
- polyethylene film 165
- polymorphism 31, 212
- polythene bag method 116
- polythene bags 120
- population management 86, 95, 115
- population of honeybees 41, 196
- portable honey extractor 180
- post-honey-flow 112
- pot hive 56
- Potter, EC 79
- pre-honey-flow 112, 118
- pre-honey-flow period 190
- pre-swarming congestion 142
- predation 189
- predation by birds - avoidance 167
- predation by birds 165
- predators 190, 212
- predatory animals 167
- predatory Ants 6
- predicting absconding 149
- predicting the preparation for swarming 124
- preparation for absconding 154
- prerequisites 41
- prerequisites of honey production 41, 86
- preservation of empty honey combs 116
- prevent chilling of combs 147
- prevention of absconding 118, 138, 149, 155
- primary caused of absconding 154
- principles of beekeeping 41
- problem of breeding honeybees 197
- problematic - honeybee 189
- production 51
- production of new colonies 121, 129
- production of old combs 85
- productivity 202
- productivity of colonies 202
- profit oriented beekeeping 183
- profitability of beekeeping 182
- profits from beekeeping 184, 186-187
- prolific queen 86
- proneness to starvation 162
- propodium 23, 33
- prostrate nests 6
- protection to bees 193
- protection with the naturally occurring factors 167
- protective layers of resins 6
- protective resins 162
- protein substitute 164
- proventriculus 34-35
- provision of nest sites 146
- provision of space 114
- provision of sufficient space 94
- pseudo absconding 155
- Pterigota 2
- Punchihewa, RWK 20, 24, 44, 64, 149, 202
- pupa 9-10, 129, 131, 135, 212
- pupae 10, 212
- pupal cocoon 81
- pupal stage 9-10, 27
- Puttalam (p.n.) 208
- queen 8, 27-28, 35, 155, 198, 201, 212
- queen balling 13, 157
- queen cage 156, 212
- queen cage method 157
- queen cell 28, 130, 135-137
- queen cell acceptance 135
- queen cell acceptance/rejection 138
- queen cell transplanting 135
- queen cells 124-125, 129, 131, 139, 142, 171, 212
- queen cells - judging maturity 131
- queen court 7, 11, 13, 212
- queen cups 128-130
- queen dummy 204
- queen excluder 79, 145
- queen guard 71, 155
- queen guard method 155
- queen larva 142
- queen laying in honey supers 145
- queen less colony 113, 135, 137
- queen less division 113, 129-130, 134, 142
- queen pecking 13
- queen pheromone 13, 204
- queen production 163
- queen rearing 79, 192, 212
- queen right 113, 213
- queen right colony 113, 130
- queen right division 129
- queen substance 7, 13, 144, 204
- queenless 113, 138
- Quinby, M 79

- Rambutan (*Nephelium lappaceum*: Sapindaceae) (plt.) 43
 rapid growth period 106
 rapid growth phase 141
 Ratnapura (p.n.) 42, 208
 Ratu kuhumbi (ani.) 158
 raw chicken eggs 165
 rectum 34
 recipient colony 135
 re orientation 37
 re queening 141
 Réaumur 198
 Red gum (*Eucalyptus robusta*: Myrtaceae) (plt.) 43, 47, 53-54, 174
 Red gum growing region 43, 47, 207-208
 reduction in honey yields 121
 reduction in the colony 115
 reduction of the bee population 121
 reduction of the colony population 121
 refrigerator 117
 regurgitates 12, 35
 relocation of hives 36
 removal of honey 175
 removal of the dummy board 111
 renewable resource 192
 reproductive castes 29
 reproductive organs 29, 34, 200
 requeening 106, 113
 reuse of combs 60
 Rice 193
 ritual of absconding 157
 robber bees 138
 robbing 162
 robbing prevention 162
 robbing small colonies by large ones 162
 Robinson, CJ 79
 roof 2, 71, 74
 Root, AI 79
 round dance 15-17
 Royal Asiatic Society 215-218
 royal jelly 28, 213
 royal jelly producing glands (hypopharyngeal glands) 34, 124
 Rubber (*Hevea brasiliensis*: Euphobiaceae) (plt.) 43, 46, 50, 174
 rubber bands 75
 rubber growing 207
 rubber growing areas 118, 190
 rubber plantations 190
 rubber stopper 178, 180
 rural under-employment and unemployment 192
 Sabaragamuwa province 118
 salivary ducts 34
 salivary enzymes 35
 salivary gland 34
 Scorpions (*kiri gonussa*) (ani.) 165, 167
 scout bee 14, 16, 19-20, 26, 29-30
 sealed honey 176
 Sesame flower 195
 selecting apiary sites 115
 selection of strains 206
 selective breeding 200
 self destructive behaviour 31
 self regulating colony dividing method 133
 self regulating - dividing method 130, 134
 Seligmann, BZ xiii
 Seligmann, CG xiii
 Sesame (see Tala) (plt.) 194
 sex determination 198, 200-201
 shaking bee 169
 short foraging range 22, 35, 188, 189
 shortage of food 162
 shortage of nectar 149, 154
 shrinkage of population 115
 shrinking nest 118
 sickle dance 15, 18-19
 side bars 81
 side line business 190
 Silk Moth (*Bombyx mori*: Lepidoptera) (ani.) 198
 Silk worm (ani.) (see silk moth) 198
 simple sugars 35
 Siyambala (*Tamarindus indica*: Leguminosae) (plt.) 44
 size of comb 68
 small colony 98
 small scale local enterprises 192
 smoke 36, 88, 130
 smoke effect on bees 36
 smoke hot 170
 smoke mild 36
 smoker 36, 74, 172-173, 175, 178
 smokers 182, 183
 smoking 35, 135, 170, 173
 smoking - different methods 170
 smoking - suitable fuel 36, 170
 soap 178
 social cohesion 13
 social homeostasis 7, 11, 13, 213
 social organisations 1
 socio economic basis of beekeeping 189
 soil conservation 49
 solar wax melter 82
 solitary bees 1
 somatic cells 199, 213
 somatic tissue 29, 201, 213
 Sophocles 191
 South East Asian Nations 203
 Soybean flour 165
 space requirement 94-95
 sperm 199, 201
 spermatheca 27, 201, 213
 spermatogenesis 201
 Spider (*Arachnida*) (ani.) 165, 167
 spiracles 33
 Spittel, RL xii-xiii
 spur 32-33
 Sri Lanka Bee Farmers Association 181
 Sri Lanka Customs 188
 Sri Lanka Department of Agriculture 63-64, 181
 stabilize the colony 138
 standard flight line (SFL) 22
 starving 154
 starving colonies 157
 sterile females 29
 sterile queen 11

- sticky resins 6, 162
- sting 33-36
- sting apparatus 34
- stinging 14, 35, 160
- stinging bee 39
- stinging honeybees 4, 59
- stinging reaction 170
- Stingless Bees 3-4
- Stingless Honeybees 3-4
- storage of empty honey combs 116
- storage of empty super combs 120
- stored honey 8, 84
- strands of bees 94
- sugar 165
- sugar paste 157
- sugar solution 162
- sugar syrup 155, 164, 166
- suitable hive 63, 64
- suitable hive design 66
- suitable timber 74
- Sun flower (*Helianthus annuus*: Compositae) (plt.) 194
- super 102, 105
- super frames 102
- super organism 1, 29, 213
- supersedure 213
- supplementary feed - maximum limit 113
- supplementary feeding 50, 86, 98, 100, 106, 118, 149, 162-164, 189, 202, 213
- survival 14
- survival strategy 162
- suspended nests 5, 6
- sustainable agriculture 168
- swarm 83, 145, 148, 213-214
- swarm control 79, 114, 139, 142
- swarm management 86, 94, 118
- swarm stabilizing 146
- swarming 8, 14, 23, 28, 82, 106, 121-124, 135, 138, 141-143, 190, 213-214
- swarming impulse 115, 124-125, 130, 134, 138
- swarming season 141, 213
- swarms 155
- swarms of bees 146
- Sweat bees 194
- symbiont 169, 214
- tail wagging dance 15, 19-20, 22
- Tala (*Sesamum indicum*: Pedaliaceae) (plt.) 43
- Tamil Nadu (p.n.) 190
- Tarentula (*divimakaluwa*) (ani.) 167
- tarsi 32-33 (see tarsus)
- tarsus 32-33 (see tarsi)
- technology 191
- temperate 189
- temperature regulation 95
- Tergite glands 13, 34
- termite attack 74
- Termites 2, 8, 64
- thermistor 158
- thickness of the brood combs 62
- thorax 32-35
- through-bred-bees 203
- Thunbergia (*T. grandiflora*: Acanthaceae) (plt.) 196
- tibia 32-33
- tibula 32-33
- time intensity of pollen supply 150
- tongue 33, 35
- top-bar 12, 67-69, 80, 88-89, 97, 103, 137, 214
- top-bars 65, 68, 73, 85, 125, 147, 156, 173
- top-bars or frames - suitability 65, 68
- traditional beekeeping 198
- traditional industry 189
- traditional medical practice 188, 207
- transfer of old brood combs 121
- transplanted queen-cell 135
- treatment against diseases 190
- Trigona irridipennis* (ani.) 3, 4, 6
- Trincomalee (p.n.) 208
- trochanter 33
- tropical Asia 189
- tropical Asiatic region 198
- tropical environment 189
- tropical monsoonal forest 189
- True Honeybees 3-4
- UK (United Kingdom) 215
- unbranched hairs 32
- uncapped honey 179
- uncapping 178
- uniting colonies 113, 118-119
- uniting colonies - paper method 113
- unsealed honey 176
- USA 79, 87
- use of older brood combs 87
- Uva province 43
- Varroa mites (*Varroa Jacobsoni*: Varroidae) (ani.) 167, 189
- Vavuniya (p.n.) 208
- Vedda xii-xiii, 191
- vegetables and fruits 193
- ventilating holes 66, 71
- ventilation method 117
- vertebrate animals 33, 55
- vertical comb 15
- viable economic proposition 113
- virgin queen 8, 202
- vitamin B complex 165
- vitamin C 165
- Vorwohl,G 53
- wagging bee 169
- Waggle dance 15, 19-21
- Waite,MB 79
- Wara or Ela wara (*Calotropis gigantea*: Asclepiadaceae) (plt.) 196
- wasps 1, 2, 8, 35
- water carrying bees 28, 30
- Watson,LR 79, 198
- wax 51, 214
- wax extraction 82
- wax glands 8, 30, 32, 34
- wax moth 82, 150, 154-155, 157, 159
- wax moth infestations of combs 154
- wax moth invasion 115
- wax moth larvae 64, 115-116
- Wax Moths - greater (*Galleria mellonella*: Pyralidae) (ani.) 82
- Wax Moths - lesser (*Achroia grisella*: Pyralidae) (ani.) 82
- wax moths 149, 165

wax production 4, 51, 193
 wax scales 33
 wax sealing 178
 weather conditions 42
 weaver ant problem 162
 Weaver Ants (*Oecophylla smaragnida*: Formicidae) (ani.) 158
 Wedelia (*Wedelia biflora*: Compositae) (plt.) 43
 Weera (*Drypetes sepiaria*: Euphobiaceae) (plt.) 44
 Weiss,F 79, 87
 Welimada (p.n.) 54, 208
 Western honeybee (*Apis mellifera*) 145, 167, 203
 Western 118
 Western honeybee - problems 167, 189
 Western nations 198
 Western province 118
 Westerners 198
 Wet Zone 42, 208
 Wijayagunasekara,HNP 28, 167
 wing - fore 33
 wing - hind 33
 wing - hooks 33
 wing - groove 33
 wired comb foundations 70, 75
 worker 27-28, 214
 worker & drone brood-comparision 128
 workers 8, 35
 worker bees 141, 200
 worker brood 126, 128
 worker castes 29
 workers eat the young larvae 164
 xenobiotics 168, 214
 Xylocopa (Carpener bees) (ani.) 1, 195
 young queen 131, 205
 Zinnia (*Z. elegance*: Compositae) (plt.) 45

About the Author

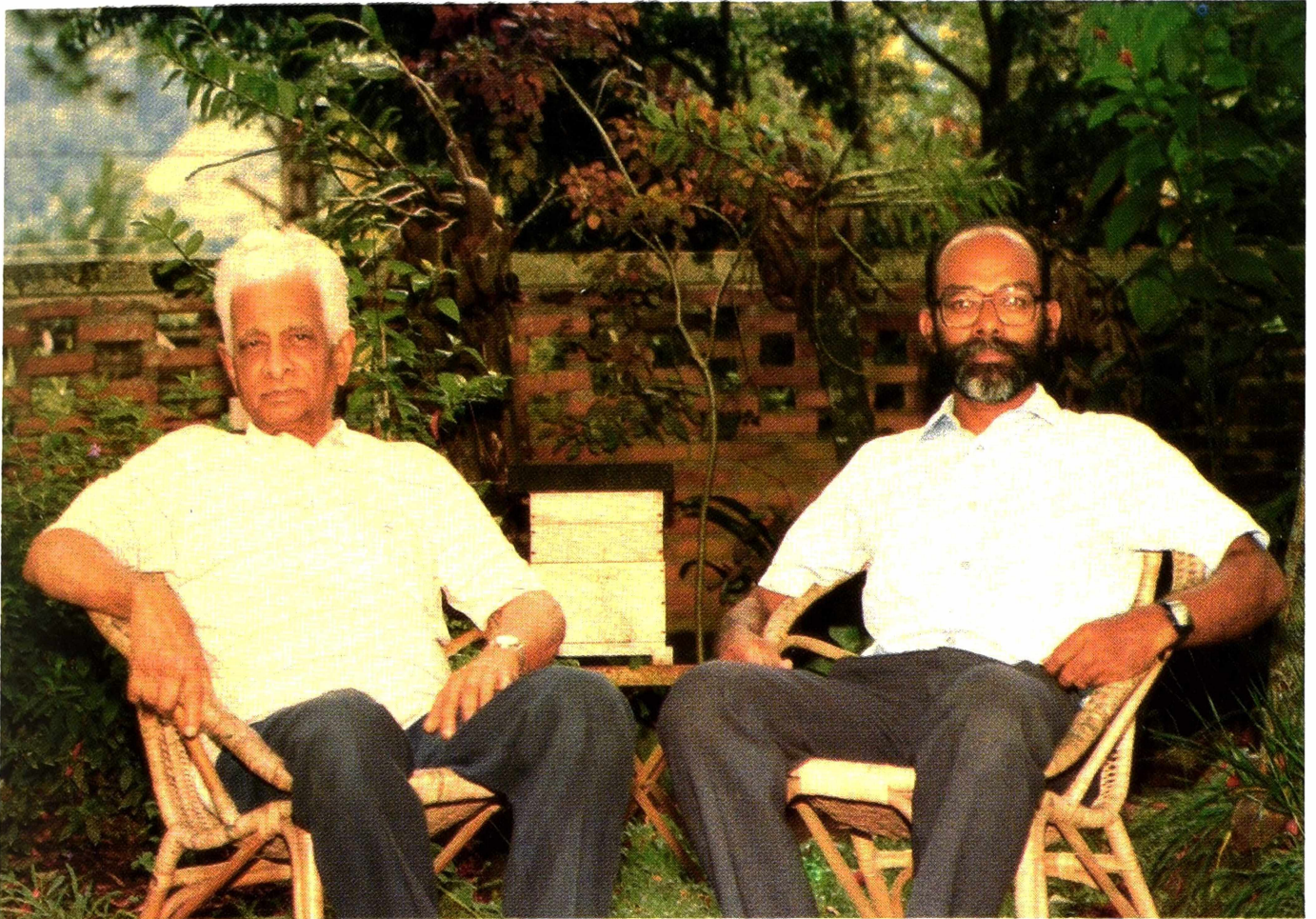

Ranjith Wasantha Kumara Punchihewa was introduced to the fascinating world of the Bees while studying Agricultural Entomology as an undergraduate at the Faculty of Agriculture, University of Peradeniya under his guru, Professor Bruce A. Baptist (left in photo), who later encouraged and directed him to undertake further studies on Bees. Consequently he conducted in-depth studies on flower-visiting insects and pollination ecology under Prof. Peter G. Kevan at the Department of Environmental Biology, University of Guelph, Ontario, Canada and then on the reproductive behaviour of the indigenous honeybee (Mee Bee) *Apis cerana* under Prof. Nikolaus Koeniger at the Bee Research Institute of the Zoological Institute, University of Frankfurt am Main, Germany. In 1980 he joined Sri Lanka Agricultural Service and engaged in scientific research related to the development of Beekeeping industry in Sri Lanka. During these efforts he spent much of his time in studying ways and means of effectively rearing and managing honeybees in agro-eco systems, the findings of which are presented through this book. Currently his emphasis is on the development of good quality productive strains of Mee Bees which are essential for the development of the industry in the island. For this purpose, he is utilizing the understanding that he gained from his experimentations on the natural reproductive behaviour, where a breeding process called "Controlled Natural Breeding Method" is synthesized and being tested. He also serves as a Visiting Lecturer in the Department of Agricultural Biology, Faculty of Agriculture, Peradeniya and the Chairperson of the Beekeeping Technology Section of the Asian Apicultural Association.

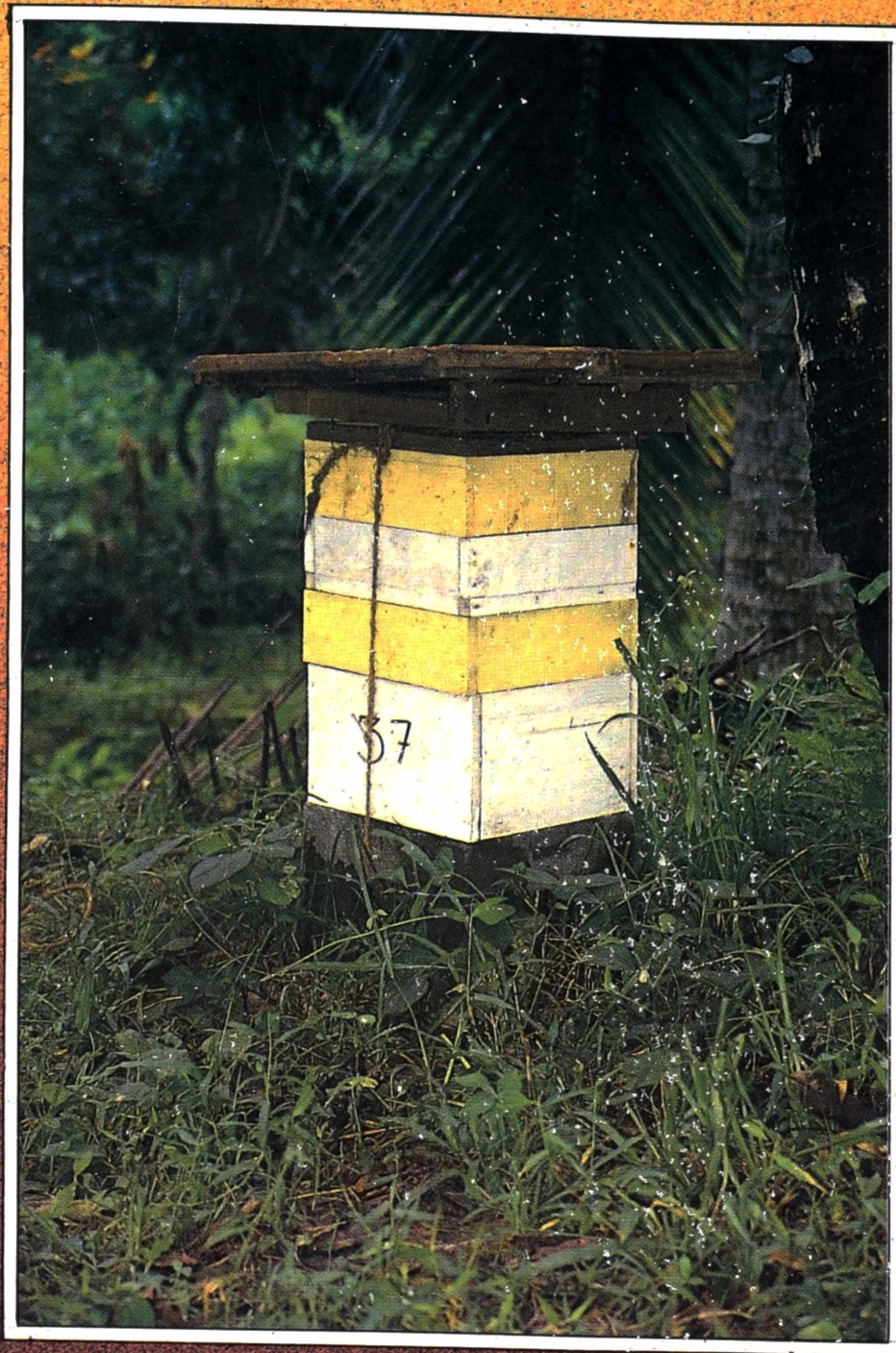

A Colony of Mee Bees Living in a Home Garden

The Bees render a yeoman service for the sustenance of the natural environment and of humankind as pollinators of flowering plants. Among Bees, the honeybees store honey in their nests and man has used this honey for his food from time immemorial. Among honeybees, the Mee Bee could be reared easily in human habitations and under conducive conditions they could be used to produce honey profitably. The Biological basis and its application in rearing the Mee Bees effectively is discussed in this book.

ISBN 955 - 9282 - 01 - 8

Printed at Sarvodaya Vishva Lekha, Rajmalana, Sri Lanka.

National Digitization Project
National Science Foundation

Institute : Department of Agriculture

1. Place of Scanning : Department of Agriculture, Peradeniya

2. Date Scanned : 2018 / 02 / 01

3. Name of Digitizing Company : Sanje (Private) Ltd, No 435/16, Kottawa Rd,
Hokandara North, Arangala, Hokandara

4. Scanning Officer

Name : N.S. Karunaratna

Signature : Sithara

Certification of Scanning

I hereby certify that the scanning of this document was carried out under my supervision, according to the norms and standards of digital scanning accurately, also keeping with the originality of the original document to be accepted in a court of law.

Certifying Officer

Designation : Chief Librarian

Name : Saumya Upamalika

Signature : Saumya

Date : 2018 / 02 / 01

"This document/publication was digitized under National Digitization Project of the National Science Foundation, Sri Lanka"